

T9000



Features

Common Features of the T9000 Products

- Fully functional keypad and display.
- Backlit Liquid Crystal display screen.
- Output pressure displays in psig, BAR, kPa, or user-defined pressure units.
- Independently adjustable PID tuning coefficients.
- Reverse acting capability for analog input and output signals.
- Select Current or Voltage mode for input signal or optional analog channels using the keypad.
- RFI/EMI protection eliminates electromagnetic and radio interference.

T9060



T9010



Operating Principles

The Model T9000 Series Pressure Controllers have a closed-loop, integrated, microprocessor control system that regulates outlet pressure. You can control the output from the Model T9000 products using the keypad or from an analog control signal. You can control the output from the Model T9000D using the keypad and through DeviceNet™ Communication network.

T9080

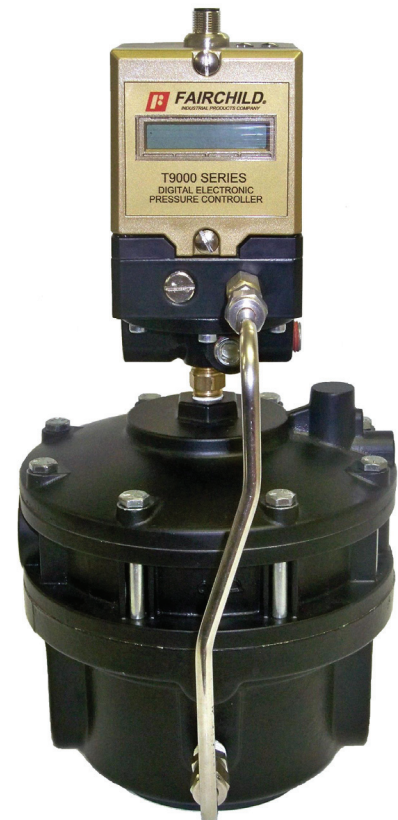

T9020



T9040



B

Model
T9000

Model T9000 Electro-Pneumatic Transducer

B
Model
T9000

T9000

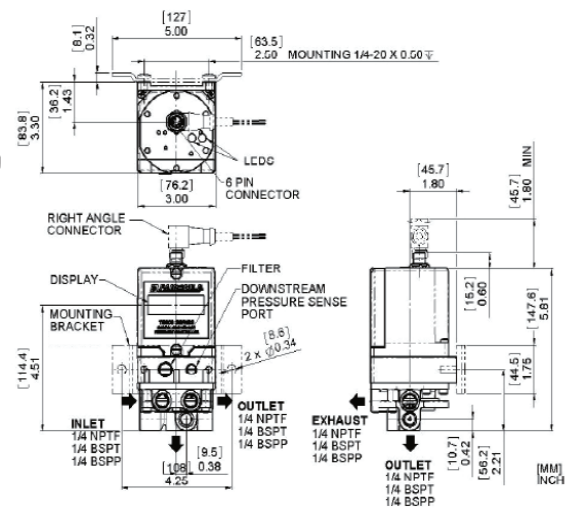

T9010

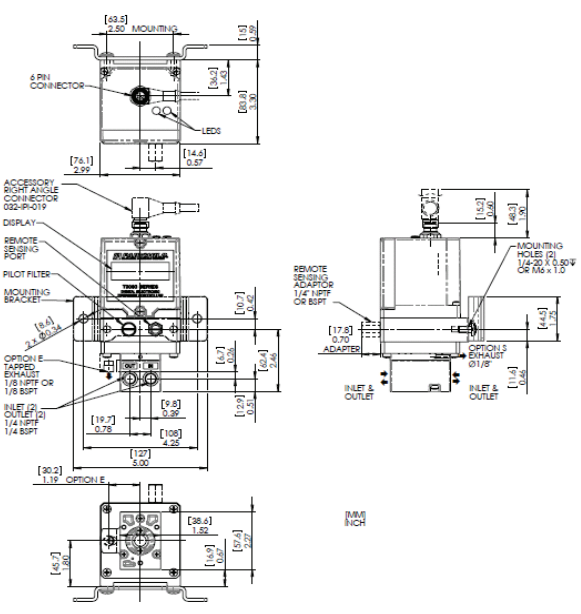

Flow Characteristics
Fairchild T9010-4012N Pressure Controller

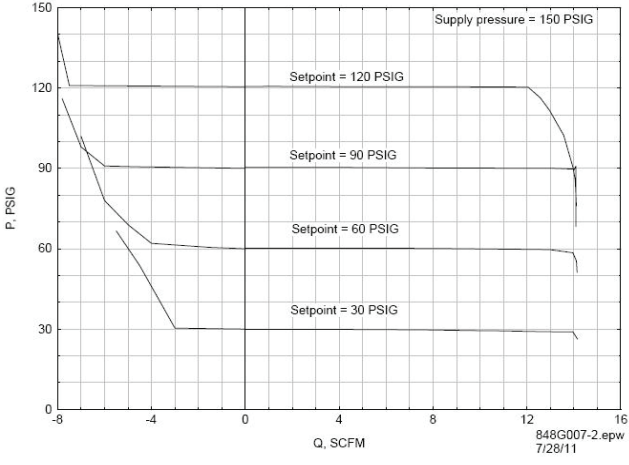

T9020

See T9000
For Top View

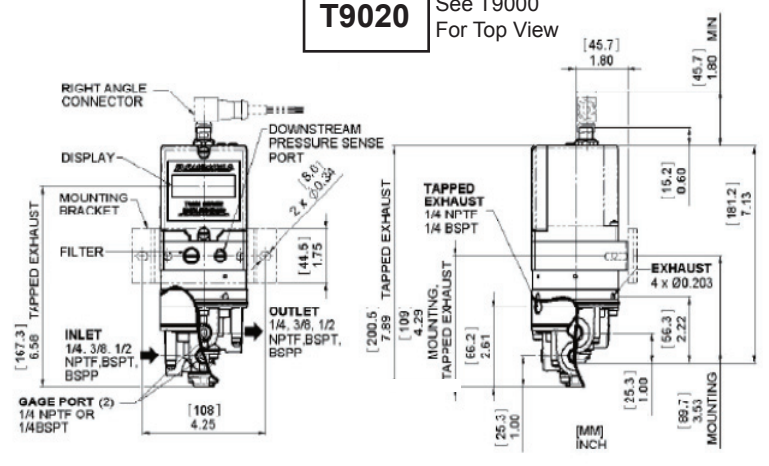

Flow Characteristics
T9020-4072N4NFS Pressure Controller

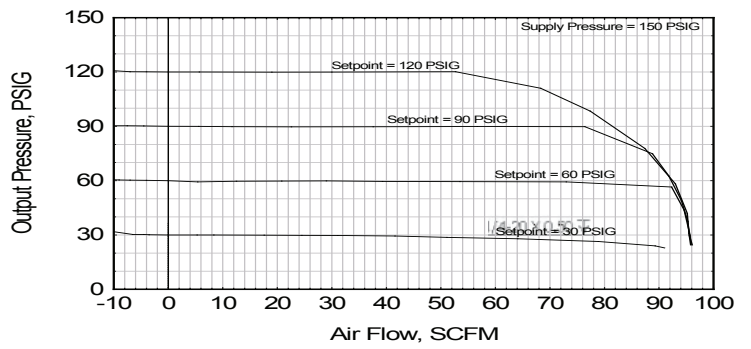

T9040

See T9000
For Top View

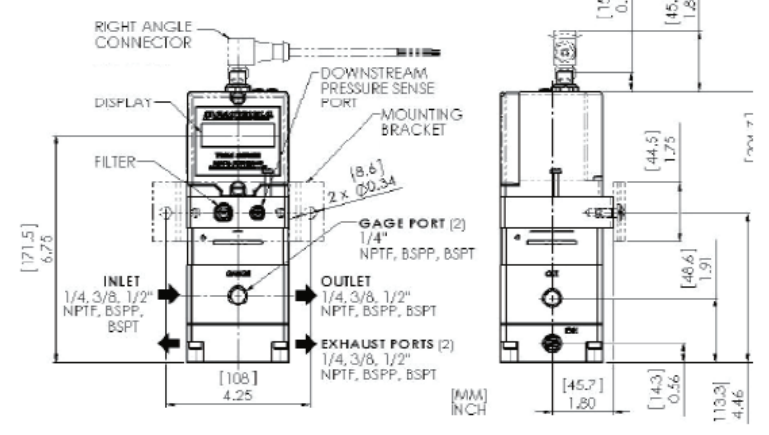

Flow Characteristics
T9040-4074N4FJT Pressure Controller

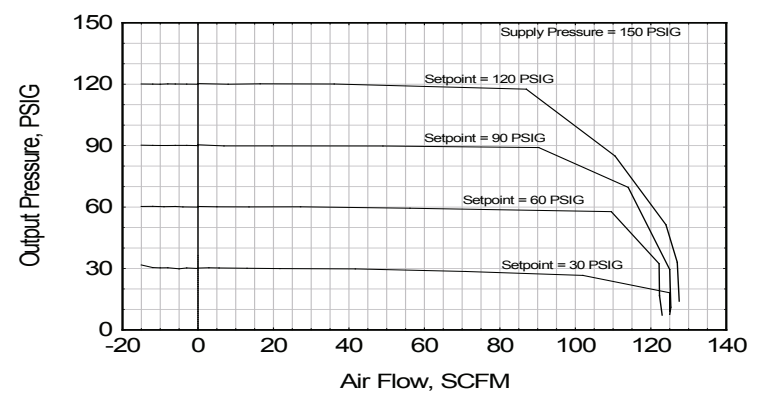

T9060

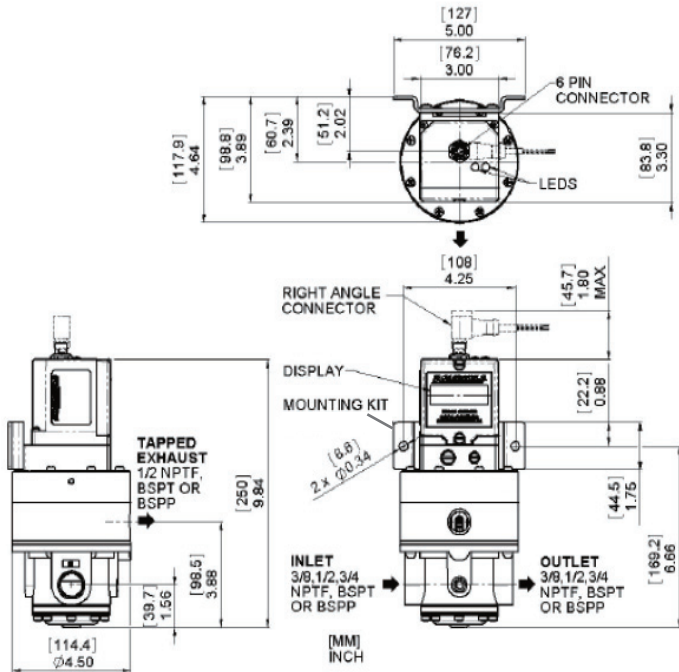

Flow Characteristics
T9060-4074N4FNT Pressure Controller

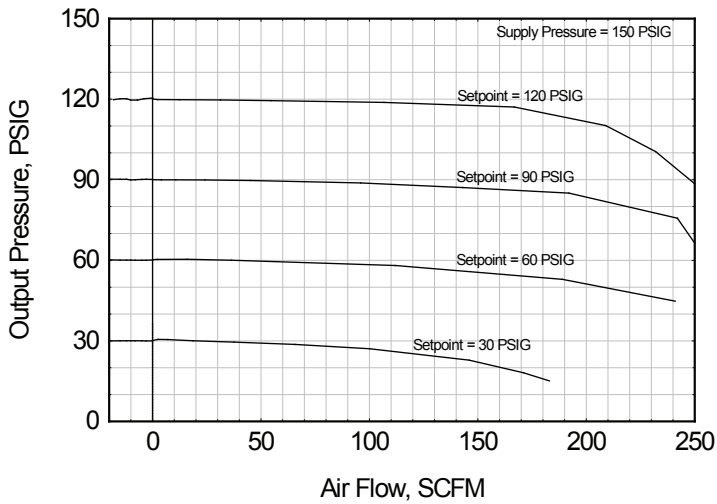

Flow Characteristics Chart

	Foward 150 psig [10 BAR] Supply	Exhaust 60 psig [4 BAR] Downstream Pressure
T9000	1 SCFM	-
T9010	12 SCFM	4 SCFM
T9020	90 SCFM	45 SCFM
T9040	110 SCFM	55 SCFM
T9060	220 SCFM	110 SCFM
T9080	700 SCFM	350 SCFM

T9080

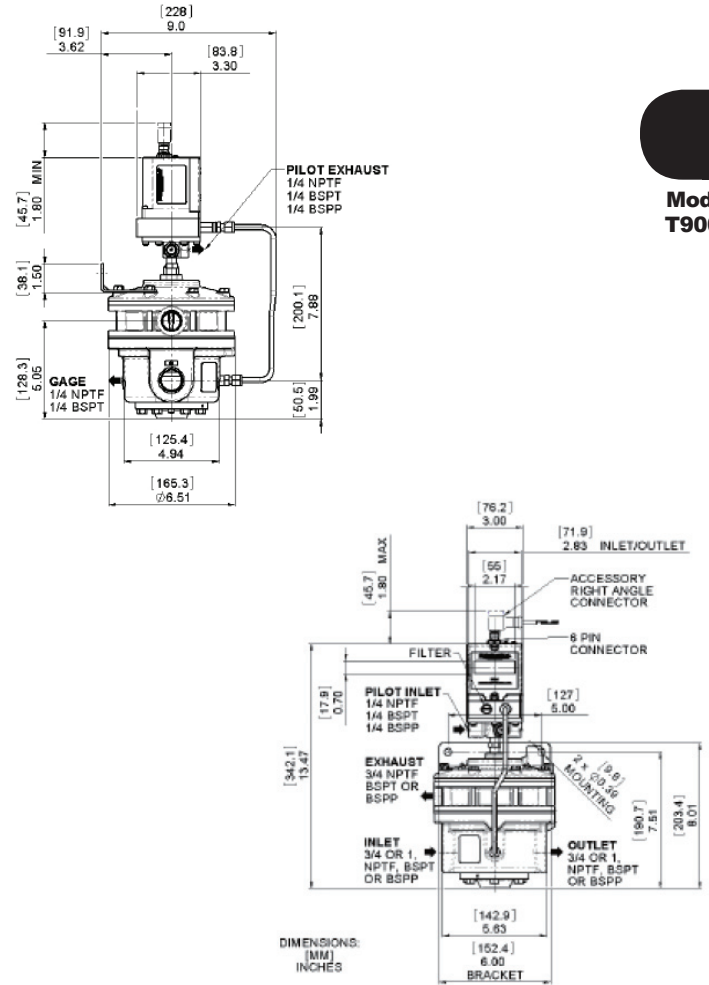

Flow Characteristics
T9080-4078N4FNT Pressure Controller

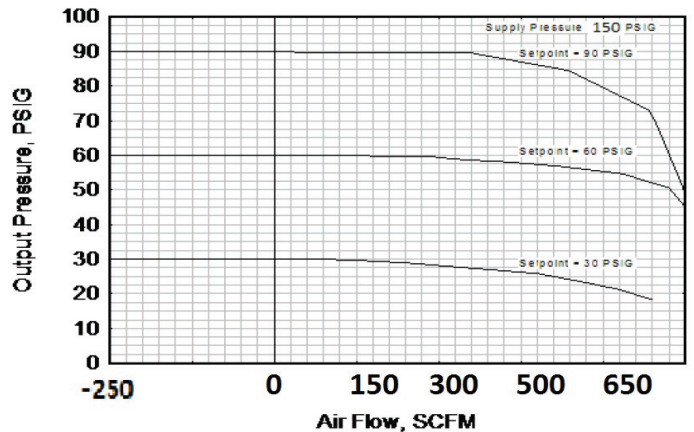

Model
T9000

Model T9000 Electro-Pneumatic Transducer

Specifications

Supply Pressure¹

200 psig, [14 BAR], (1400 kPa) Maximum

Pneumatic Outputs

psig:	0-30	0-75	0-150
[BAR]:	[0-2]	[0-5]	[0 - 10]
(kPa):	(0-200)	(0-500)	(0-1000)

Minimum Span

psig:	12	30	6	0
[BAR]:	[0.8]	[2.0]	[4 . 0]	
(kPa):	(80)	(200)	(400)	

Model T9000 Input Signal

4-20 mA, 0-10 VDC

Flow Rate 1-700 SCFM (Select desired configuration)

Exhaust Flow 1-350 SCFM (Select desired configuration)

Air Consumption

0 @ steady state output with Deadband @ 1 % of Full Scale

Supply Pressure Effect

No Measurable Effect

Electrical Supply

24 VDC ± 10 %

Power Consumption

Less than 5 watts

Analog Output Signal / Impedance

4-20 mA/500 ohms Maximum, 0-10 VDC/400 ohms Minimum

Deadband (ISA S51.1)

Adjustable from 0 to 10 % of Full Scale

Unit Accuracy (ISA S51.1)

Less than 0.50% Output Span

Frequency Response

-3 db @ 1 HZ per ISA S26.4.3.1 load Configuration A (typical but depends on specific T9000 product configuration)

Vibration Effect

Less than 1 % of Span under the following conditions: 5 - 15 Hz @ 0.8 inches constant displacement 15-500 Hz @ 10 g's

RFI/EMI Effect

Less than 0.5%. EMC Directive 89/336/EEC European Norms EN 50081-2 & EN 50082-2.

Temperature Range

0° F to + 160° F, (-18° C to + 71° C)

Materials of Construction

Body Housing.....Polymer, Chromate Treated Aluminum

Trim Zinc Plated Steel

Elastomers..... Nitrile, Fluorocarbon

Finish.....Epoxy

¹ Supply Pressure must be no less than 5 psig, [0.35 BAR], (35 kPa) above maximum output.

Unique Feature of the T9000D

- DeviceNet™ Communications connect the Model T9000D to a digital network to increase functional flexibility, installation speed, and reduce system wiring cost.

Available Options for the T9000 Series Transducer

- Optional analog output channel configured as an output pressure monitor or as a user-defined output.
- External Pneumatic Feedback port to sense down stream pressure. (See Cables and Accessories table)
- Optional Feedback Input Channel configurable to control setpoint, external process variable, or accept a user defined input. (Consult factory for availability.)

Catalog Information

Catalog Number T90

Flow Rate

1 SCFM (Basic Transducer)	00
12 SCFM	10
90 SCFM	20
110 SCFM	40
220 SCFM.....	60
700 SCFM	80

Input

0-10 VDC	0
4-20 mA	4
DeviceNet™	D

Output

0-30 psig	04
0-75 psig	05
0-150 psig	07
[0-2.0 BAR]	14
[0-5.0 BAR]	15
[0-10.0 BAR]	17
(0-200 kPa)	24
(0-500 kPa)	25
(0-1000 kPa)	27

Port Size

1/4" NPT (T9000,10,20,40 only)	02
3/8" NPT (T9020,40 only)	03
1/2" NPT (T9020,40 only)	04
3/4" NPT (T9060,80 only)	06
1" NPT (T9080 only)	08

Port Threads

NPTF Thread	N
BSPT Thread	U
BSPF Thread (Not Available on T9010)	H

Feedback Option

None	N
0-10 VDC Analog Output	0
4-20 MA Analog Output	4
0-10 VDC Feedback Input	5
4-20 MA Feedback Input	6

Elastomers

Nitrile (Not available in T9040)	N
Fluorocarbon	J

Power Failure Mode

Freeze (Maintains Setpoint)	F
-----------------------------------	---

Exhaust Port

Tapped	E
--------------	---

Remote Pressure Sensing Capability (see table below)

T9000 Cables and Accessories (sold separately)

Part Number	Description
032-IPI-018-2	Straight, Shielded 6 pin Female
032-IPI-019-2	Right angle, Shielded 6 pin Female
032-IPI-009-2F	Straight, Shielded Cable for DeviceNet™
032-IPI-009-2R	Right angle, Shielded Cable for DeviceNet™
21665-1N	1/8-27 NPTF Remote Pressure Sensor fitting
21665-1U	1/8-28 BSPT Remote Pressure Sensor fitting

Installation

For operating instructions, refer to the corresponding Fairchild *Operation and Maintenance Instructions*, OM-500T90FI, OM-500T90AB, OM-500T90AO, OM-500T90DB, OM-500T90DI, OM-500T90DO.

For installation instructions, refer to II-500T9000.