



Features

- Venturi aspiration compensates for downstream pressure losses
- Optional input and output biasing allows versatility in applications
- Adjustable from 30:1 dividing ratio to 1:30 multiplying ratio assures infinite pressure adjustments
- Floating seal ring isolates control chamber which increases stability by reducing effect of high flows.
- Panel or Line Mounting

Operating Principles

The Model 21 consists of a signal chamber lever arm, a Model 20 output valve body, and pivot assembly for lever arm adjustment. The ratio of output pressure to signal pressure is infinitely adjustable. The adjustment range permits signal amplification of 1:30 or signal reduction of 30:1 by rotation of the ratio adjustment knob.

The signal pressure acting on the signal chamber diaphragm transmits a force through a lever to the control diaphragm, thus setting output pressure. The lever fulcrum is adjustable.

Output pressure is a function of signal pressure times the ratio of lever arm lengths on either side of the fulcrum. A bias may be introduced by means of the set screws.

The Model 21D is available with both input and output adjustable bias. Maximum input bias is 3 psig, with a maximum output bias of 9 psig. The basic mathematical expression for the bias in this relay is:

$$P_o = (P_s - K_1) R + K_2, \text{ where}$$

P_o = Output pressure

P_s = Input signal

R = Ratio of setting

K_1 = Input bias, (-) only

K_2 = Output bias, (+) only

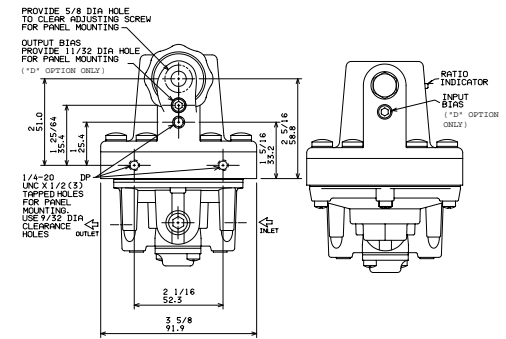
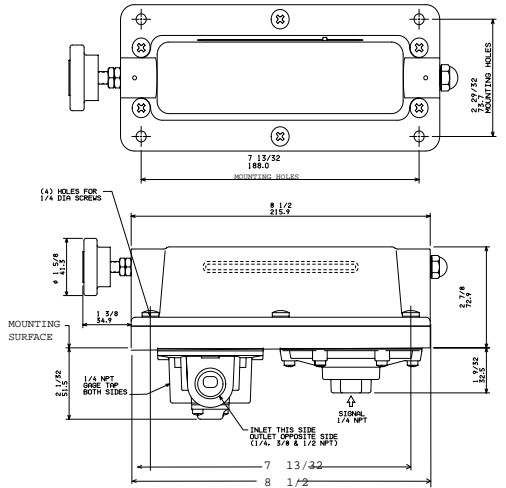
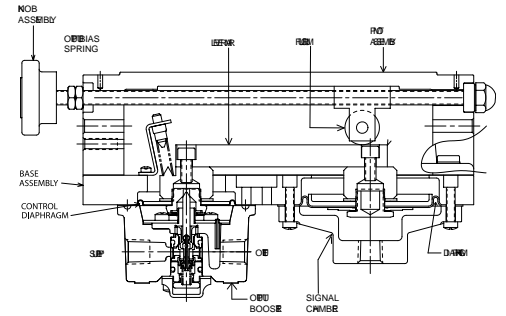

D
Model
21

Technical Information

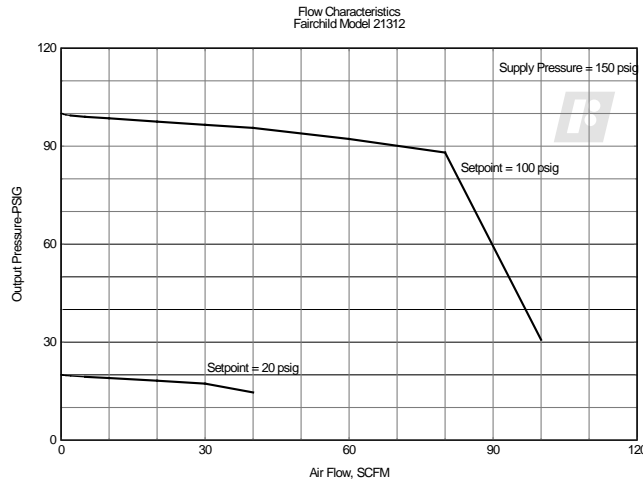

Specifications

Flow Capacity

40 SCFM (68 m³/HR) 100 psig, [7.0 BAR], (700 kPa) supply, 20 psig, [1.5 BAR], (150 kPa)

Exhaust Capacity

5.5 SCFM (9.4 m³/HR) (downstream pressure 5 psig, [.35 BAR], (35 kPa) above set pressure)

Supply Pressure

250 psig, [1.7 BAR], (1700 kPa) Maximum

Supply Pressure Effect

Less than .1 psig, [.007 BAR], (.7 kPa) for 100 psig, [7.0 BAR], (700 kPa) change

Signal or Output Pressure

150 psig, [1.0 BAR], (1000 kPa) Maximum

Ratio Range

30:1 through 1:30 (signal pressure: output pressure)

Operating Pressure (minimum)

0.5 psig, [0.03 BAR], (3.5 kPa)

Sensitivity

0.5" (1.27 cm) Water Column

Ambient Temperature Limits

-40°F to +200°F, (-40°C to +93.3°C)

Materials of Construction

Body and Housing.....Aluminum
 Trim.....Stainless Steel, Brass, and Zine Plated Steel
 Diaphragms.....Buna N and Dacron
 Lever and Fulcrum.....Hardened Steel

Catalog Information

Catalog Number 2 1 3 1

Pipe Size

1/4" NPT 2
 3/8" NPT 3

Options

Bias¹ D
 Fluorcarbon Elastomers J
 Tamper Proof T
 BSPT (Tapered) U

¹ Maximum Input Bias: -3 psig, [-0.2 BAR], (-20 kPa),
 Maximum Output Bias: 9.0 psig, [0.6 BAR], (60 kPa)

Installation

A service kit is available for the Model 21. Refer to the Fairchild Model 21 Relay Installation, Operation and Maintenance Instructions, IS-10000021.



Model 21