

Model T8000 Miniature Two Wire P/I Pressure Transducer

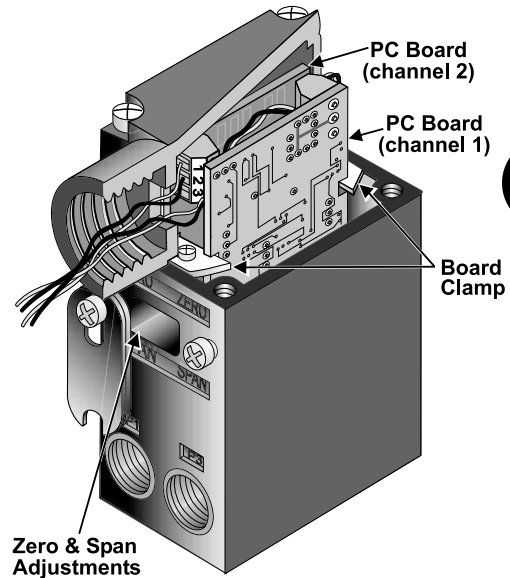

Features

- Field reversible feature provides output which is directly or inversely proportional to the input signal.
- RFI/EMI Protection eliminates susceptibility to electromagnetic and radio interference.
- Outputs of 4-20 mA or 10-50 mA cover standard loop outputs.
- Seven input signal ranges cover all standard inputs.
- Compact size permits use in space restricted areas.
- Explosion-Proof NEMA 4X, IP65, Type 4 Enclosure available for outdoor and indoor installations.
- Input and Output ports on both front and rear simplifies pneumatic piping.
- Conduit Fitting, Terminal strip or DIN connectors allow easy wiring to units
- Various mounting configurations allow installation flexibility for most applications.



B

Model T8000



The T8000 Series is designed for precision applications providing maximum versatility. The modular construction permits any basic unit to be used in the explosion-proof, rack, wall, pipe, panel, DIN rail or 3, 5, 10, or 15 unit manifold configurations. Servicing or calibration is quick and easy.

Operating Principles

Standard Range

The T8000 Series is a miniature two wire pressure device that converts a pneumatic input signal to a linearly proportional output current.

The PC Board Assembly contains a Piezoresistive Pressure Sensor, which is connected in a Wheatstone bridge configuration. The input air pressure on the Pressure Sensor induces a Piezoresistive change which causes a bridge unbalance. As a result, a differential signal is applied to the current source device which supplies the loop.

The Zero and Span adjustments are easily accessible from the front of the unit. The T8000 Series may be configured as a Single or Dual Channel Unit. The Dual Channel Unit consists of two PC Boards that are enclosed within the same housing and function independently of each other. This unit may be offered in any one of the seven standard input pressure signals or in any combination.

Explosion-Proof

The TX8000 Unit consists of a TT8000 Series Transducer enclosed in an explosion-proof/NEMA 4X (IP65) housing.

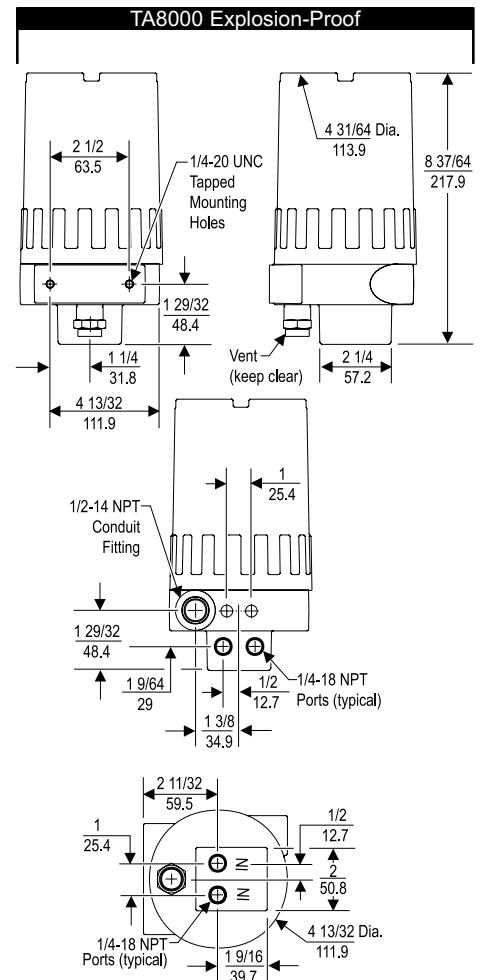

Model T8000 Miniature Two Wire P/I Pressure Transducer

B
Model
T8000

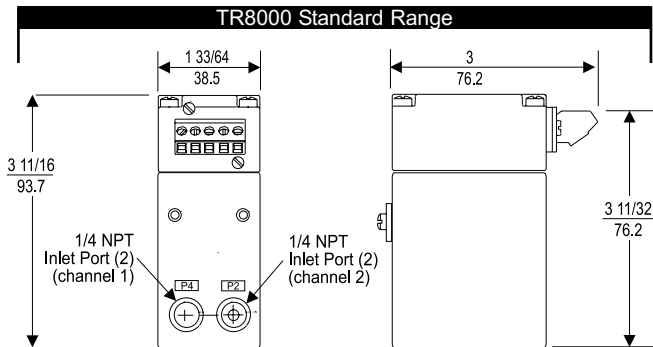
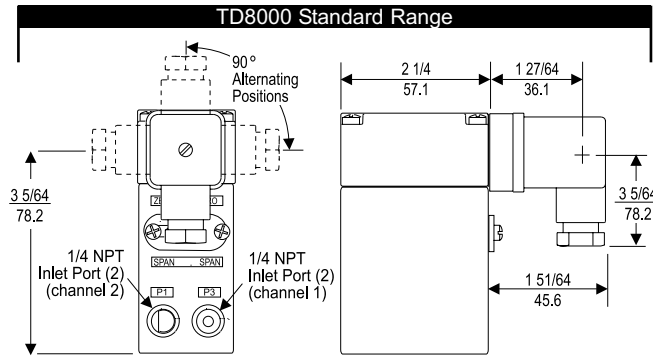
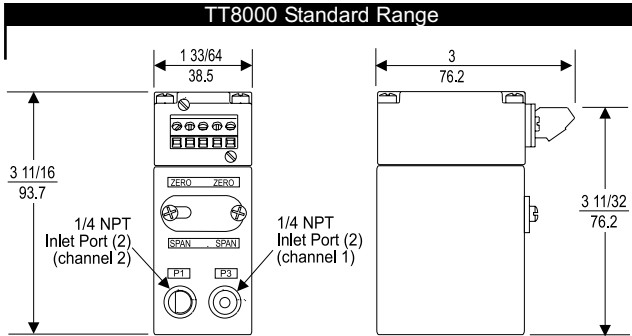
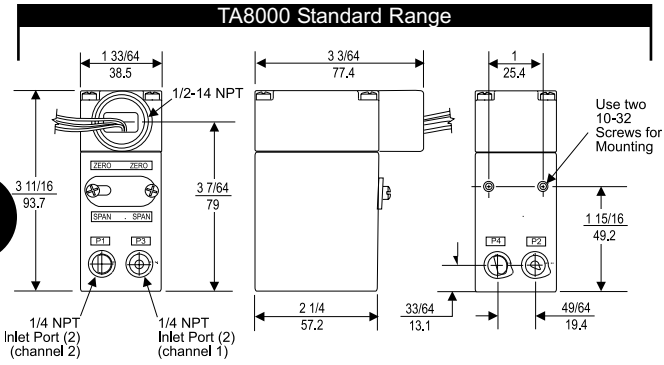

NOTE: Model TR8000 Transducer is designed for use with the TR Rack Kit. Physically, it is the same as the TT8000 Unit except that the terminal block has been rotated to the rear.

Specifications: T8000 Standard Range Transducers

	psig, [BAR], (kPa)						
Pneumatic Input Range	0-5 [0-0.3] (0-35)	3-15 [0.2-1.0] (20-100)	3-27 [0.2-1.8] (20-180)	6-30 [0.4-2.0] (40-200)	0-30 [0-2.0] (0-200)	0-60 [0-4.0] (0-400)	1-120 [0-8.0] (0-800)

Current Output 4-20 mA or 10-50 mA

Supply Voltage 12-50 VDC for 4-20 mA
12-30 VDC for 10-50 mA

Minimum Output Span	4 [0.28] (28)	12 [0.8] (80)	23 [1.45] (145)	23 [1.45] (145)	23 [1.45] (145)	38 [2.6] (260)	75 [5.0] (500)
Maximum Output Span	10 [0.7] (70)	30 [2.0] (200)	60 [4.0] (400)	60 [4.0] (400)	60 [4.0] (400)	100 [7.0] (700)	200 [14.0] (1400)

Independent Linearity
+0.15% Full Scale

Hysteresis & Repeatability
Less than 0.1% Full Scale

Resolution
Infinite

Environmental
Operating Temperature: -40°F to 176°F (-40°C to 80°C)
Humidity: 95 % Relative Humidity

Load - Maximum
1900 OHMS @ 20 mA
360 OHMS @ 50 mA

Stability
Compensated Range: 32°F to 122°F (0°C to 50°C)
Temperature Compensation:
Zero ±1% FS - 32°F to 122°F (0°C to 50°C)
Span ±.5% FS- 32°F to 122°F (0°C to 50°C)
Drift Less than .25% FS/30 Days

Electrical
Calibration:
Zero -66 to 125% Full Scale
Span -25 to 200%
Response time Output less than 10 m-seconds from 10 to 90% input

Reverse Polarity Protected:
Output Ripple Less than 5mV peak to peak
Damping 7 seconds 10% to 90% FS jumper selectable

Mechanical
Damage Pressure: 3 times rated input or 200 psig, [15 BAR], (1500 kPa) whichever is less. 20 psig, [1.5 BAR], (150 kPa) for 5 psig, [.35 BAR], (35 kPa) range.

Recalibration Pressure: 2 times rated input
Vibration: No effect 10-200 Hz@ 2-10 G_s



RFI/EMI Effect
Less than 0.1% of Span @ 10 V/m class 2 Band ABC (20-1000 mHz) per SAMA PMC 33.1 1978 and less than 0.5% of Span @ 10 V/m level 3, 27-500 mHz band per IEC Standard 801-3 1984 (wire in conduit). EMC Directive 89/336 EEC European Norms EN 50081-2 & EN 50082-2.

Materials of Construction

Body and Housing Aluminum
Trim Stainless Steel, Brass, Zinc Plated Steel
Wetted Materials Aluminum, Glass, Ceramic, Delrin, Nitrile, Silicone, RTV, Nickel
Material Compatibility Liquids and gases compatible with wetted materials

Model T8000 Miniature Two Wire P/I Pressure Transducer

Hazardous Area Classifications

	Explosion-Proof	Intrinsically Safe										
Factory Mutual (FM) Approvals 	Class I, Division 1, Groups B, C and D; Class II, Division 1, Groups E, F and G; NEMA 4X Enclosure.	TAFI8001, TFXI8001 Class I Division 1, Groups A, B, C, and D; Class II, Division 1, Groups E, F and G; Class III, Division 1; NEMA 4X Enclosure;										
	Non-Incendive	re Code T5.										
	TAFI8001 Class I, Division 2, Groups A, B, C and D; NEMA 4X Enclosure.	TDFI8001, TTFI8001, TRFI8001 Class I Division 1, Groups A, B, C, and D. Class II, Division 1, Groups E, F, and G. Class III, Division 1; Temperature Code T5.										
	TDFI8001, TTFI8001, TRFI8001 Class I, Division 2, Groups A, B, C, and D.	<table border="1"> <thead> <tr> <th colspan="2">Entity Parameters</th> </tr> </thead> <tbody> <tr> <td>$V_{max}^1 = 30$ VDC</td> <td>$C_i^3 = 0.0132$ μ F</td> </tr> <tr> <td>$I_{max}^2 = 100$ mA</td> <td>$L_i^4 = 0$ mH</td> </tr> <tr> <td>¹V_{max} = Max. Voltage</td> <td>³C_i = Capacitance</td> </tr> <tr> <td>²I_{max} = Max. Current</td> <td>⁴L_i = Inductance</td> </tr> </tbody> </table>	Entity Parameters		$V_{max}^1 = 30$ VDC	$C_i^3 = 0.0132$ μ F	$I_{max}^2 = 100$ mA	$L_i^4 = 0$ mH	¹ V_{max} = Max. Voltage	³ C_i = Capacitance	² I_{max} = Max. Current	⁴ L_i = Inductance
Entity Parameters												
$V_{max}^1 = 30$ VDC	$C_i^3 = 0.0132$ μ F											
$I_{max}^2 = 100$ mA	$L_i^4 = 0$ mH											
¹ V_{max} = Max. Voltage	³ C_i = Capacitance											
² I_{max} = Max. Current	⁴ L_i = Inductance											
Canadian Standards Association (CSA) Approvals 	Class I, Division 1, Groups B, C, and D; Class II, Division 1, Groups E, F, and G; Type 4 Enclosure; Rated 4-20 mA or 10-50 mA, 30 VDC Max. Maximum Ambient 65°C.	TACI8001, TCXI8001 Class I, Division 1, Groups A, B, C and D; Class II, Division 1, Groups E, F, and G; Type 4 Enclosure; Rated 4-20 mA, 30 VDC Maximum; Temperature Code T4.										
	Division 2											
	TACI8001 Class I, Division 2, Groups A, B, C, and D; Class II, Division 2, Groups E, F, and G; Type 4 Enclosure; Rated 4-20 mA, 30 VDC Max.; Temperature Code T3 C.	TDCI8001, TTCI8001, TRCI8001 Class I, Division 1, Groups A, B, C and D; Rated 4-20 mA, 30 VDC Maximum; Temperature Code T5.										
	TDCI8001, TTCI8001, TRCI8001 Class I, Division 2, Groups A, B, C and D; Rated 4-20 mA, 30 VDC Maximum; Temperature Code T3 C.	<table border="1"> <thead> <tr> <th colspan="2">Approvals are valid when connected through a Shunt Zener Diode Safety Barrier meeting the following parametric requirements:</th> </tr> </thead> <tbody> <tr> <td>System Type 1 and 4:</td> <td>Single Channel Polarized Rated: 28V Max. 300 Ohm Min.</td> </tr> <tr> <td>System Type 2 and 5:</td> <td>Dual Channel Polarized Rated 28V Max. 300 Ohm Min. & 28V Diode return per channel.</td> </tr> <tr> <td>System Type 3</td> <td>a. 28V Max. 300 Ohm Min. & 10V Max. 50 Ohm Min. return. b. 28.5V Max. 300 Ohm Min. & 9V Max. 50 Ohm Min. return. & 10V Max. 50 Ohm Min. return.</td> </tr> </tbody> </table>	Approvals are valid when connected through a Shunt Zener Diode Safety Barrier meeting the following parametric requirements:		System Type 1 and 4:	Single Channel Polarized Rated: 28V Max. 300 Ohm Min.	System Type 2 and 5:	Dual Channel Polarized Rated 28V Max. 300 Ohm Min. & 28V Diode return per channel.	System Type 3	a. 28V Max. 300 Ohm Min. & 10V Max. 50 Ohm Min. return. b. 28.5V Max. 300 Ohm Min. & 9V Max. 50 Ohm Min. return. & 10V Max. 50 Ohm Min. return.		
Approvals are valid when connected through a Shunt Zener Diode Safety Barrier meeting the following parametric requirements:												
System Type 1 and 4:	Single Channel Polarized Rated: 28V Max. 300 Ohm Min.											
System Type 2 and 5:	Dual Channel Polarized Rated 28V Max. 300 Ohm Min. & 28V Diode return per channel.											
System Type 3	a. 28V Max. 300 Ohm Min. & 10V Max. 50 Ohm Min. return. b. 28.5V Max. 300 Ohm Min. & 9V Max. 50 Ohm Min. return. & 10V Max. 50 Ohm Min. return.											



Model T8000 Miniature Two Wire P/I Pressure Transducer

Mounting Kits

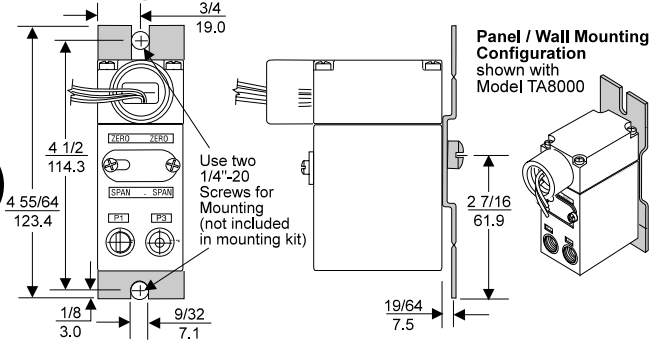

Mounting Bracket: 16799-1

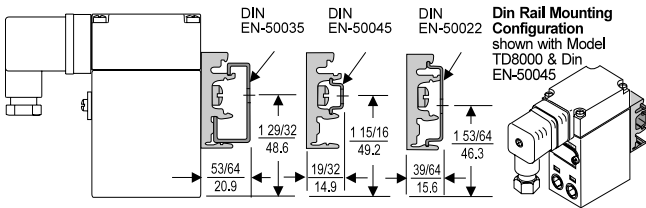

Mounting Bracket: 16893-1

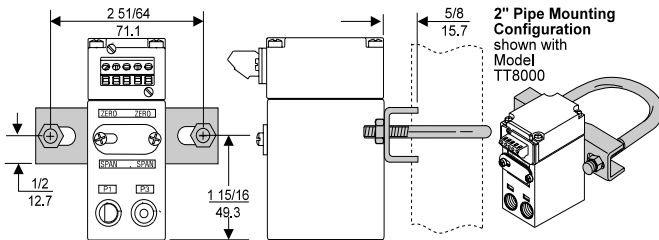

Mounting Bracket: 19254-1

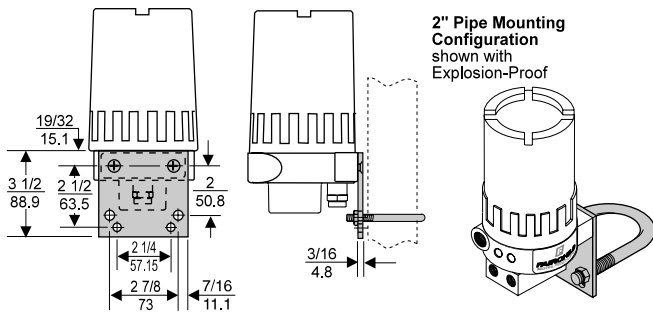

Mounting Bracket: 18187-1

Model T8000 Transducer Kits & Accessories

- Mounting Bracket Kits 16799-1 (included with unit)
 16893-1 (included with unit)
 19254-1 (sold separately)
 18187-1 (sold separately)

Catalog Information

Catalog Number T 8 0 0 1

Electrical Connections

- 1/2 NPT Conduit A
 Fitting with Pigtail
 DIN43650 Connection D
 Rack Mount R
 Terminal Block T
 (leave blank for Explosion-Proof)

Underwriting Group

- Canadian Standards C
 Factory Mutual F

Approval Class ¹

- Explosion-Proof X
 NEMA 4X (IP65)
 Intrinsically Safe ² I

Pneumatic Input Channel 1

(Select appropriate psig, [BAR], or (kPa) range.)

- 0-5 psig 00
 3-15 psig 01
 3-27 psig 02
 6-30 psig 03
 0-30 psig 04
 0-60 psig 05
 0-120 psig 06

 [0-0.35 BAR] 10
 [0.2-1.0 BAR] 11
 [0.2-1.8 BAR] 12
 [0.4-2.0 BAR] 13
 [0-2.0 BAR] 14
 [0-4.0 BAR] 15
 [0-8.0 BAR] 16

 (0-35 kPa) 20
 (20-100 kPa) 21
 (20-180 kPa) 22
 (40-200 kPa) 23
 (0-200 kPa) 24
 (0-400 kPa) 25
 (0-800 kPa) 26

Current Output Channel 1

- 4-20 mA 1
 10-50 mA 2

If Channel 2 Not Used 00

If Channel 2 is used, select appropriate psig, [BAR], or (kPa) range from Input Channel 1 above.

Current Output Channel 2

- 4-20 mA 1
 10-50 mA 2

Options

- BSPT Thread U

¹ Select Approval(s) Required.

² Includes Division 2 Approval.