

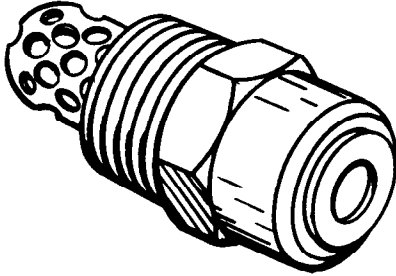

DIRECTIONAL SPRAY NOZZLES w/STRAINER, OPEN

TYPE HV (HIGH VELOCITY)



GENERAL DESCRIPTION

The Type HV High Velocity Nozzles are open (non-automatic) directional spray nozzles with individual inlet strainers (Ref. Figure A). They are designed for use in water spray fixed systems for fire protection applications where a high velocity water application may be required, such as for the protection of flammable liquids.

Available in either brass or stainless steel, the six patterns of the Type HV Nozzles provide a wide range of orifice sizes and distribution characteristics. As water passes through the internal swirl plate, a swirling action is produced, prior to the water being discharged through the orifice tip of the body, resulting in a solid conical spray pattern of water droplets being discharged over a defined area.

High velocity type nozzles are principally used in waterspray systems for the protection of fixed hazards such as transformers, circuit breakers, diesel engines and diesel storage tanks, turbo alternators, lube oil systems, oil fired boilers, and similar hazards. They are capable of rapidly extinguishing oil fires by emulsification, cooling, and smothering. The surface cooling effects of high velocity type nozzles also minimizes the possibility of reignition after a fire extinguishment.

APPROVALS AND STANDARDS

The brass and stainless steel Types HV-14 through HV-60 Nozzles are listed by Underwriters Laboratories,

DIMENSIONS IN INCHES AND (MM)					
TYPE	A	B	C	D	E-NPT*
HV-14	1.87 (47,1)	2.83 (71,9)	1.50 (38,1)	1.30 (33,0)	1
HV-17	1.87 (47,1)	2.83 (71,9)	1.50 (38,1)	1.30 (33,0)	1
HV-26	1.87 (47,1)	2.83 (71,9)	1.50 (38,1)	1.30 (33,0)	1
HV-37	2.03 (51,6)	3.00 (76,2)	1.50 (38,1)	1.30 (33,0)	1
HV-45	2.03 (51,6)	3.00 (76,2)	1.50 (38,1)	1.30 (33,0)	1
HV-60	3.41 (86,6)	4.56 (115,8)	1.90 (48,3)	1.65 (41,9)	1-1/4

* Pipe thread connections per ISO 7/1 can be provided on special request.

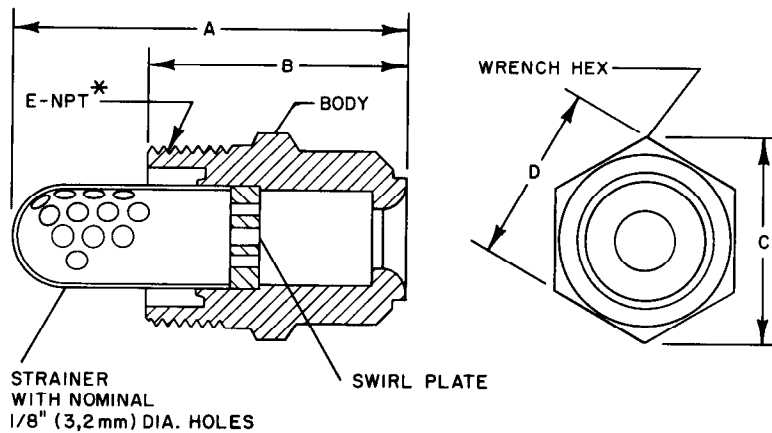

— TYPE HV-14, HV-17, AND HV-26 —

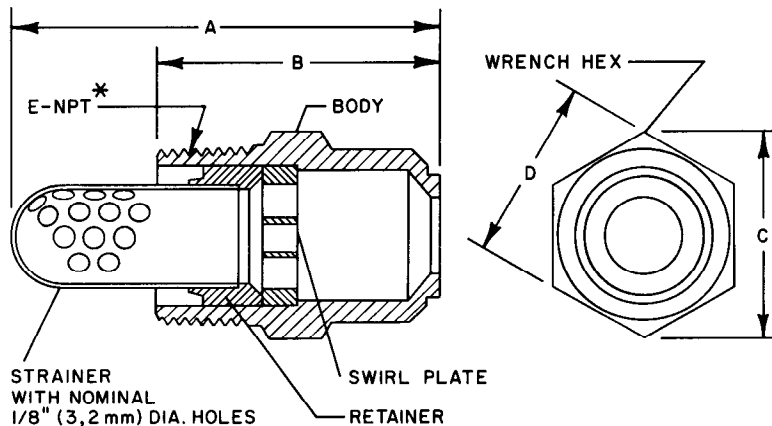

— TYPE HV-37, HV-45, AND HV-60 —

FIGURE A
TYPE HV HIGH VELOCITY NOZZLES

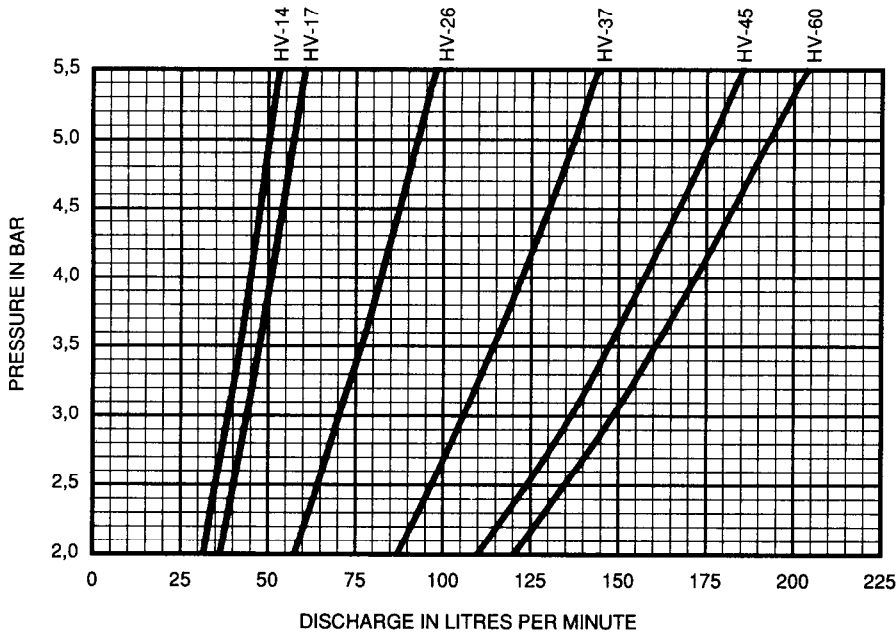

TYPE	Nominal K-Factors	
	NFPA (GPM + √psi)	ISO/SI (LPM + √bar)
HV-14	1.6	23,0
HV-17	1.8	26,0
HV-26	2.9	41,8
HV-37	4.3	62,0
HV-45	5.5	79,2
HV-60	6.0	86,4

1 bar = 100 kPa

NOTE: $Q = K\sqrt{p}$; where "Q" = flow in liters per minute, "p" = pressure in bar, and "K" is the nominal discharge coefficient.

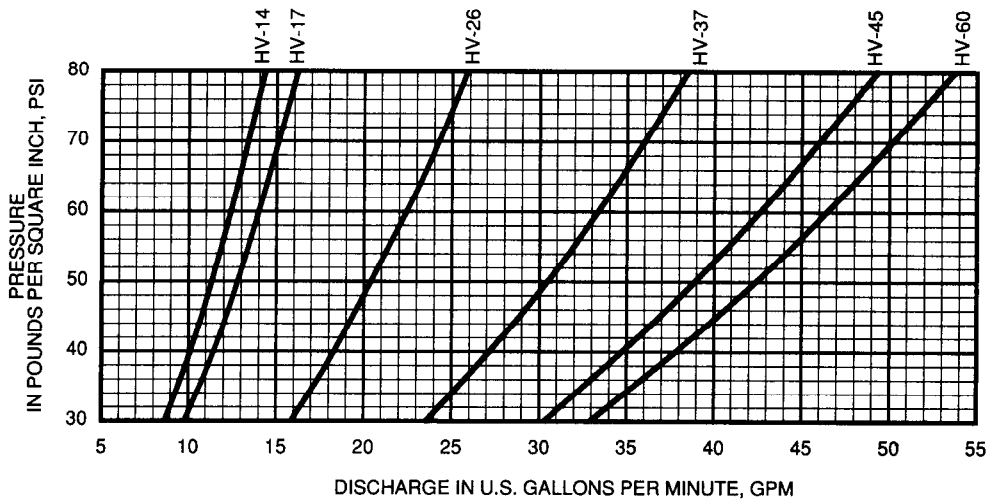

NOTE: $Q = K\sqrt{p}$; where "Q" = flow in U.S. gallons per minute, "p" = pressure in pounds per square inch, and "K" is the nominal discharge coefficient.

FIGURE B
NOMINAL DISCHARGE CURVES AND K-FACTORS
 (Refer to the authority having jurisdiction for their minimum required residual pressure.)

Inc. and Underwriters' Laboratories of Canada. They are approved by the Factory Mutual Research Corporation and the Scientific Services Laboratory.

WARNINGS

The Type HV Nozzles described herein must be installed and maintained in compliance with this document, as well as with the applicable standards of the National Fire Protection Asso-

ciation, in addition to the standards of any other authorities having jurisdiction. Failure to do so may impair the integrity of these devices.

The design of individual water spray fixed systems can vary considerably, depending on the characteristics and nature of the hazard, the basic purpose of the spraying system, the configuration of the hazard, and

wind/draft conditions. Because of these variations as well as the wide range of available nozzle spray characteristics, the design of water spray fixed systems for fire protection must only be performed by experienced designers who thoroughly understand the limitations as well as capabilities of such systems.

The owner is responsible for main-

NOTES:

1. Reference data applies to still air.
2. The Overall Spray Patterns in the plan view are the same as those shown in Figure C-1.

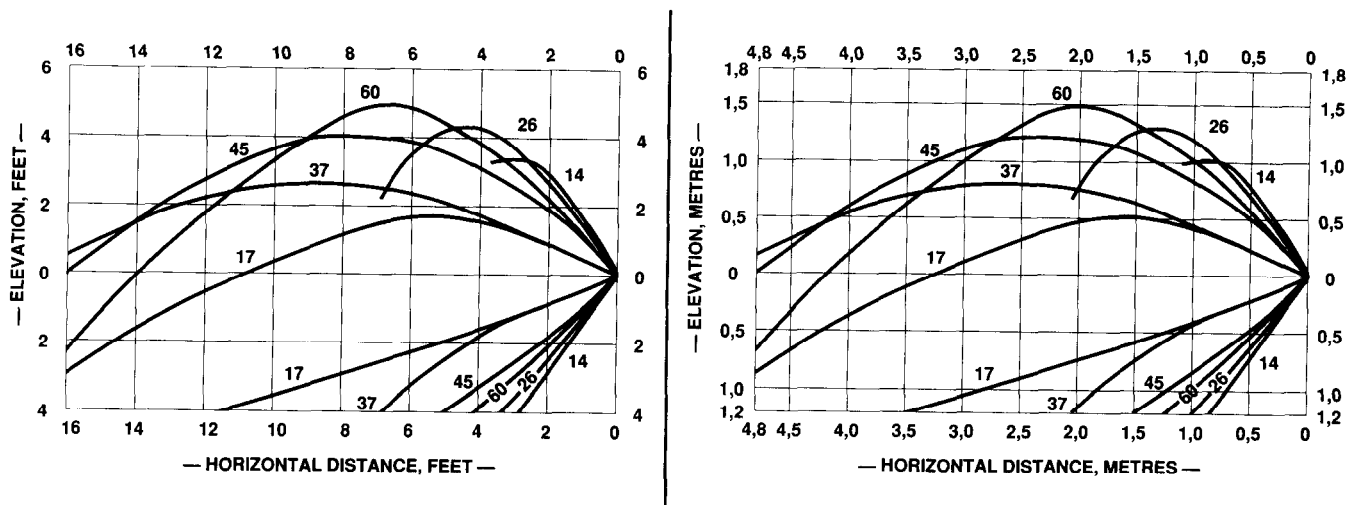

FIGURE D
REFERENCE GUIDE SHOWING THE OVERALL VERTICAL SPRAY PATTERNS
WHEN PROJECTING WATER HORIZONTALLY BEYOND THE DESIGN PARAMETERS GIVEN IN FIGURE C-2
— 30 to 80 PSI (2,1 to 5,5 bar) —

taining their fire protection system and devices in proper operating condition. The installing contractor or manufacturer should be contacted relative to any questions.

TECHNICAL DATA

The Type HV-14 through HV-60 Nozzles are rated for use at a maximum service pressure of 175 psi (12,1 bar). They are available in either brass or stainless steel, and the type designation (i.e., HV-14, HV-17, etc.) is stamped on the Body. The 1 inch NPT pipe thread connections for the HV-14 thru HV-45, as well as the 1-1/4 inch NPT connection for the HV-60, are threaded per ANSI Standard B1.20.1. Pipe thread connections per ISO 7/1 can be provided on special request.

NOTES

Refer to the Warning Section for an important notice concerning the design of individual water spray fixed systems.

Inquiries concerning nozzle installation and usage criteria, not covered by these instructions, should be mailed to the attention of the Technical Data Department. Include sketches and technical details, as appropriate.

Materials. The Body, Swirl Plate, and Retainer of the brass assemblies are brass per UNS C38510, and the

Strainer is copper per UNS C11000. The Body, Swirl Plate, and Retainer of the stainless steel assemblies are Type 316 stainless steel, and the Strainer is Type 316L stainless steel.

Discharge Capacity. The nominal discharge curves and K-factors for the six patterns of the Type HV Nozzles are given in Figure B.

Spray Patterns. The nominal overall spray patterns, spacing, and maximum recommended axial distances for the six patterns of the Type HV Nozzles are given in Figures C-1 and C-2 for residual (flowing) pressures of 30 psi (2,1 bar) to 80 psi (3,4 bar). A minimum residual pressure of 30 psi (2,1 bar) can typically be used for most applications; however, a minimum residual pressure of 50 psi (3,4 bar) is recommended for applications requiring high velocity water delivery, such as those specifying rapid extinguishment of oil fires by emulsification.

The maximum recommended axial distances given in Figure C-1 and C-2 are based on maintaining the specified spray patterns under a maximum wind condition of 15 MPH (24 km/h).

Figure D provides a reference guide showing the overall still air spray patterns beyond the maximum 15 MPH (24 km/h) axial distances, when the nozzles are projecting horizontally. As shown in Figure D, the spray patterns become non-concentric, beyond a certain point, due to the effects of gravity.

Main Pipeline Strainers. Even though individual strainers have been provided, main pipeline strainers are required for all systems utilizing Type HV Nozzles, since the waterways of the HV Nozzles are smaller than 3/8 inch (9,5mm) diameter. The individual strainers provided with the Type HV Nozzles are intended to meet the requirements of some authorities having jurisdiction which may specify the use of individual strainers in addition to main pipeline strainers.

INSTALLATION

The Type HV Nozzles must be installed by wrenching only on the hex portion of the Body.

CARE AND MAINTENANCE

Care must be exercised to avoid damage to the nozzles - both before and after installation. Nozzles damaged by dropping, striking, wrench twist/slip-page, or the like, must be replaced.

Water spray fixed systems for fire protection service require regularly scheduled care and maintenance by trained personnel. It is recommended that the HV Nozzles be periodically inspected for loading/obstructions, or other evidence of impaired protection. The inspections should be scheduled weekly or as frequently as may be nec-

NOTES (Figures C-1 and C-2):

1. Design data applies to a maximum wind condition of 15 MPH.
2. Unless otherwise noted, design data applies to a residual (flowing) pressure range at the nozzle inlet of 30 to 80 psi (2,1 to 5,5 bar). For pressures up to 175 psi (12.1 bar) consult the Technical Data Department.

Refer to the authority having jurisdiction for their minimum required residual pressure.
3. The shapes of the Overall Spray Patterns and Design Spray Profiles remain essentially unchanged over the Maximum Recommended Axial Distances.
4. See Technical Data Sheet TD680T for Drawing Templates of the Design Spray Profiles.

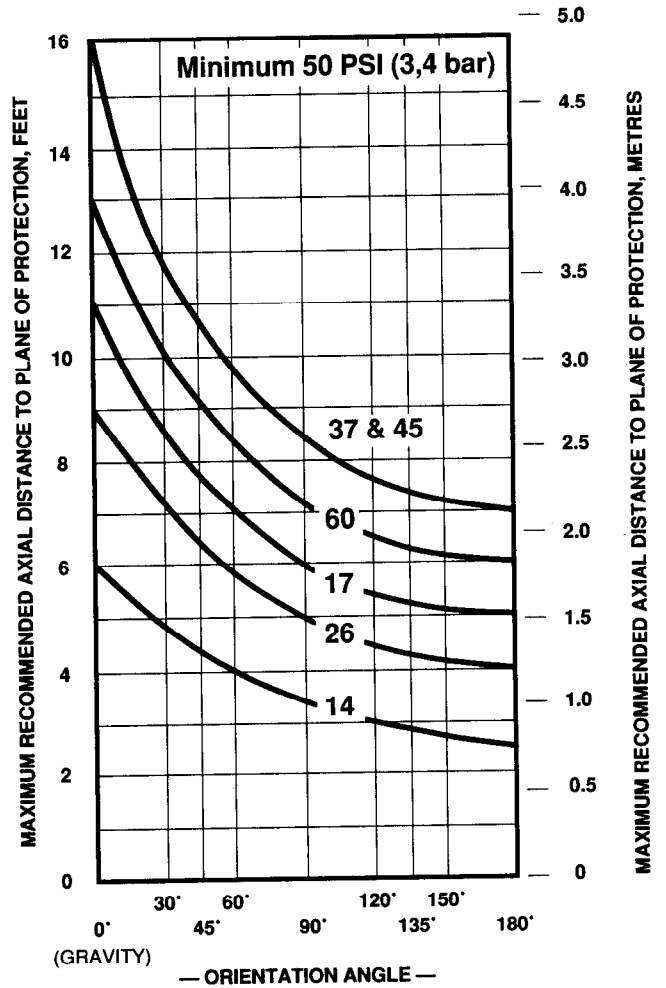
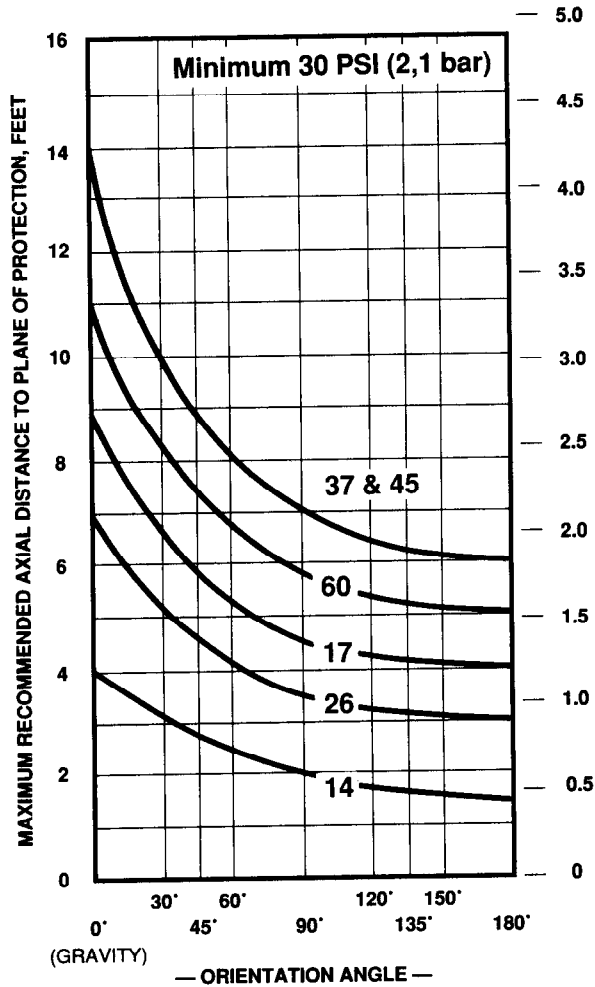
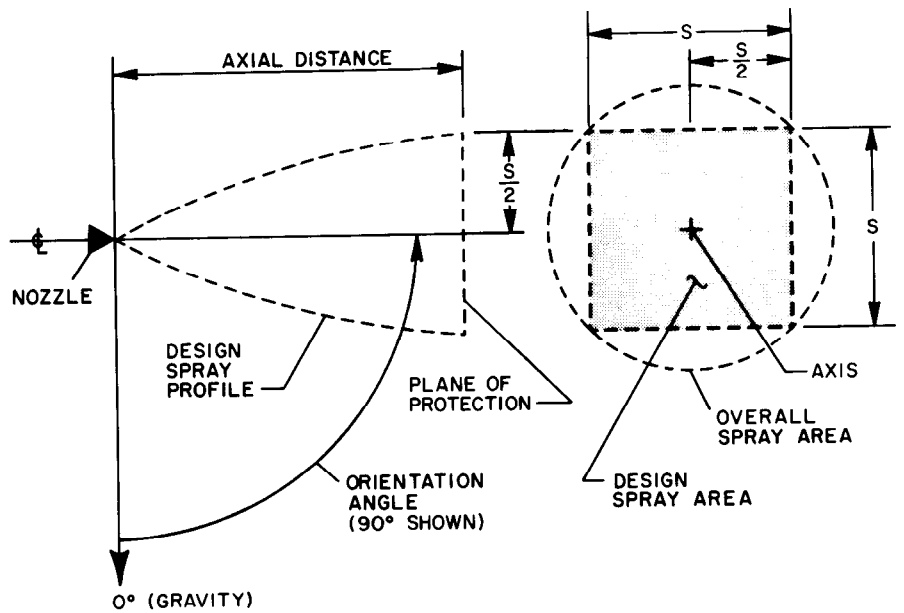

FIGURE C-2
— WATER DISTRIBUTION DESIGN DATA —
MAXIMUM RECOMMENDED AXIAL DISTANCE TO PLANE OF PROTECTION

essary and, corrective action taken to ensure that the nozzles will perform as intended in the event of a fire.

NOTE

Before closing a fire protection system main control valve for maintenance work on the fire protection system which it controls, permission to shut down the affected fire protection system must be obtained from the proper authorities and all personnel who may be affected by this action must be notified.

It is recommended that water spray fixed systems for fire protection be inspected by a qualified Inspection Service.

WARRANTY

Seller warrants for a period of one year from the date of shipment (warranty period) that the products furnished hereunder will be free from defects in material and workmanship.

For further details on Warranty, see Price List.

ORDERING PROCEDURE

Orders for Type HV Nozzles must include the description and Product Symbol Number (PSN), where applicable. Product Symbol Numbers are not specified when ordering special order Type HV Nozzles with thread connections per ISO 7/1.

Contact your local distributor for availability.

"Standard Order" HV Nozzles w/ NPT Thread Connections:

Specify: Type (specify number), (specify brass or stainless steel) Nozzles, PSN (specify).

Brass Assemblies

HV-14	PSN 49-014-1-001
HV-17	PSN 49-017-1-001
HV-26	PSN 49-026-1-001
HV-37	PSN 49-037-1-001
HV-45	PSN 49-045-1-001
HV-60	PSN 49-060-1-001

Stainless Steel Assemblies

HV-14	PSN 49-014-0-001
HV-17	PSN 49-017-0-001
HV-26	PSN 49-026-0-001
HV-37	PSN 49-037-0-001
HV-45	PSN 49-045-0-001
HV-60	PSN 49-060-0-001

"Special Order" HV Nozzles w/ Iso 7/1 Thread Connections :

Specify: Type (specify number), (specify brass or stainless steel) Nozzles with thread connection per ISO 7/1.