



Model CV-1FR Grooved-End Riser Check Valves 2 Inch to 12 Inch (DN50 to DN300)

General Description

The TYCO Model CV-1FR Grooved-End Riser Check Valve is a compact and rugged swing-type unit that allows water flow in one direction and prevents flow in the opposite direction. A resilient elastomer seal facing on the spring-loaded clapper ensures a leak-tight seal and non-sticking operation. The Model CV-1FR Riser Check Valves are designed to minimize water hammer caused by flow reversal.

The Model CV-1FR Riser Check Valve is furnished with grooved ends and can be installed using GRINNELL Grooved Couplings or GRINNELL Figure 71 Flange Adapters. The Model CV-1FR Riser Check Valves have been designed with a removable cover for ease of field maintenance. These valves can be installed horizontally (with cover in the upward position) or vertically with the flow in the upward direction. Refer to Figure 6.

To facilitate their use in wet-type automatic sprinkler system risers, the Model CV-1FR Riser Check Valves are provided with threaded outlets for pressure gauges and a drain connection. They provide a more compact and economical alternative to an alarm check valve where a water motor alarm is not required. Provisions must be made for a local alarm using an approved flow switch (not included).

The Model CV-1FR Riser Check Valve is also Listed for use in conjunction with the TYCO DV-5 Deluge Valve in Preaction Systems under air pressure without the use of prime water.

The Model CV-1FR Riser Check Valves are a redesign for the Central Figure 590FR and GRINNELL Figure 590FR.

NOTICE

The Model CV-1FR Riser Check Valve described herein must be installed and maintained in compliance with this document and with the applicable standards of the NATIONAL FIRE PROTECTION ASSOCIATION, in addition to the standards of any authorities having jurisdiction. Failure to do so may impair the performance of this device.

Never remove any piping component nor correct or modify any piping deficiencies without first de-pressurizing and draining the system. Failure to do so may result in serious personal injury, property damage, and/or impaired device performance.

The owner is responsible for maintaining their fire protection system and devices in proper operating condition. Contact the installing contractor or manufacturer with any questions.

Technical Data

Approvals

UL, C-UL Listed
FM Approved

Sizes

2 in. to 12 in. (DN50 to DN300)

Maximum Working Pressure

300 psi (20,7 bar)

Valve Assembly Finish

Red, non-lead paint



Installation

The Model CV-1FR Riser Check Valves are to be installed in accordance with this section:

1. The arrow cast on the Body must point in the direction of the flow.
2. Valves installed vertically must be positioned with the flow in the upward direction.
3. Valves installed horizontally must be positioned with the Cover facing up. Refer to Figure 6.
4. Grooved-end pipe couplings used with the Model CV-1FR Riser Check Valve must be installed in accordance with manufacturer's instructions.

NOTE: Valves should be installed a reasonable distance downstream from pumps, elbows, expanders, reducers, or other similar devices to extend the valve life. Standard piping practices call for a minimum of five times the pipe diameter for general use.

IMPORTANT

Refer to Technical Data Sheet TFP2300 for warnings pertaining to regulatory and health information.

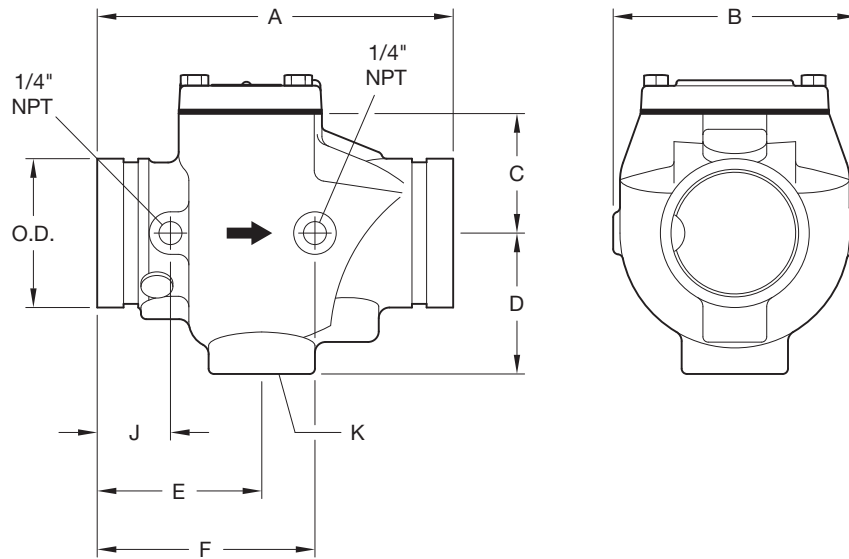

Nominal Pipe Size		Nominal Dimensions Inches (mm)								Cover Bolt Torque ft-lb (Nm)	Approx. Weight lb (kg)
ANSI Inches DN	O.D. Inches (mm)	A	B	C	D	E	F	J	K Inches NPT		
2 DN50	2.375 (60,3)	6.75 (171,5)	4.38 (111,3)	1.96 (49,8)	2.57 (65,3)	3.25 (82,3)	4.37 (111,0)	1.56 (39,6)	1	18 (25)	9.0 (4,5)
2-1/2 DN65	2.875 (73,0)	8.00 (203,2)	5.38 (136,7)	2.63 (66,8)	3.09 (78,5)	3.87 (98,3)	5.12 (130,0)	1.73 (43,9)	1-1/4	39 (54)	10.0 (4,5)
76,1 DN65	- (76,1)	8.00 (203,2)	5.38 (136,7)	2.63 (66,8)	3.09 (78,5)	3.87 (98,3)	5.12 (130,0)	1.72 (43,7)	1-1/4	39 (54)	10.0 (4,5)
3 DN80	3.500 (88,9)	8.37 (212,6)	5.72 (145,3)	2.81 (71,4)	3.31 (84,1)	3.87 (98,3)	5.12 (130,0)	1.72 (43,7)	1-1/4	39 (54)	11.0 (5,0)
4 DN100	4.500 (114,3)	9.63 (245,6)	6.68 (169,7)	3.80 (96,5)	3.63 (92,2)	4.53 (115,4)	5.78 (146,8)	2.12 (53,8)	2	50 (69)	25.0 (11,3)
139.7 DN125	- (139,7)	10.50 (266,7)	7.40 (188,0)	4.46 (113,2)	4.13 (104,9)	4.90 (124,5)	7.00 (177,8)	2.09 (53,1)	2	39 (54)	29.0 (13,2)
5 DN125	5.563 (141,3)	10.50 (266,7)	7.40 (188,0)	4.46 (113,2)	4.13 (104,9)	4.90 (124,5)	7.00 (177,8)	2.09 (53,1)	2	39 (54)	29.0 (13,2)
165.1 DN150	- (165,1)	11.50 (292,1)	8.00 (203,2)	4.62 (117,4)	4.50 (114,3)	5.00 (127,0)	7.25 (184,2)	2.00 (50,8)	2	60 (82)	47.0 (21,3)
6 DN150	6.625 (168,3)	11.50 (292,1)	8.00 (203,2)	4.62 (117,4)	4.50 (114,3)	5.00 (127,0)	7.25 (184,2)	2.00 (50,8)	2	60 (82)	47.0 (21,3)
8 DN200	8.625 (219,1)	14.00 (355,6)	10.14 (257,6)	6.67 (169,4)	5.52 (140,2)	5.46 (138,7)	10.50 (266,7)	2.43 (61,7)	2	120 (164)	66.0 (30,0)
10 DN250	10.750 (273,1)	18.00 (457,2)	12.38 (314,5)	8.62 (218,9)	6.41 (162,8)	7.50 (190,5)	10.75 (273,1)	3.38 (85,9)	2	130 (178)	109.7 (49,4)
12 DN300	12.750 (323,9)	21.0 (533,4)	14.28 (362,7)	9.93 (252,2)	7.27 (184,7)	7.62 (193,5)	10.00 (254,0)	3.13 (79,5)	2	130 (178)	151.0 (68,0)

FIGURE 1
MODEL CV-1FR RISER CHECK VALVES
NOMINAL DIMENSIONS

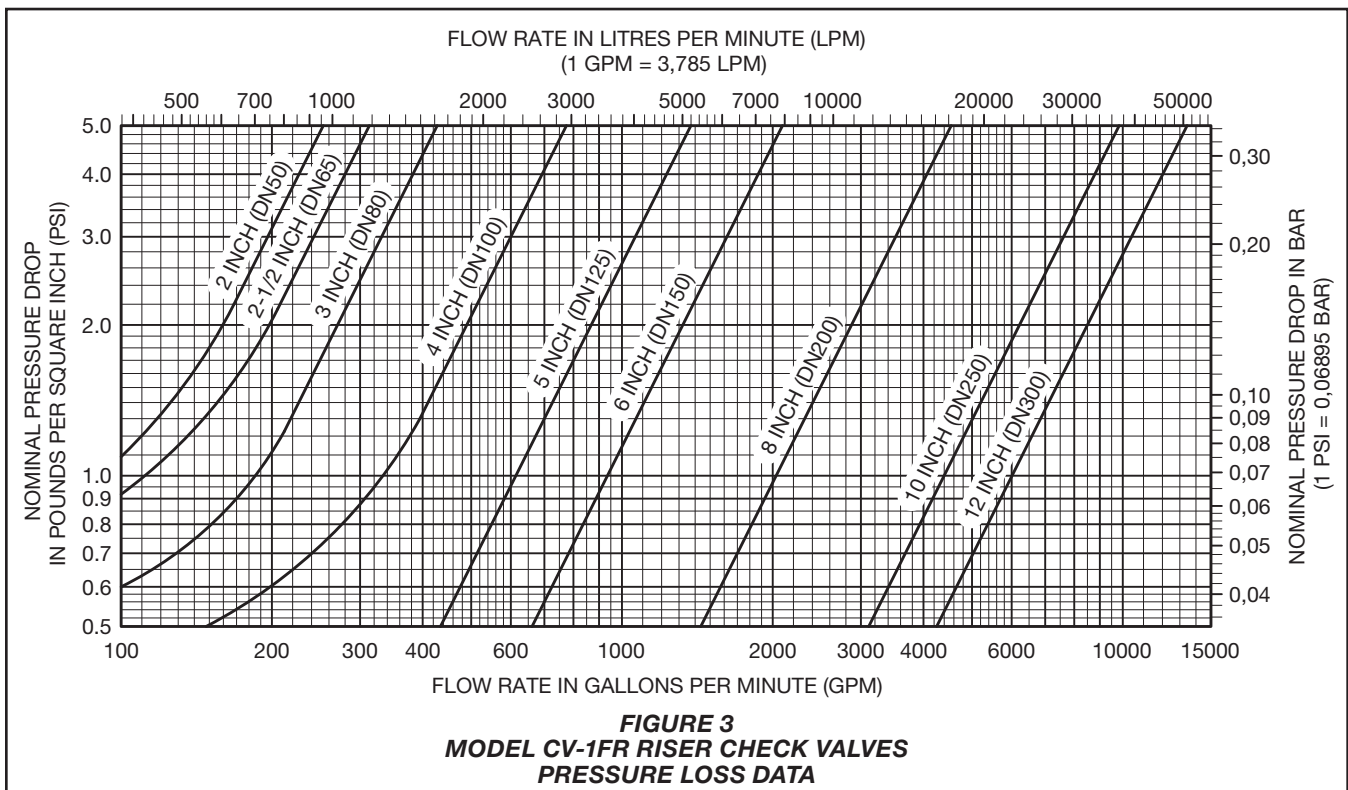
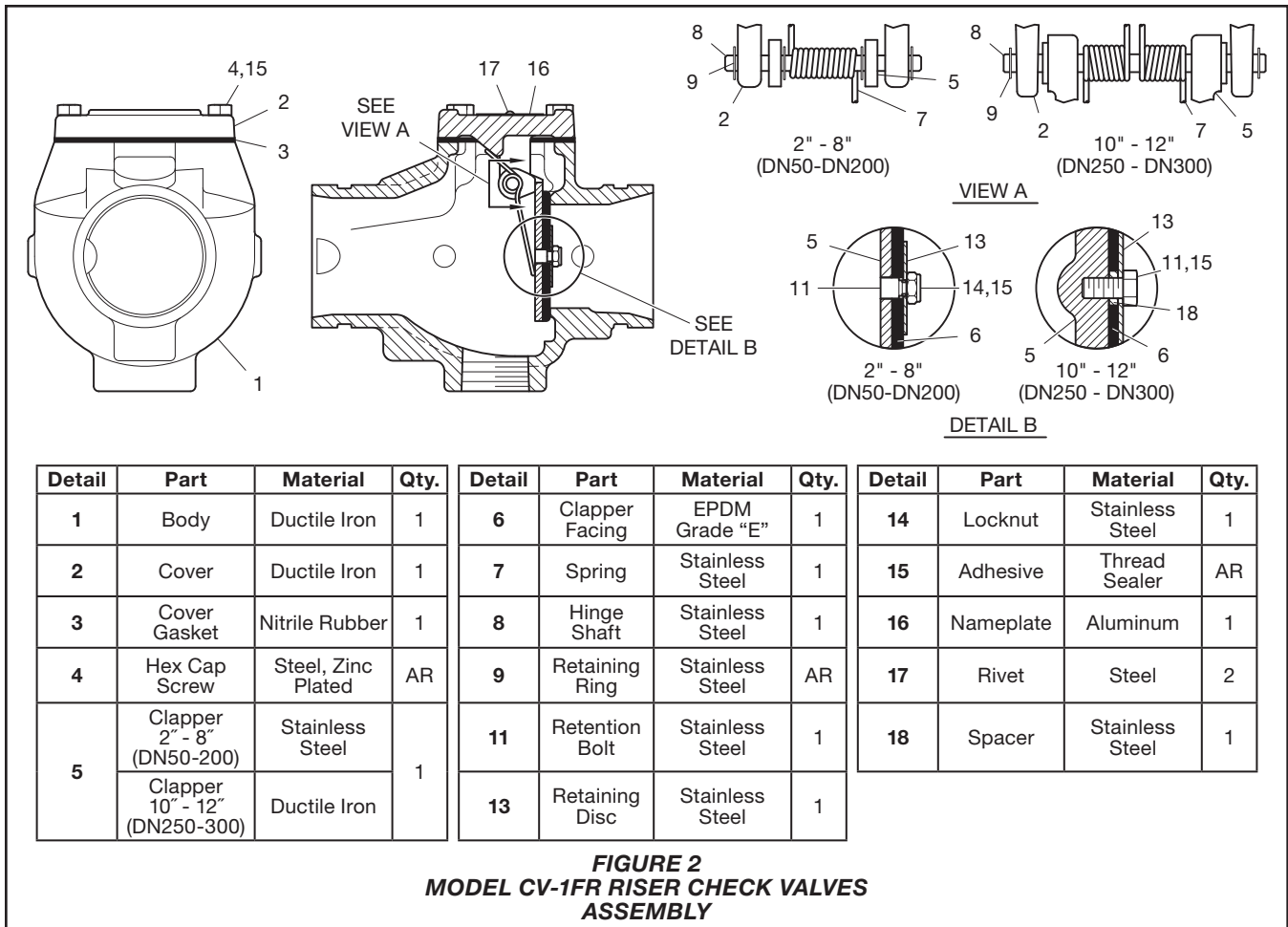

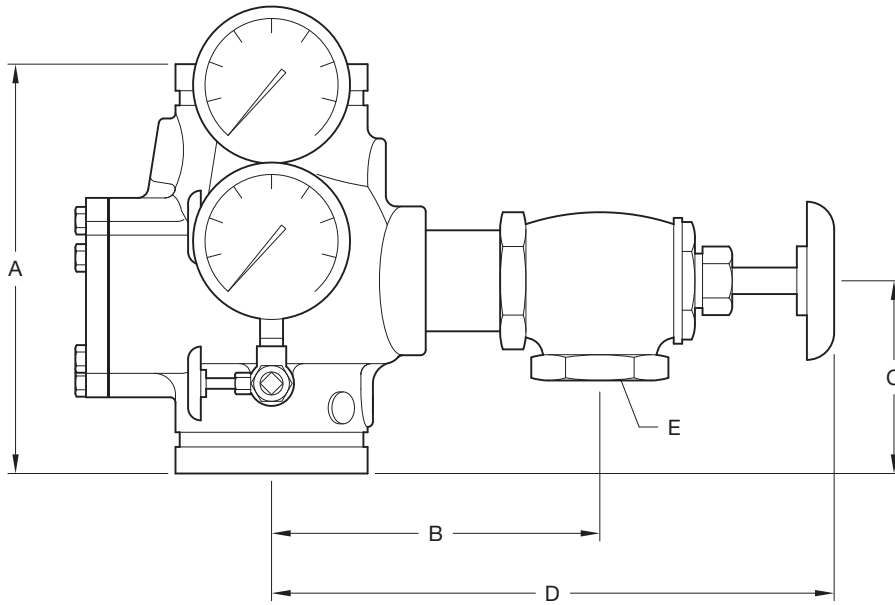

Nominal Pipe Size		Nominal Dimensions Inches (mm)				
ANSI Inches DN	O.D. Inches (mm)	A	B	C	D	E Inches NPT
2 DN50	2.375 (60,3)	6.75 (171,5)	5.87 (149,1)	3.25 (82,6)	9.52 (241,9)	1
2-1/2 DN65	2.875 (73,0)	8.00 (203,2)	6.66 (169,2)	3.87 (98,3)	10.80 (274,3)	1-1/4
76,1 DN65	- (76,1)	8.00 (203,2)	6.66 (169,2)	3.87 (98,3)	10.80 (274,3)	1-1/4
3 DN80	3.500 (88,9)	8.37 (212,6)	6.88 (174,8)	3.87 (98,3)	11.02 (279,9)	1-1/4
4 DN100	4.500 (114,3)	9.63 (244,6)	7.63 (193,7)	4.53 (115,1)	11.92 (302,7)	2
139,7 DN125	- (139,7)	10.50 (266,7)	8.13 (206,4)	4.90 (124,5)	12.42 (315,4)	2
5 DN125	5.563 (141,3)	10.50 (266,7)	8.13 (206,4)	4.90 (124,5)	12.42 (315,4)	2
165,1 DN150	- (165,1)	11.50 (292,1)	8.50 (215,8)	5.00 (127,0)	12.79 (324,8)	2
6 DN150	6.625 (168,3)	11.50 (292,1)	8.50 (215,8)	5.00 (127,0)	12.79 (324,8)	2
8 DN200	8.625 (219,1)	14.00 (355,6)	9.52 (241,7)	5.46 (138,7)	13.81 (350,7)	2
10 DN250	10.750 (273,1)	18.00 (457,2)	10.41 (264,3)	7.50 (190,5)	14.70 (373,3)	2
12 DN300	12.750 (323,9)	21.00 (533,4)	11.27 (286,1)	7.62 (193,5)	15.56 (395,2)	2

FIGURE 4
MODEL CV-1FR RISER CHECK VALVE WITH TRIM COMPONENTS
NOMINAL DIMENSIONS

P/N 59-591-1-020 2 Inch (DN50)			
NO.	DESCRIPTION	QTY.	P/N
1	300 psi/ 2000 kPa Water Pressure Gauge . . . 2	92-343-1-005	
2	1/4" Gauge Test Valve . . . 2	46-005-1-002	
3	1/4" Plug 2	CH	
4	1" Angle Valve 1	46-048-1-006	
5	1/4" x 2" Nipple 1	CH	
6	1/4" x 5" Nipple 1	CH	
7	1" x 3" Nipple 1	CH	

P/N 59-591-1-030 2-1/2 Inch (DN65) through 3 Inch (DN80)			
NO.	DESCRIPTION	QTY.	P/N
1	300 psi/ 2000 kPa Water Pressure Gauge . . . 2	92-343-1-005	
2	1/4" Gauge Test Valve . . . 2	46-005-1-002	
3	1/4" Plug 2	CH	
4	1-1/4" Angle Valve 1	46-048-1-007	
5	1/4" x 2" Nipple 1	CH	
6	1/4" x 5" Nipple 1	CH	
7	1-1/4" x 3" Nipple 1	CH	

P/N 59-591-1-080 4 Inch (DN100) through 12 Inch (DN300)			
NO.	DESCRIPTION	QTY.	P/N
1	300 psi/ 2000 kPa Water Pressure Gauge . . . 2	92-343-1-005	
2	1/4" Gauge Test Valve . . . 2	46-005-1-002	
3	1/4" Plug 2	CH	
4	2" Angle Valve 1	46-048-1-009	
5	1/4" x 2" Nipple 1	CH	
6	1/4" x 5" Nipple 1	CH	
7	2" x 3" Nipple 1	CH	

- NOTES:
1. All Fittings and Nipples are galvanized (Standard Order).
 2. CH: Common Hardware.

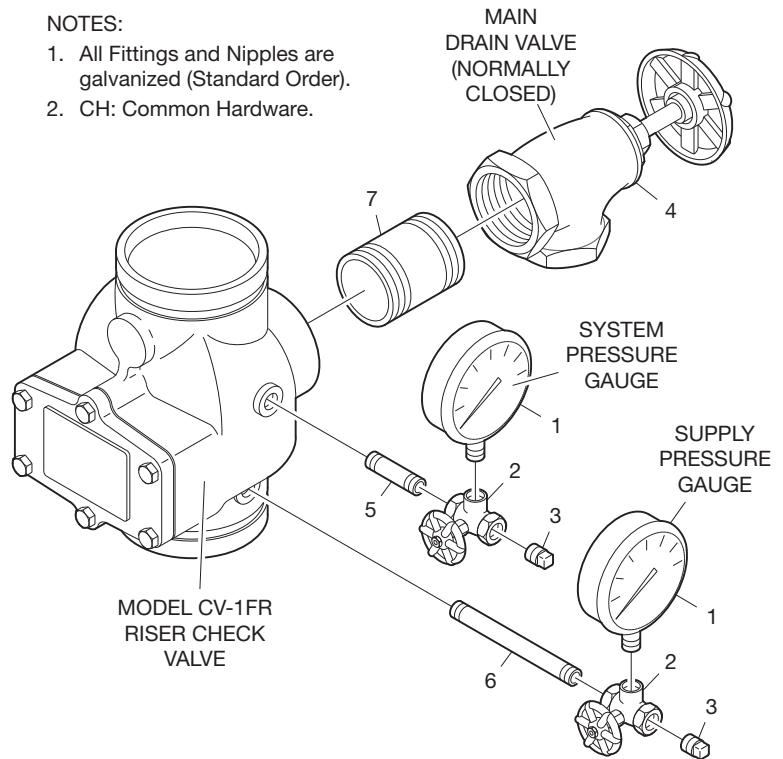
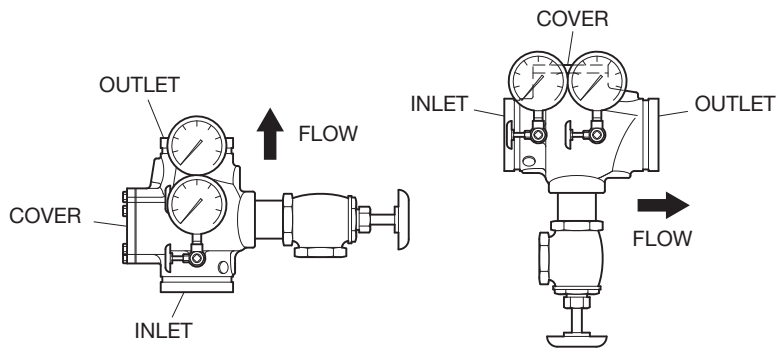

FIGURE 5
MODEL CV-1FR RISER CHECK VALVES
TRIM PARTS LIST



VERTICAL ORIENTATION HORIZONTAL ORIENTATION

FIGURE 6
MODEL CV-1FR RISER CHECK VALVES
INSTALLATION

Care and Maintenance

Before closing a fire protection system main control valve for maintenance work on the fire protection system that it controls, obtain permission to shut down the affected fire protection system from the proper authorities and notify all personnel who may be affected by this decision.

After placing a fire protection system in service, notify the proper authorities and advise those responsible for monitoring proprietary and/or central station alarms.

The owner is responsible for the inspection, testing, and maintenance of their fire protection system and devices in compliance with this document, as well as with the applicable standards of the NATIONAL FIRE PROTECTION ASSOCIATION (e.g., NFPA 25), in addition to the standards of any authority having jurisdiction. Contact the installing contractor or product manufacturer with any questions. Any impairments must be immediately corrected.

Automatic sprinkler systems are recommended to be inspected, tested, and maintained by a qualified Inspection Service in accordance with local requirements and/or national codes.

Ordering Procedure

Contact your local distributor for availability. When placing an order, indicate the full product name and Part Number (P/N).

Model CV-1FR Check Valves

Specify: Size and P/N (below):

2 in. (DN50)	P/N 59-590-1-020
2-1/2 in. (DN65)	P/N 59-590-1-025
76,1 mm (DN65)	P/N 59-590-1-076
3 in. (DN80)	P/N 59-590-1-030
4 in. (DN100)	P/N 59-590-1-040
139,7 mm (DN125)	P/N 59-590-1-139
5 in. (DN125)	P/N 59-590-1-050
165,1 mm (DN150)	P/N 59-590-1-165
6 in. (DN150)	P/N 59-590-1-060
8 in. (DN200)	P/N 59-590-1-080
10 in. (DN250)	P/N 59-590-1-100
12 in. (DN300)	P/N 59-590-1-120

Model CV-1FR Riser Check Valve Trim Assembly

Specify: Size and P/N (below):

2 in. (DN50)	P/N 59-591-1-020
2-1/2 in. (DN65)	P/N 59-591-1-030
76,1 mm (DN65)	P/N 59-591-1-030
3 in. (DN80)	P/N 59-591-1-030
4 in. (DN100)	P/N 59-591-1-080
139,7 mm (DN125)	P/N 59-591-1-080
5 in. (DN125)	P/N 59-591-1-080
165,1 mm (DN150)	P/N 59-591-1-080
6 in. (DN150)	P/N 59-591-1-080
8 in. (DN200)	P/N 59-591-1-080
10 in. (DN250)	P/N 59-591-1-080
12 in. (DN300)	P/N 59-591-1-080