



Type EA-1 PROTECTOSPRAY Directional Spray Nozzles, Automatic, Medium Velocity

General Description

The TYCO Type EA-1 PROTECTOSPRAY Directional Spray Nozzles are automatic (frangible bulb) directional spray nozzles designed for use in water spray fixed systems for fire protection applications. They are external deflector-type nozzles that discharge a uniformly filled cone of medium velocity water droplets.

The Type EA-1 PROTECTOSPRAY Directional Spray Nozzles are effective in covering exposed vertical, horizontal, curved, and irregular shaped surfaces in a cooling spray to prevent excessive absorption of heat from an external fire and possible structural damage or spread of fire to the protected equipment. However, use of an automatic nozzle requires consideration of the response time of the thermal element.

The Type EA-1 PROTECTOSPRAY Directional Spray Nozzles are also especially effective for area coverage and are sometimes used in lieu of standard sprinklers where directional spray is considered more appropriate. In some applications, depending on water design density requirements, the Type EA-1 Nozzles are also used for fire control or extinguishment.

The Type EA-1 PROTECTOSPRAY Directional Spray Nozzles are available in three orifice sizes and a wide variety of spray angles (included angle of discharge), as well as temperature ratings

to provide versatility in system design.

It is recommended that the end user be consulted with respect to the suitability of the materials of construction and finish for any given corrosive environment. The effects of ambient temperature, concentration of chemicals, and gas/chemical velocity should be considered, at a minimum, along with the corrosive nature to which the sprinklers may be exposed.

The Type EA-1 PROTECTOSPRAY Directional Spray Nozzle is a re-designation for the Gem Type EA-1.

NOTICE

The Type EA-1 PROTECTOSPRAY Directional Spray Nozzles described herein must be installed and maintained in compliance with this document, as well as with the applicable standards of the National Fire Protection Association, in addition to the standards of any authorities having jurisdiction. Failure to do so may impair the performance of these devices.

The design of individual water spray fixed systems can vary considerably, depending on the characteristics and nature of the hazard, the basic purpose of the spraying system, the configuration of the hazard, and wind/draft conditions. Because of these variations, as well as the wide range of available nozzle spray characteristics, the design of water spray fixed systems for fire protection must only be performed by experienced designers who thoroughly understand the limitations as well as capabilities of such systems.

The owner is responsible for maintaining their fire protection system and devices in proper operating condition. Contact the installing contractor or product manufacturer with any questions.

Technical Data

Approvals
UL and C-UL Listed
FM Approved



Maximum Working Pressure

175 psi (12,1 bar)
(Also refer to Figure 2, Note 2)

Discharge Coefficient

Refer to Table A

Spray Angles

Refer to Table B

Temperature Rating

Refer to Table C

Finish and Material

Refer to Table D

Thread Connection

1/2 in. NPT

Physical Characteristics

Frame	Bronze
Bushing (K=1.4 & K=2.8)	Brass
Deflector	Bronze
Pin	Brass
Bulb (11 mm dia.)	Glass
Bulb Seats	Bronze
Spacer	Bronze
Button	Bronze
Spring Plates	Inconel
Gaskets	Copper

Operation

The glass bulb contains a fluid that expands when exposed to heat. When the rated temperature is reached, the fluid expands sufficiently to shatter the glass bulb, allowing the nozzle to activate and water to flow.

IMPORTANT

Refer to Technical Data Sheet TFP2300 for warnings pertaining to regulatory and health information.

Always refer to Technical Data Sheet TFP700 for the "INSTALLER WARNING" that provides cautions with respect to handling and installation of sprinkler systems and components. Improper handling and installation can permanently damage a sprinkler system or its components and cause the sprinkler to fail to operate in a fire situation or cause it to operate prematurely.

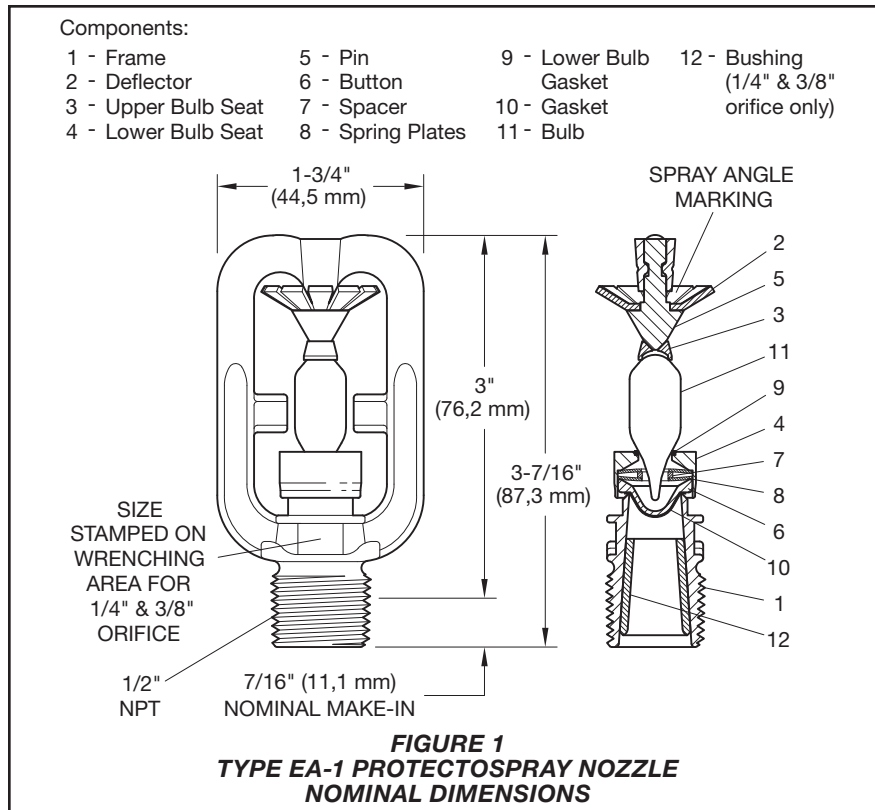

ORIFICE SIZE Inches	MINIMUM DIAMETER Inches (mm)	K-FACTOR	
		GPM/psi ^{1/2}	LPM/bar ^{1/2}
1/4	0.220 (5,59)	1.4	20,2
3/8	0.312 (7,92)	2.8	40,3
1/2	0.435 (11,05)	5.6	80,6

TABLE A
SELECTION OF ORIFICE SIZES

65°	95°	80°	110°	125°	140°	160°	180°
-----	-----	-----	------	------	------	------	------

TABLE B
SELECTION OF SPRAY ANGLES

Design Criteria

Nozzle Placement

Where direct impingement of water spray onto all of the protected surface is required by the authority having jurisdiction, the nozzles are to be spaced and directed so that their spray patterns will completely cover the plane-of-protection with the minimum required average density. However, it is recommended that indoor nozzle spacing be 12 ft (3,7 m) or less and that outdoor nozzle spacing be 10 ft (3,0 m) or less. Where rundown or slippage is planned, for example, exposure protec-

tion of vessels per NFPA 15, the above recommended indoor and outdoor spacings also apply.

When used for protecting the surfaces of a vessel, for example, the nozzles are positioned normal to and approximately 2 ft (0,6 m) from the surface. This approach, in conjunction with a properly selected spray angle, will tend to make more effective use of the spray as well as help minimize the disturbance effects of wind/draft conditions on the water spray patterns.

Spray Patterns

The Design Spray Profiles for the nozzle spray angles of 65 to 180 degrees are shown in Figure 2 and apply to discharge pressures of 20 to 60 psi (1,4

TEMPERATURE RATING	FRAME COLOR CODE	BULB CODE COLOR LIQUID
135°F (57°C)	Unpainted	Orange
175°F (79°C)	White	Yellow
250°F (121°C)	Blue	Blue
325°F (163°C)	Red	Mauve
400°F (204°C)	Green	Black
500°F (260°C)	Orange	Black

TABLE C
SELECTION OF TEMPERATURE RATINGS

FINISH & MATERIAL	TEMPERATURE RATINGS
Natural Finish Bronze	All Ratings
Chrome Plated Bronze	135°F (57°C) 175°F (79°C) 250°F (121°C) 325°F (163°C)
Lead Coated Bronze	135°F (57°C) 175°F (79°C)
Corrosion-Resistant Wax-Coated Bronze	135°F (57°C) 175°F (79°C)

TABLE D
SELECTION OF FINISH AND MATERIALS

to 4,1 bar). Discharge pressures in excess of 60 psi (4,1 bar) will result in a decrease in coverage area because the spray patterns tend to draw inwards at higher pressures. Refer inquiries on higher discharge pressures to the Technical Services Department.

The maximum axial distances between the nozzle tip and plane-of-protection, for exposure protection, are given in Table E and F. When the axial distance from the nozzle tip to the plane-of-protection is 2 ft (0,6 m) or less, the Design Spray Profile is the same as the nominal spray angles of 65 to 140 degrees.

Heat Sensitivity

Because the Type EA-1 PROTECTOSPRAY Directional Spray Nozzles are automatic nozzles, they must be located with consideration of their ability to detect abnormal temperature increases due to fire. Therefore, it is recommended that NFPA 13 be reviewed with respect to the rules that define the permitted distance below ceilings and the spacing limitations for standard coverage automatic sprinklers as a function of occupancy hazard.

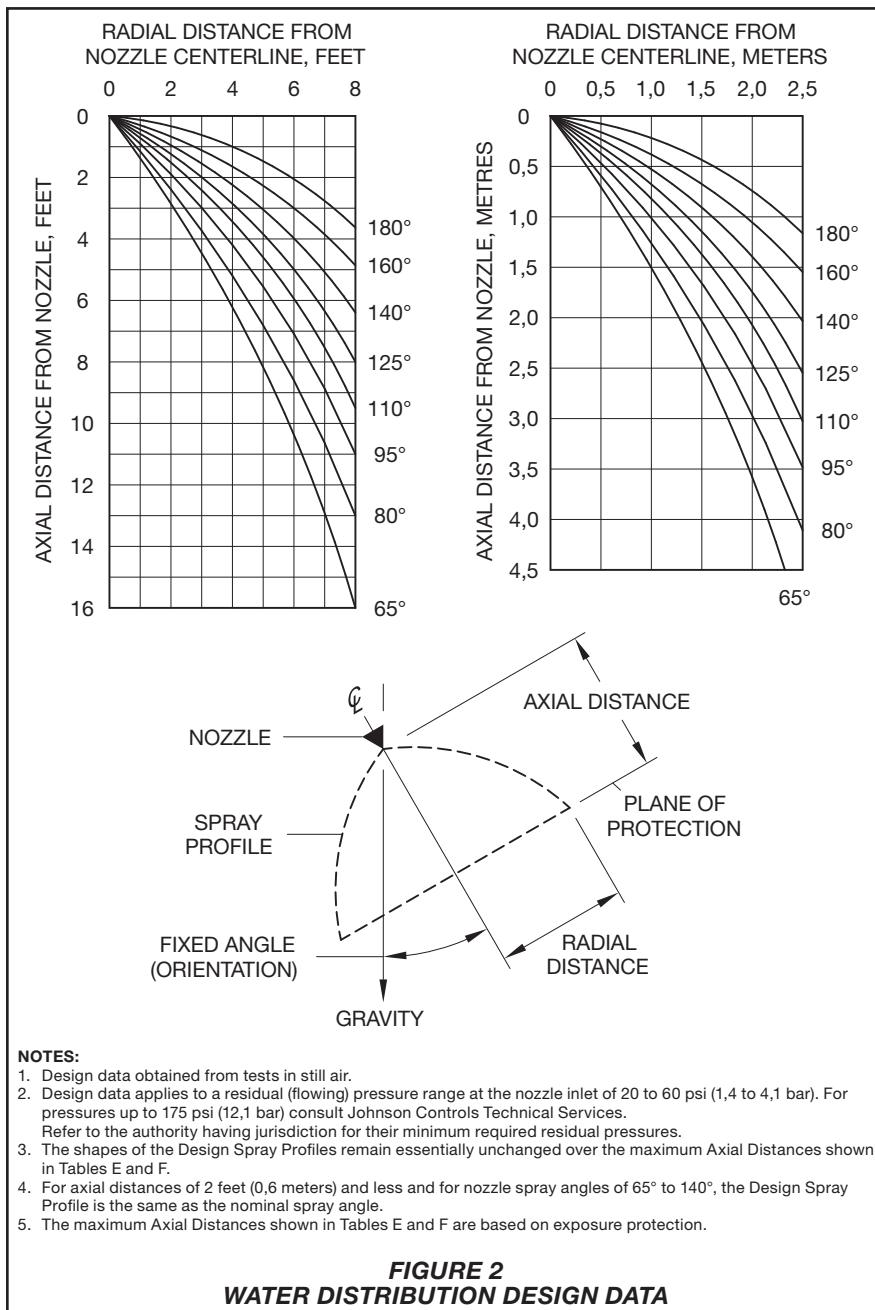

Main Pipeline Strainers

Main pipeline strainers per NFPA 15 are required for systems utilizing nozzles with a flow path less than 3/8 in. (9,5 mm) diameter, that is, K=1.4 (Table A), and for any system where the water is likely to contain obstructive material.

Installation

The TYCO Type EA-1 PROTECTO-SPRAY Directional Spray Nozzles must be installed in accordance with this section.

NOTICE

Do not install an Type EA-1 Nozzle if the bulb is cracked or there is a loss of liquid from the bulb. With the sprinkler held horizontally, a small air bubble should be present. The diameter of the air bubble is approximately 3/32 in. (2,4 mm) for the 135°F (57°C) to 1/4 in. (6,4 mm) for the 500°F (260°C) temperature ratings.

Obtain a leak-tight 1/2 in. NPT nozzle joint by applying a minimum-to-maximum torque of 7 to 14 ft-lb (9,5 to 19,0 N·m). Higher levels of torque can distort the nozzle inlet and cause leakage or impairment of the nozzle.

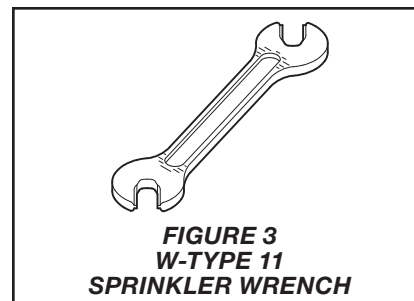

Step 1. With pipe-thread sealant applied to the pipe threads, hand-tighten the nozzle into the nozzle fitting.

Step 2. Tighten the nozzle into the nozzle fitting using only the W-Type 11 Sprinkler Wrench (Figure 3), except that an 8 in. or 10 in. adjustable crescent wrench is to be used for wax-coated nozzles. With reference to Figure 1, the W-Type 11 Sprinkler Wrench or the adjustable crescent wrench, as applicable, is to be applied to the wrenching area.

When installing wax-coated nozzles with the adjustable crescent wrench, exercise additional care to prevent damage to the wax coating on the nozzle wrenching area or frame arms and, consequently, exposure of bare metal to the corrosive environment. Sufficiently widen the jaws of the wrench enough to pass over the wrenching area without damaging the wax coating. Before wrench-tightening the nozzle, adjust the jaws of the wrench to contact the nozzle wrenching area. After wrench-tightening the nozzle, loosen the wrench jaws before removing the wrench.

After installation, inspect the nozzle wrenching area and frame arms and retouch (repair) the wax coating whenever the coating has been damaged and bare metal is exposed. Retouch the wax coating on the wrenching area by gently applying a heated 1/8 in. diameter steel rod to the areas of wax that have been damaged, smoothing it back over areas where bare metal is exposed.

NOTICE

Only retouching of the wax coating applied to the wrenching area and frame arms is permitted, and the retouching is to be performed only at the time of the initial nozzle installation.

The steel rod should be heated only to the point at which it can begin to melt the wax, and appropriate precautions need to be taken when handling the heated rod in order to prevent the installer from being burned.

Maximum Axial Distance For 65° Spray Angle In Feet and inches				Maximum Axial Distance For 80° Spray Angle In Feet and inches				Maximum Axial Distance For 95° Spray Angle In Feet and inches				Maximum Axial Distance For 110° Spray Angle In Feet and inches			
Fixed Angle	Orifice Size			Fixed Angle	Orifice Size			Fixed Angle	Orifice Size			Fixed Angle	Orifice Size		
	1/4 in.	3/8 in.	1/2 in.		1/4 in.	3/8 in.	1/2 in.		1/4 in.	3/8 in.	1/2 in.		1/4 in.	3/8 in.	1/2 in.
0°	11-9	14-0	15-0	0°	10-0	13-0	14-0	0°	7-0	10-9	12-3	0°	6-0	10-0	11-0
30°	10-0	12-3	13-0	30°	8-3	11-3	11-6	30°	6-3	10-0	10-6	30°	5-6	8-9	9-9
45°	9-0	11-3	12-3	45°	7-3	10-6	10-9	45°	6-0	9-6	9-6	45°	5-3	8-3	8-9
60°	8-6	10-6	11-9	60°	6-9	9-9	10-3	60°	5-9	9-0	9-0	60°	5-0	7-6	8-3
90°	7-6	10-0	10-9	90°	6-0	8-9	9-6	90°	5-0	7-9	8-6	90°	4-6	6-6	7-9
120°	6-3	7-6	8-9	120°	5-3	6-3	7-6	120°	4-0	5-3	6-3	120°	3-6	4-3	5-6
135°	5-9	6-3	7-9	135°	4-9	5-3	6-6	135°	3-6	4-3	5-3	135°	3-0	3-6	4-6
150°	5-3	5-6	7-0	150°	4-3	4-6	5-6	150°	3-3	3-9	4-6	150°	2-9	3-0	3-9
180°	4-9	5-0	6-3	180°	3-9	4-3	5-0	180°	3-0	3-3	4-0	180°	2-6	2-9	3-6

Maximum Axial Distance For 125° Spray Angle In Feet and inches				Maximum Axial Distance For 140° Spray Angle In Feet and inches				Maximum Axial Distance For 160° Spray Angle In Feet and inches				Maximum Axial Distance For 180° Spray Angle In Feet and inches			
Fixed Angle	Orifice Size			Fixed Angle	Orifice Size			Fixed Angle	Orifice Size			Fixed Angle	Orifice Size		
	1/4 in.	3/8 in.	1/2 in.		1/4 in.	3/8 in.	1/2 in.		1/4 in.	3/8 in.	1/2 in.		1/4 in.	3/8 in.	1/2 in.
0°	4-6	7-3	10-0	0°	4-0	6-0	9-3	0°	3-6	5-0	7-0	0°	3-0	3-9	6-0
30°	4-3	6-9	8-3	30°	3-6	5-9	7-0	30°	3-3	4-9	5-6	30°	2-9	3-6	5-0
45°	3-9	6-3	7-3	45°	3-3	5-3	6-3	45°	2-9	4-3	4-9	45°	2-6	3-0	4-3
60°	3-3	5-6	6-6	60°	2-9	4-9	5-6	60°	1-9	3-9	4-6	60°	2-3	2-9	3-9
90°	2-6	5-0	5-9	90°	2-0	4-0	4-9	90°	1-6	3-3	3-6	90°	1-3	1-9	3-0
120°	2-3	3-3	4-0	120°	1-9	2-3	3-3	120°	1-3	1-9	3-0	120°	0-9	1-0	2-6
135°	2-0	2-6	3-6	135°	1-6	1-6	2-6	135°	1-0	1-3	2-6	135°	0-6	0-9	2-3
150°	1-9	2-0	3-0	150°	1-6	1-3	2-3	150°	1-0	1-0	1-6	150°	0-6	0-6	1-0
180°	1-9	1-9	2-6	180°	1-3	1-3	1-9	180°	1-0	0-9	1-3	180°	0-6	0-6	0-9

TABLE E
TYPE EA-1 PROTECTOSPRAY DIRECTIONAL SPRAY NOZZLES
MAXIMUM AXIAL DISTANCE IN FEET AND INCHES BETWEEN
NOZZLE TIP AND PLANE-OF-PROTECTION FOR EXPOSURE PROTECTION

Care and Maintenance

The TYCO Type EA-1 PROTECTOSPRAY Directional Spray Nozzles must be maintained and serviced in accordance with this section.

Before closing a fire protection system main control valve for maintenance work on the fire protection system that it controls, obtain permission to shut down the affected fire protection system from the proper authorities and notify all personnel who may be affected by this action.

Type EA-1 PROTECTOSPRAY Directional Spray Nozzles must never be painted, plated, coated or altered in any way after leaving the factory; otherwise, the spray performance and heat sensitivity may be impaired.

Exercise care to avoid damage to the nozzles before, during, and after installation. Replace nozzles damaged by dropping, striking, wrench twist/slip-page, or the like.

Frequent visual inspections are recommended to be initially performed for nozzles installed in potentially corrosive atmospheres to verify the integrity of the materials of construction and finish as they may be affected by the corrosive conditions present for a given installation. Thereafter, annual inspections per NFPA 25 are required.

The owner is responsible for the inspection, testing, and maintenance of their fire protection system and devices in compliance with this document, as well as with the applicable standards of the National Fire Protection Association (e.g., NFPA 25), in addition to the standards of any other authorities

having jurisdiction. Contact the installing contractor or product manufacturer with any questions.

Water spray fixed systems are recommended to be inspected, tested, and maintained by a qualified Inspection Service in accordance with local requirements and/or national codes.

Maximum Axial Distance For 65° Spray Angle In Meters				Maximum Axial Distance For 80° Spray Angle In Meters				Maximum Axial Distance For 95° Spray Angle In Meters				Maximum Axial Distance For 110° Spray Angle In Meters			
Fixed Angle	Orifice Size			Fixed Angle	Orifice Size			Fixed Angle	Orifice Size			Fixed Angle	Orifice Size		
	1/4 in.	3/8 in.	1/2 in.		1/4 in.	3/8 in.	1/2 in.		1/4 in.	3/8 in.	1/2 in.		1/4 in.	3/8 in.	1/2 in.
0°	3,6	4,3	4,6	0°	3,0	4,0	4,3	0°	2,7	3,3	3,7	0°	1,8	3,0	3,4
30°	3,0	3,7	4,0	30°	2,5	3,4	3,5	30°	1,9	3,0	3,2	30°	1,7	2,7	3,0
45°	2,7	3,4	3,7	45°	2,2	3,2	3,3	45°	1,8	2,9	2,9	45°	1,6	2,5	2,7
60°	2,6	3,2	3,6	60°	2,1	3,0	3,1	60°	1,8	2,7	2,7	60°	1,5	2,3	2,5
90°	2,3	3,0	3,3	90°	1,8	2,7	2,9	90°	1,5	2,4	2,6	90°	1,4	2,0	2,4
120°	1,9	2,3	2,7	120°	1,6	1,9	2,3	120°	1,2	1,6	1,9	120°	1,1	1,3	1,7
135°	1,8	1,9	2,4	135°	1,4	1,6	2,0	135°	1,1	1,3	1,6	135°	0,9	1,1	1,4
150°	1,6	1,7	2,1	150°	1,3	1,4	1,7	150°	1,0	1,1	1,4	150°	0,8	0,9	1,1
180°	1,4	1,5	1,9	180°	1,1	1,3	1,5	180°	0,9	1,0	1,2	180°	0,8	0,8	1,1

Maximum Axial Distance For 125° Spray Angle In Meters				Maximum Axial Distance For 140° Spray Angle In Meters				Maximum Axial Distance For 160° Spray Angle In Meters				Maximum Axial Distance For 180° Spray Angle In Meters			
Fixed Angle	Orifice Size			Fixed Angle	Orifice Size			Fixed Angle	Orifice Size			Fixed Angle	Orifice Size		
	1/4 in.	3/8 in.	1/2 in.		1/4 in.	3/8 in.	1/2 in.		1/4 in.	3/8 in.	1/2 in.		1/4 in.	3/8 in.	1/2 in.
0°	1,4	2,2	3,0	0°	1,2	1,8	2,8	0°	1,1	1,5	2,1	0°	0,9	1,1	1,8
30°	1,3	2,1	2,5	30°	1,1	1,8	2,1	30°	1,0	1,4	1,7	30°	0,8	1,1	1,5
45°	1,1	1,9	2,2	45°	1,0	1,6	1,9	45°	0,8	1,3	1,4	45°	0,8	0,9	1,3
60°	1,0	1,7	2,0	60°	0,8	1,4	1,7	60°	0,5	1,1	1,4	60°	0,7	0,8	1,1
90°	0,8	1,5	1,8	90°	0,6	1,2	1,4	90°	0,5	1,0	1,1	90°	0,4	0,5	0,9
120°	0,7	1,0	1,2	120°	0,5	0,7	1,0	120°	0,4	0,5	0,9	120°	0,2	0,3	0,8
135°	0,6	0,8	1,1	135°	0,5	0,5	0,8	135°	0,3	0,4	0,8	135°	0,2	0,2	0,7
150°	0,5	0,6	0,9	150°	0,5	0,4	0,7	150°	0,3	0,3	0,5	150°	0,2	0,2	0,3
180°	0,5	0,5	0,8	180°	0,4	0,4	0,5	180°	0,2	0,3	0,4	180°	0,2	0,2	0,2

TABLE F
TYPE EA-1 PROTECTOSPRAY DIRECTIONAL SPRAY NOZZLES
MAXIMUM AXIAL DISTANCE IN METERS BETWEEN
NOZZLE TIP AND PLANE-OF-PROTECTION FOR EXPOSURE PROTECTION

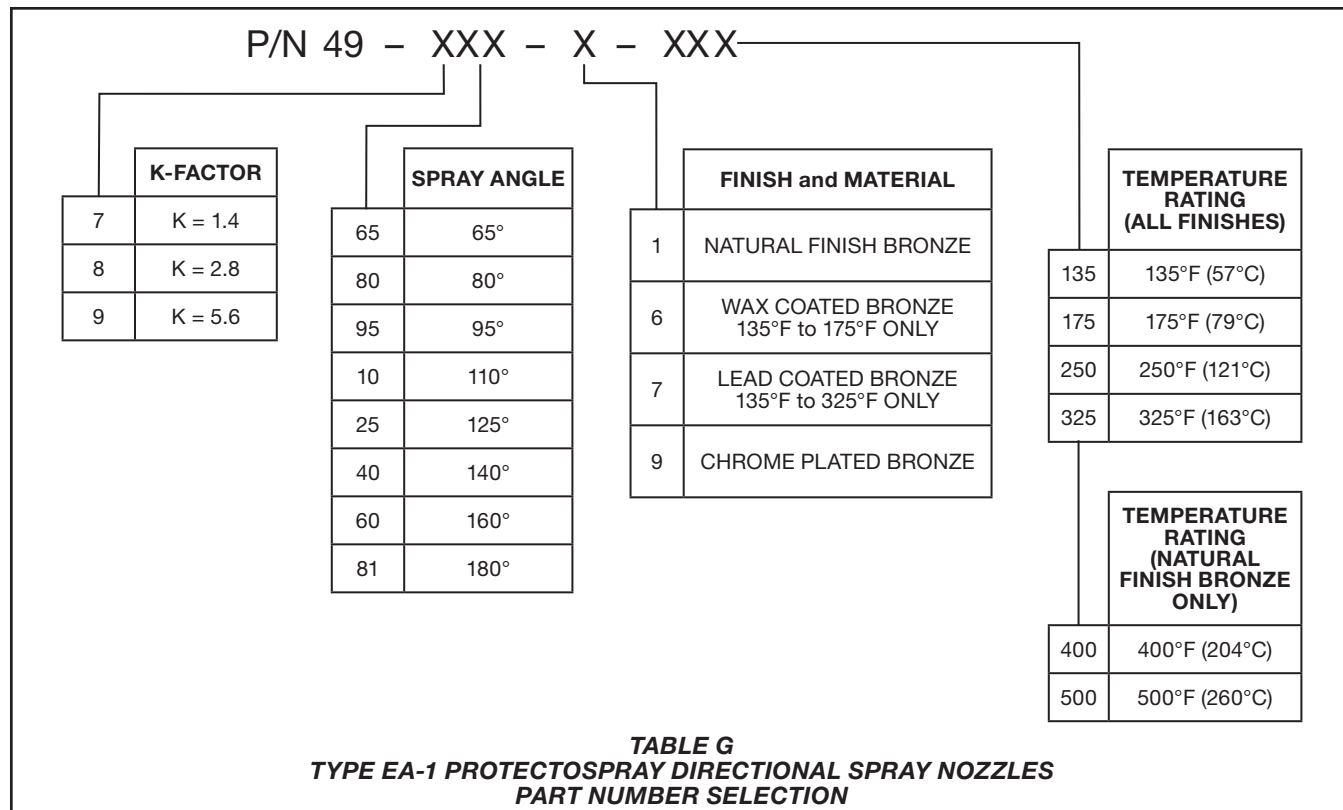

Ordering Procedure

When placing an order, indicate the full product name and part number (P/N). Contact your local distributor for availability.

Type EA-1 PROTECTOSPRAY Directional Spray Nozzle

Specify:

- (1.4, 2.8, or 5.6) K-factor orifice
- temperature rating
- finish/coating and material
- (degree) spray angle
- P/N (from Table G)

Sprinkler Wrench

Specify: W-Type 11 Sprinkler Wrench,
P/N 56-452-1-001