



Model WS Specific Application Window Sprinklers Horizontal and Pendent Vertical Sidewall 5.6 K-factor

General Description

The TYCO Model WS Specific Application Window Sprinklers are fast response, glass bulb-type spray sprinklers available in Horizontal Sidewall and Pendent Vertical Sidewall models.

These sprinklers are the first to be specifically Listed to provide complete wetting and coverage for heat strengthened, tempered, or ceramic glass windows using closed sprinklers. As part of the testing, the gas flow required to achieve the time/temperature relationship specified in ASTM E119 was established in a test furnace without sprinkler protection. A window assembly protected with the TYCO Model WS Window Sprinklers was then installed in the test furnace, and the same gas flow conditions were maintained for a two-hour test period. No cracking or visible damage to the window was permitted during the test period, even when a hose stream was directed at the window.

The success of the Model WS Window Sprinklers is based on their fast response thermal sensitivity and on their specially designed deflectors that ensure that the spray pattern wets the entire surface of the window.

Based on successful testing, the Model WS Window Sprinklers can be used as interior protection of windows or glazing in a sprinklered building or non-sprinklered building in accordance

with Section 104 of the IBC (“Alternate Materials, Design and Methods of Construction and Equipment”). Also, the Model WS Window Sprinklers can be used as an open sprinkler for “Outside Sprinkler Protection against Exposure Fire”, using the design requirements of NFPA.

As with any specific application sprinkler, the installation instructions included in this data sheet must be precisely followed. If there are additional local or jurisdictional installation standards/codes for window sprinklers on glazed window systems, this document does not relieve the designer/installer from these requirements. Consult your local jurisdiction to verify if or when these additional guidelines must be followed.

NOTICE

TYCO Model WS Specific Application Window Sprinklers described herein must be installed and maintained in compliance with this document, as well as with the applicable standards recognized by the approval agency, in addition to the standards of any authorities having jurisdiction. Failure to do so may impair the performance of these devices.

The owner is responsible for maintaining their fire protection system and devices in proper operating condition. Contact the installing contractor or product manufacturer with any questions.

Sprinkler Identification Number (SIN)

TY3388 - Horizontal Sidewall
TY3488 - Pendent Vertical Sidewall

TY3388 is a re-designation for C3388
TY3488 is a re-designation for C3488



IMPORTANT

Refer to Technical Data Sheet TFP2300 for warnings pertaining to regulatory and health information.

Always refer to Technical Data Sheet TFP700 for the “INSTALLER WARNING” that provides cautions with respect to handling and installation of sprinkler systems and components. Improper handling and installation can permanently damage a sprinkler system or its components and cause the sprinkler to fail to operate in a fire situation or cause it to operate prematurely.

Technical Data

Approvals

UL and C-UL Listed
NYC under MEA 289-04-E

Approvals only apply to the service conditions indicated in the Design Criteria section.

Additional Recognition

ICC Evaluation Service (ESR-2397)
Ontario Building Code

Pipe Thread Connection

1/2 in. NPT

Discharge Coefficient

$K=5.6 \text{ GPM/psi}^{1/2}$ (80,6 LPM/bar^{1/2})

Temperature Ratings

155 °F (68 °C)
200 °F (93 °C)

Finish

Natural Brass
Signal White (RAL9003) Polyester
Jet Black (RAL9005) Polyester
Chrome Plated

Physical Characteristics

Frame	Brass
Button	Bronze/Copper
Sealing Assembly ..	Beryllium Nickel w/TEFLON
Bulb	Glass (3 mm dia.)
Compression Screw ..	Brass
Deflector	Brass/Bronze

Operation

The glass bulb contains a fluid that expands when exposed to heat. When the rated temperature is reached, the fluid expands sufficiently to shatter the glass bulb, allowing the sprinkler to activate and water to flow.

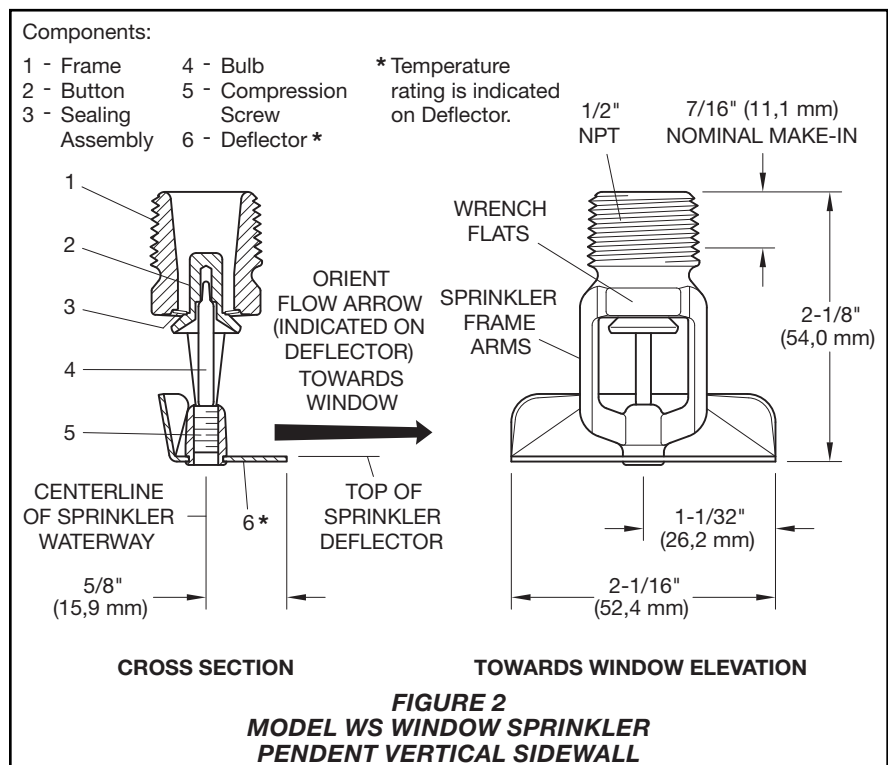
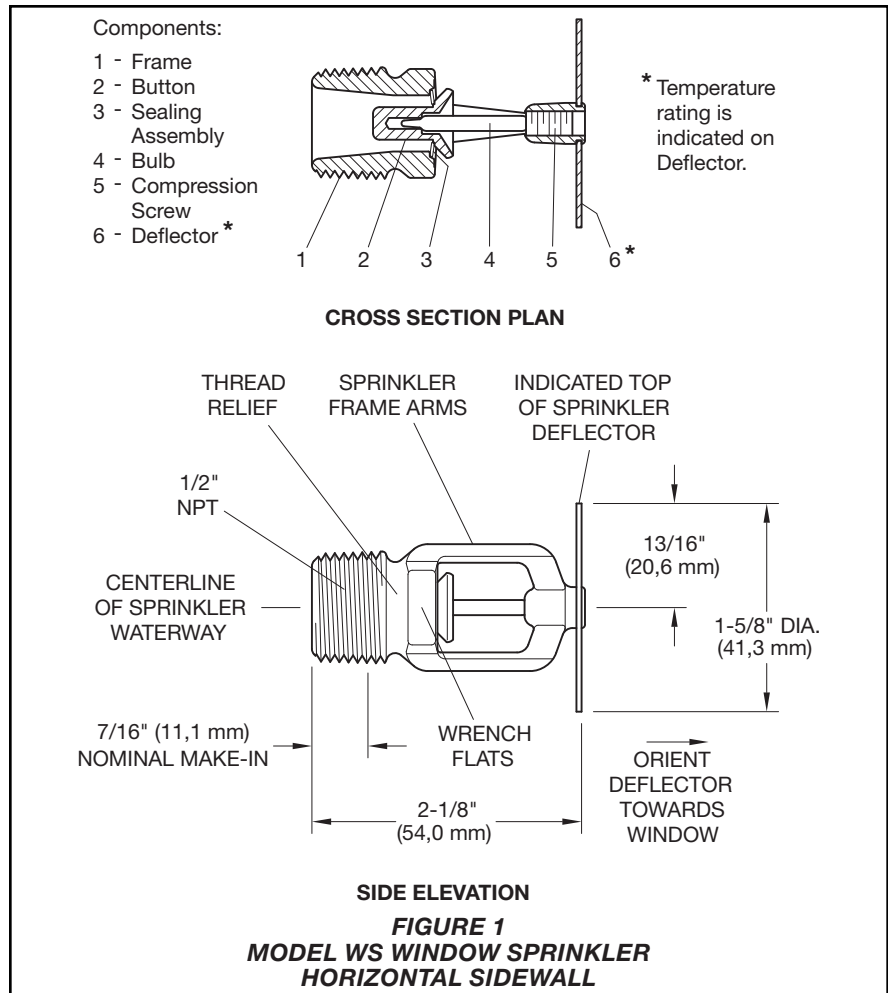

Design Criteria

The TYCO Model WS Specific Application Window Sprinklers are UL and C-UL Listed and NYC Approved (MEA 335-01-E) for use as “Specific Application Window Sprinkler” and as open sprinklers for “Outside” use.

These sprinklers are also recognized by Underwriters Laboratories of Canada (ULC), and the Ontario Building Code for use in the Province of Ontario, Canada as providing a two-hour equivalency for a fire separation assembly when installed in accordance with this code.

Area of Use

When acceptable to the Authority Having Jurisdiction and unless modified by a local jurisdictional standard or code mentioned previously, the TYCO Model WS Window Sprinklers may be used in either a sprinklered or unsprinklered building to protect non-operable window openings that are part of a fire separation provided:

- in an interior fire separation, the window sprinklers are installed on both sides of the window in the fire separation (Figure 3A-1),
- in jurisdictions where exterior spatial separation (that is, separation from adjacent space) is defined as protecting an adjacent building from a fire in your building, window sprinklers are installed on the interior side of the building (Figure 3A-2), or
- in jurisdictions where exterior spatial separation is defined as protecting your building from a fire in an adjacent building (that is, exposure protection), open window sprinklers are installed on the exterior side of the building (Figure 3A-3).

System Protection Type

- Interior: Wet Systems
- Outside Exposure: Deluge

Glass Type

The following types and thicknesses of glass are recognized for use with TYCO Model WS Window Sprinklers:

- Non-operable, heat-strengthened, tempered, single-glazed (single pane), not less than 1/4 in. (6 mm) thick;
- Non-operable, heat-strengthened, tempered, double-glazed (double pane or insulated), not less than 1/4 in. (6 mm) thick;
- Non-operable, UL Classified and labeled FireLite Plus WS ceramic glass by Technical Glass Products (TGP), not less than 5/16 in. (8 mm) thick; or,

NOTE: Refer to *FireLite Plus WS ceramic glass technical data sheet* for other classification limitations at www.fireglass.com.

- Non-operable, stronger glass window assemblies, not less than 1/4 in. (6 mm) thick.

Type of Window Frame/Mullion

Non-combustible Frame with a standard EPDM rubber gasket seal

Vertical joints of glass panes must be connected by butt-joints using a silicone sealant between the individual panes or by Noncombustible Mullions.

(Refer to Figures 3B-1 and 3B-2)

Maximum Length of Window Assembly

Unlimited

Maximum Height of Window Assembly

13 ft (3,96 m)

(Refer to Figures 3C and 3D)

Maximum Distance Between Window Sprinklers

8 ft (2,44 m)

(Refer to Figures 3B-1 and 3B-2)

Minimum Distance Between Window Sprinklers

6 ft (1,83 m) unless separated by a baffle or mullion of sufficient depth to act as a baffle.

A mullion will act as a baffle, when in the case of the Pendent Vertical Sidewall, the mullion extends to the back of the sprinkler deflector, and in the case of the Horizontal Sidewall, the mullion extends to the sprinkler wrench flat.

(Refer to Figures 3B-1 and 3B-2)

Minimum Distance from Standard Sprinklers

6 ft (1,83 m) unless separated by a baffle

Sprinkler Location

- Mullioned Glazing Assemblies: Locate window sprinklers within each mullioned glazing segment. Refer to Figure 3B-1.
- Butt-Jointed Glazing Assemblies: Locate window sprinklers on maximum 8 ft (2,44 m) centers. Refer to Figure 3B-2.

Maximum Distance from Vertical Mullion

4 ft (1,22 m)

(Refer to Figure 3B-1)

Minimum Distance from Vertical Mullions

4 in. (101,6 mm)

(Refer to Figure 3B-1)

Intermediate Horizontal Mullions

Intermediate Horizontal Mullions were not tested with the Model WS Window Sprinklers. Their use is outside the scope of the “Specific Application” Listing for the window sprinklers. Refer to Figure 3B-3.

Deflector Location

Sprinkler Deflectors must be located as described below in order to ensure that the entire surface of the glass window is covered. Sprinkler Deflectors are positioned with respect to the window frame, not the ceiling.

- Horizontal Sidewall: Locate within the outside edge of the window frame from 1/2 in. to 4 in. (12,7 mm to 101,6 mm) away from the glass and 2 in. ± 1 in. (50,8 mm ± 25,4 mm) down from the top of the exposed glass. Refer to Figure 3C.
- Pendent Vertical Sidewall: Locate 4 in. to 12 in. (101,6 mm to 304,8 mm) from the face of the glass and 3 in. ± 1 in. (76,2 mm ± 25,4 mm) down from the top of exposed glass. Refer to Figure 3D.

Minimum Clearance from Face of Glass to Combustible Materials

For glass types other than FireLite Plus WS ceramic glass by TGP, all combustible materials shall be kept 2 in. (50,8 mm) from the front face of the glass. This can be accomplished by a minimum 36 in. (914,4 mm) pony wall or other method acceptable to the authority having jurisdiction.

Escutcheon Assemblies

The Model WS Window Sprinklers can be used with any metallic flush or extended escutcheons, provided the dimensions from the sprinkler deflector to the window frame and glass surface as specified in this data sheet are maintained. These sprinklers are not listed for recessed applications.

Recommended Hydraulic Requirements

The authority having jurisdiction should be consulted to determine the hydraulic requirements for each installation.

Interior Protection Sprinklered Building

Identify which compartmented area has the most hydraulically demanding window sprinklers. Calculate up to the most demanding 46.5 linear feet of Model WS Window Sprinklers on one side of the glazing. The 46.5 linear feet (14,2 linear meters) is based upon 1.2 x the square root of the system area of operation, when the system area of operation is 1500 sq.-ft. in accordance with NFPA 13 Light/Ordinary Hazard density curves.

Where the area of Glazing is less than 14.2 linear meters, all window sprinklers on one side shall be calculated.

If an area reduction for quick response sprinklers is utilized, the linear length of the calculated window sprinklers may be reduced, but in no case shall be less than 36 linear feet (1.2 x $\sqrt{900}$).

If a single fire can be expected to operate Model WS Window Sprinklers and sprinklers within the design area of a hydraulically calculated system, the water demand of the window sprinklers shall be added to the water demand of the hydraulic calculations and shall be balanced to the calculated area demand.

If the window sprinklers are located in an area other than the hydraulic design area, the demand of the window sprinklers is not required to be added to the demand of the remote hydraulic design area. However, it is necessary to prove hydraulically the simultaneous operation of the Model WS Window Sprinklers and the ceiling sprinklers adjacent to the window sprinklers.

Interior Protection
Non-Sprinklered Building

Calculate all sprinklers on the most demanding side of the glazing assembly within the enclosure.

Exterior Exposure Protection

Calculate all sprinklers controlled by the deluge valve using the design requirements of NFPA.

Duration of Water Supply

Duration of water supply must comply with requirements of NFPA. If window sprinklers are used to provide the equivalency of a fire rating, the water supply must be capable of supplying water for the required rating period.

Minimum Flow per Sprinkler

20 GPM (75,7 LPM) for sprinkler spacing of 6 ft to 8 ft (1,83 m to 2,44 m) or 15 GPM (56,8 LPM) for sprinkler spacing less than 6 ft (1,83 m).

Maximum Pressure per Sprinkler

- Horizontal Sidewall: 70 psi (4,83 bar)*

* The 70 psi is only for cold solder purposes. If there is a baffle or a mullion of sufficient depth to act as a baffle, separating the sprinklers, the maximum pressure is 175 psi (12,07 bar).

- Vertical Sidewall: 175 psi (12,07 bar)

When acceptable to the Authority Having Jurisdiction the Model WS Specific Application Window Sprinklers may be used in either a sprinklered or unsprinklered building to protect nonoperable window openings that are in an interior fire separation, the window sprinklers are installed on both sides of the window in the fire separation.

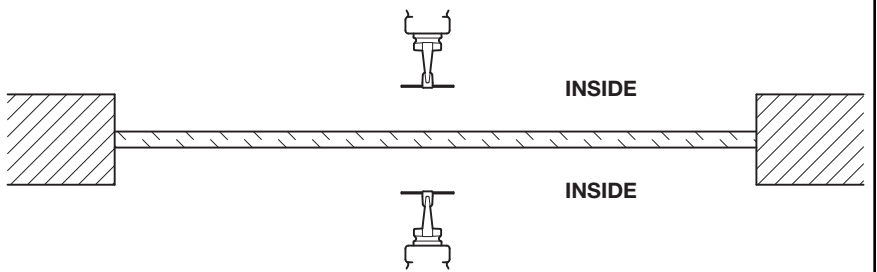

FIGURE 3A-1 – INTERIOR FIRE SEPARATION

When acceptable to the Authority Having Jurisdiction the Model WS Specific Application Window Sprinklers may be used in either a sprinklered or unsprinklered building to protect nonoperable window openings that are part of a fire separation provided in jurisdictions where exterior spatial separation is defined as protecting an adjacent building from a fire in your building, window sprinklers are installed on the interior side of the glass.

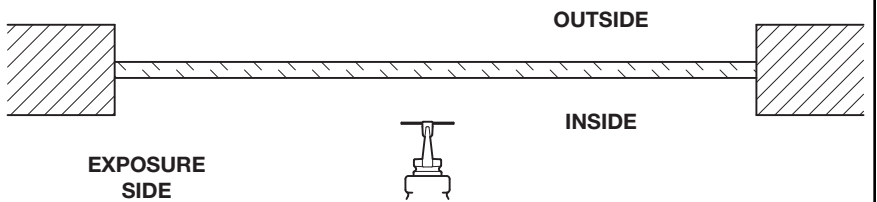

FIGURE 3A-2 - EXTERIOR FIRE SEPARATION - SPRINKLERS INSIDE

When acceptable to the Authority Having Jurisdiction the Model WS Specific Application Window Sprinklers may be used in either a sprinklered or unsprinklered building to protect nonoperable window openings that are part of a fire separation provided in jurisdictions where exterior spatial separation is defined as protecting your building from a fire in an adjacent building, open window sprinklers are installed on the exterior side of the glass.

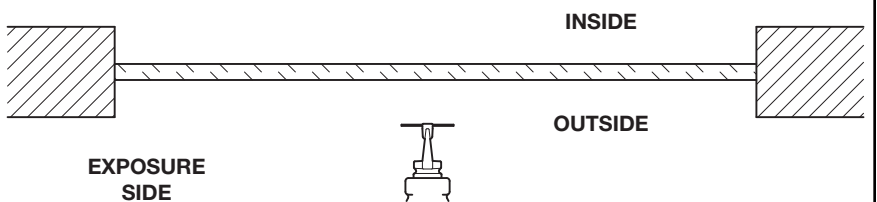

FIGURE 3A-3 - EXTERIOR FIRE SEPARATION - SPRINKLERS OUTSIDE

**FIGURE 3A (A-1 TO A-3)
 TYPICAL NON-OPERABLE WINDOW OPENINGS**

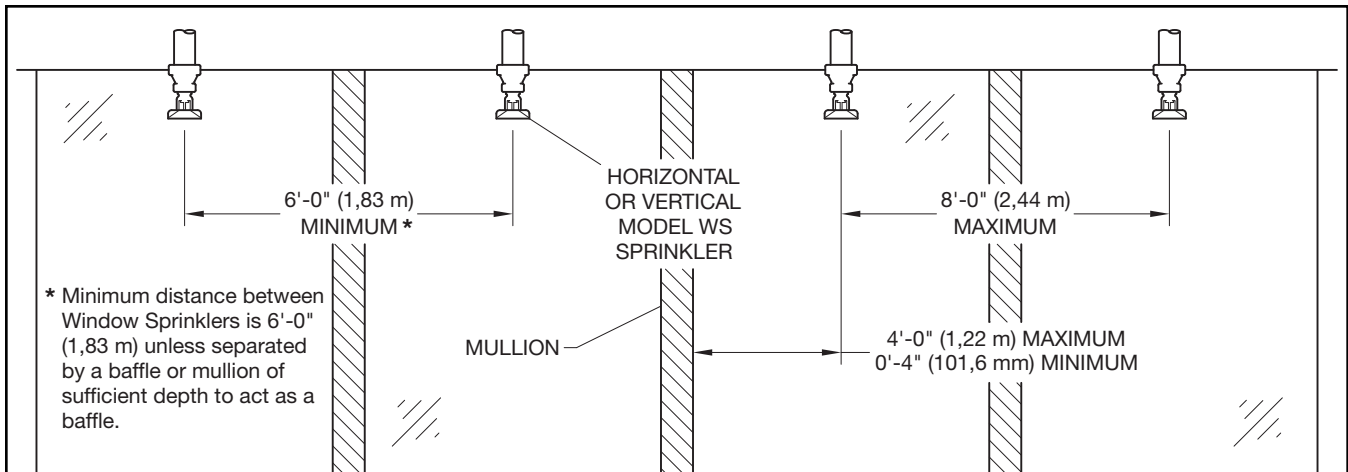

FIGURE 3B-1 - MULTIPLE WINDOWS SEPARATED BY MULLIONS

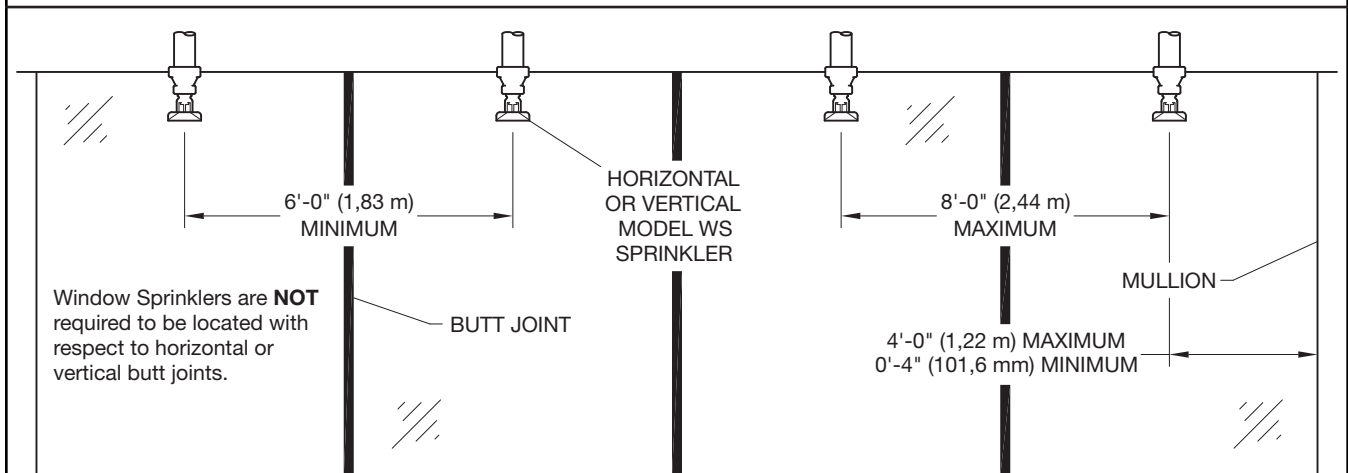

FIGURE 3B-2 - MULTIPLE WINDOWS SEPARATED BY BUTT JOINTS

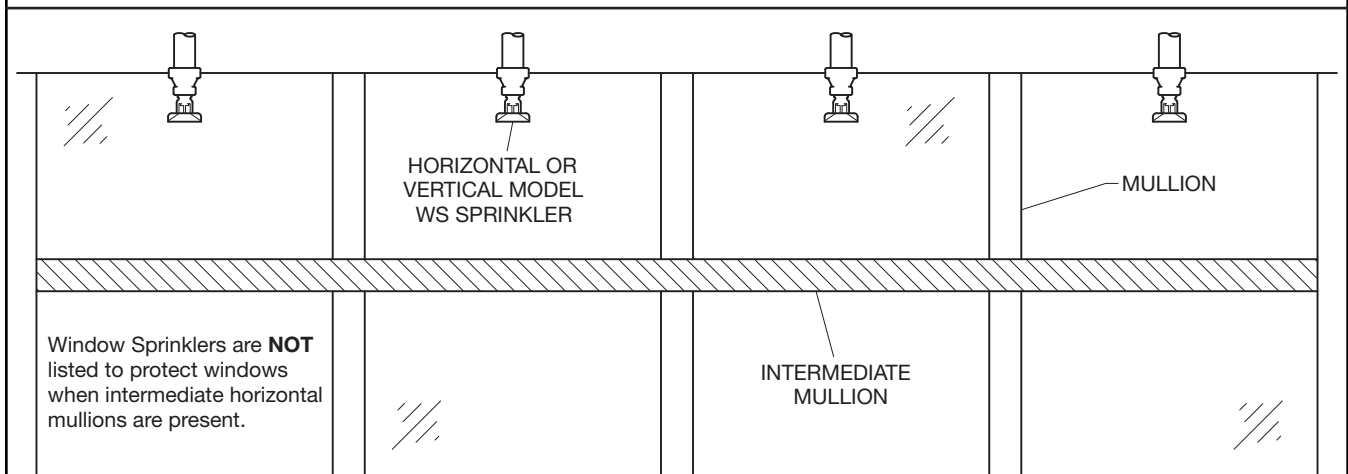
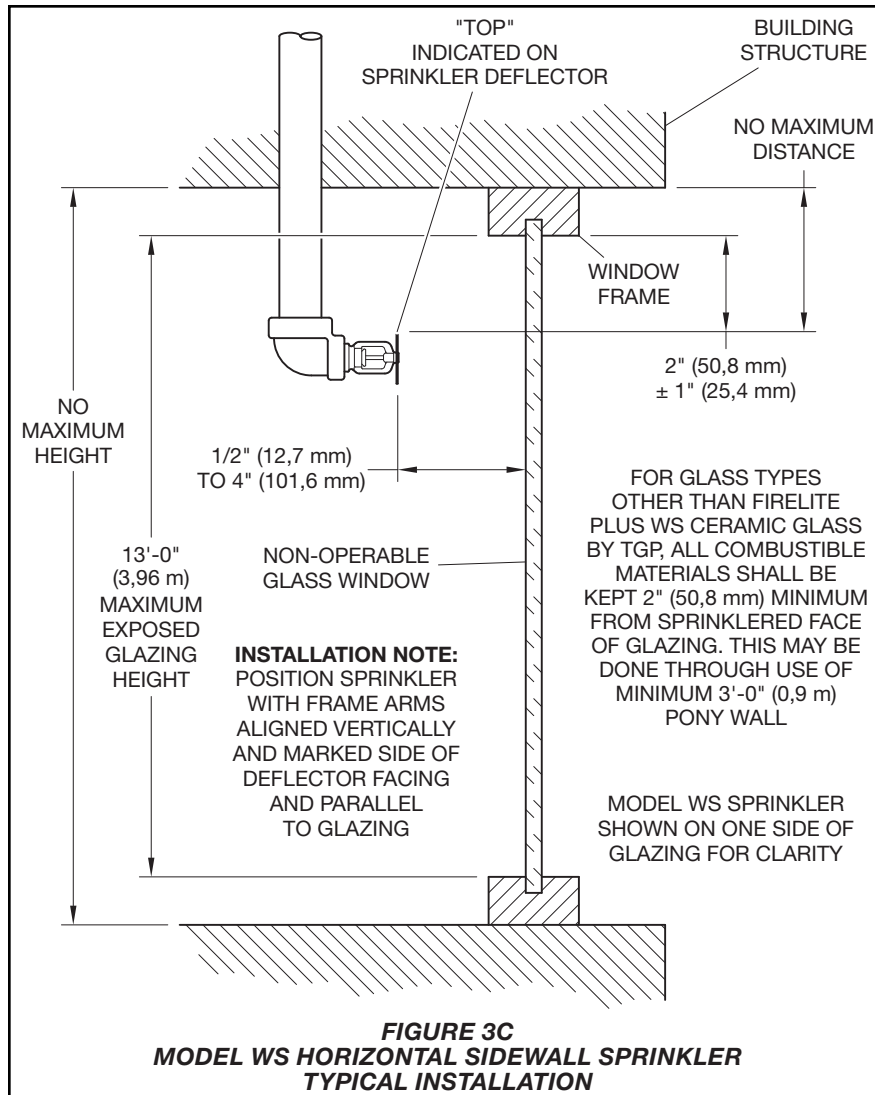

FIGURE 3B-3 - WINDOWS WITH HORIZONTAL MULLIONS

**FIGURE 3B (B-1 TO B-3)
WINDOW MULLIONS AND BUTT JOINTS**



Installation

The TYCO Model WS Specific Application Window Sprinklers must be installed in accordance with this section.

General Instructions

Do not install any bulb-type sprinkler if the bulb is cracked or there is a loss of liquid from the bulb. With the sprinkler held horizontally, a small air bubble should be present. The diameter of the air bubble is approximately 1/16 in. (1,6 mm).

A leak-tight 1/2 in. NPT sprinkler joint should be obtained by applying a minimum-to-maximum torque of 7 to 14 ft-lb (9,5 to 19,0 N-m). Higher levels of torque may distort the sprinkler inlet with consequent leakage or impairment of the sprinkler.

Step 1. Install the pendent vertical sidewall sprinkler only in the pendent position with the center-line of the sprinkler parallel to the glass surface. Orient the sprinkler so that the direction of flow indicated on the sprinkler deflector is facing the window.

Step 2. Install the horizontal sidewall sprinkler only in the horizontal position with the center-line of the sprinkler perpendicular to the glass surface. Orient the sprinkler so that the word "Top" indicated on the sprinkler deflector is facing the top of window frame.

Step 3. With pipe-thread sealant applied to the pipe threads, hand-tighten the sprinkler into the sprinkler fitting.

Step 4. With reference to Figures 1 or 2, apply End A of W-Type 20 Sprinkler Wrench only (Figure 4) to the sprinkler wrench flats and tighten the sprinkler into the sprinkler fitting.

Care and Maintenance

The TYCO Model WS Specific Application Window Sprinklers must be maintained and serviced in accordance with this section.

Before closing a fire protection system main control valve for maintenance work on the fire protection system that it controls, obtain permission to shut down the affected fire protection systems from the proper authorities and notify all personnel who may be affected by this action.

Sprinklers which are found to be leaking or exhibiting visible signs of corrosion must be replaced.

Automatic sprinklers must never be painted, plated, coated, or otherwise altered after leaving the factory. Modified sprinklers must be replaced. Sprinklers that have been exposed to corrosive products of combustion, but have not operated, should be replaced if they cannot be completely cleaned by wiping the sprinkler with a cloth or by brushing it with a soft bristle brush.

Care must be exercised to avoid damage to the sprinklers - before, during, and after installation. Sprinklers damaged by dropping, striking, wrench twist/slippage, or the like, must be replaced. Also, replace any sprinkler that has a cracked bulb or that has lost liquid from its bulb. Refer to the Installation section for additional information.

The owner is responsible for the inspection, testing, and maintenance of their fire protection system and devices in compliance with this document, as well as with the applicable standards recognized by the Approval agency (e.g., NFPA 25), in addition to the standards of any authorities having jurisdiction. Contact the installing contractor or product manufacturer regarding any questions.

Automatic sprinkler systems are recommended to be inspected, tested, and maintained by a qualified Inspection Service in accordance with local requirements and/or national codes.

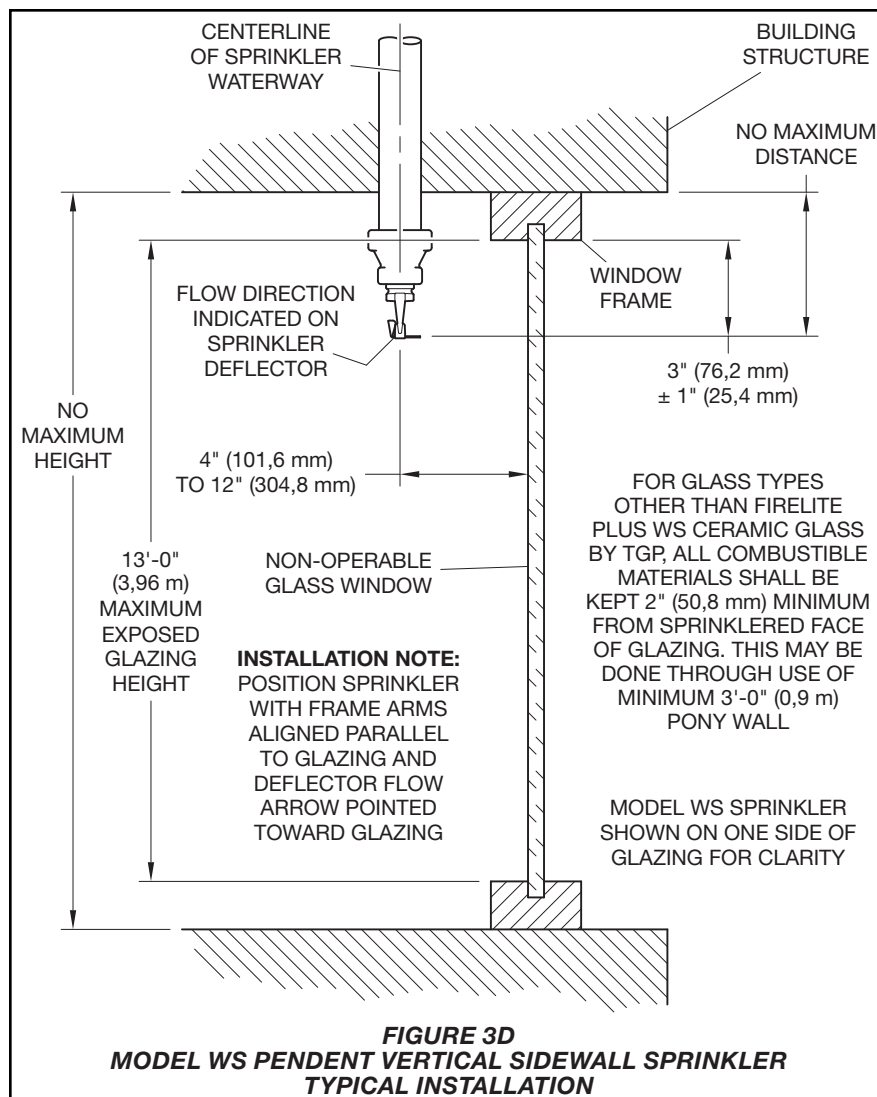

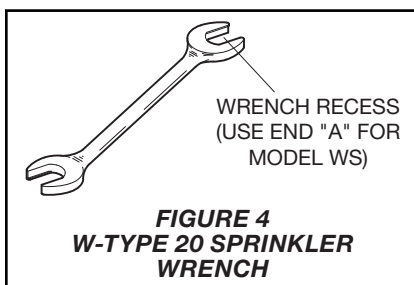
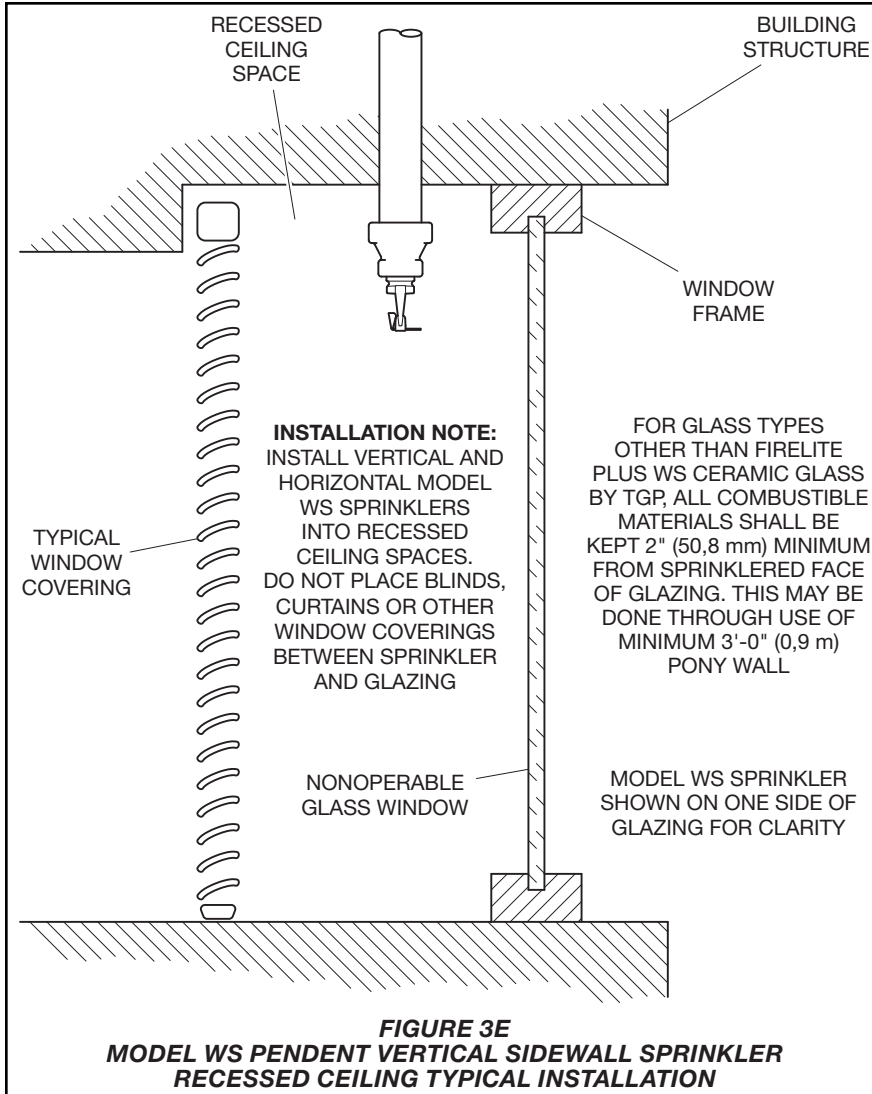

Ordering Procedure

Contact your local distributor for availability. When placing an order, indicate the full product name and Part Number (P/N).

Model WS HSW Window Sprinkler with NPT Thread

Specify: Model WS Specific Application Window Sprinkler TY3388, Horizontal Sidewall, with (specify) temperature rating, (specify) finish, and P/N (specify):

155 °F (68 °C)	
Natural Brass	50-305-1-155
Signal White (RAL9003)	
Polyester	50-305-4-155
Jet Black (RAL9005)	
Polyester	50-305-5-155
Chrome Plated	50-305-9-155
200 °F (93 °C)	
Natural Brass	50-305-1-200
Signal White (RAL9003)	
Polyester	50-305-4-200
Jet Black (RAL9005)	
Polyester	50-305-5-200
Chrome Plated	50-305-9-200

Model WS Pendant Vertical Sidewall Window Sprinkler with NPT Thread

Specify: Model WS Specific Application Window Sprinkler TY3488, Pendant Vertical Sidewall, with (specify) temperature rating, (specify) finish, and P/N (specify):

155 °F (68 °C)	
Natural Brass	50-304-1-155
Signal White (RAL9003)	
Polyester	50-304-4-155
Jet Black (RAL9005)	
Polyester	50-304-5-155
Chrome Plated	50-304-9-155
200 °F (93 °C)	
Natural Brass	50-304-1-200
Signal White (RAL9003)	
Polyester	50-304-4-200
Jet Black (RAL9005)	
Polyester	50-304-5-200
Chrome Plated	50-304-9-200

Sprinkler Wrench

Specify: W-Type 20 Sprinkler Wrench, P/N 56-000-1-106