



Series DS-1 Stainless Steel Dry-Type Sprinklers 5.6K Pendent, HSW, and Extended Coverage HSW Standard and Quick Response

General Description

TYCO Series DS-1 Stainless Steel Dry-Type Sprinklers, 5.6K Pendent, Horizontal Sidewall (HSW), and Extended Coverage HSW, Standard (5 mm bulb) and Quick (3 mm bulb) Response are the first stainless steel dry-type sprinklers to be listed by UL and C-UL. With a K-factor of 5.6, these corrosion-resistant automatic sprinklers can be used in wet-pipe, dry-pipe, or preaction systems.

These pendent and horizontal sidewall sprinklers are available in a variety of configurations to suit coverage type and thermal sensitivity. Refer to the Sprinkler Identification Numbers (SINs) section for details.

Series DS-1 Stainless Steel Dry-Type Sprinklers are typically used:

- where corrosive atmospheres exist (e.g., salt-water areas, parking garages, chemical storage areas, mechanical rooms, industrial manufacturing sites, and software chip washing facilities)
- on dry-pipe systems exposed to freezing temperatures (e.g., sprinkler drops from unheated portions of buildings)

- with pipe connections exposed to freezing temperatures (e.g., sprinkler drops from wet-pipe systems into freezers or horizontal piping extensions to protect unheated areas)
- in systems that are seasonably drained to avoid freezing (e.g., vacation areas)

The stainless steel construction of these sprinklers extends the life of a sprinkler beyond that of traditional copper alloy sprinklers exposed to corrosive atmospheres. Although corrosion-resistant sprinklers have passed the standard corrosion tests of the applicable approval agencies, the testing is not representative of all possible corrosive atmospheres.

Consequently, it is necessary that the end user be consulted with respect to the suitability of this alternate material of construction for any given corrosive environment. As a minimum, consider the following criteria:

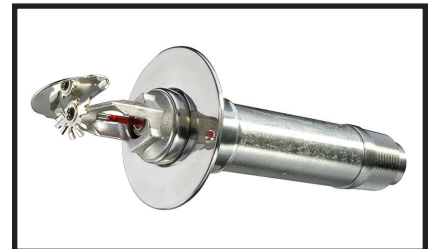
- ambient temperature
- concentration of chemicals
- humidity
- gas/chemical velocity
- corrosive nature of the chemical to which the sprinklers are exposed

Stainless Steel Pendent Dry-Type Sprinklers

The pendent sprinklers are provided with stainless steel escutcheons that allow vertical adjustment during installation. This adjustment provides a measure of flexibility in determining the length of fixed piping to cut for sprinkler drops.

Stainless Steel Sidewall Dry-Type Sprinklers

The horizontal sidewall sprinklers are designed for installation along a wall or side of a soffit and just beneath a smooth ceiling. Sidewall sprinklers are commonly used instead of pendent sprinklers due to aesthetics or building construction considerations where piping along the ceiling is not desirable.



NOTICE

The Series DS-1 Stainless Steel Dry-Type Sprinklers described herein must be installed and maintained in compliance with this document, as well as with the applicable standards of the NATIONAL FIRE PROTECTION ASSOCIATION (NFPA), in addition to the standards of any authorities having jurisdiction. Failure to do so may impair the performance of these devices.

The owner is responsible for maintaining their fire protection system and devices in proper operating condition. Contact the installing contractor or product manufacturer with any questions.

The Series DS-1 Stainless Steel Dry-Type Sprinklers must only be installed in fittings that meet the requirements of the Design Criteria section.

IMPORTANT

Refer to Technical Data Sheet TFP2300 for warnings pertaining to regulatory and health information.

Always refer to Technical Data Sheet TFP700 for the "INSTALLER WARNING" that provides cautions with respect to handling and installation of sprinkler systems and components. Improper handling and installation can permanently damage a sprinkler system or its components and cause the sprinkler to fail to operate in a fire situation or cause it to operate prematurely.

Temperature Rating	Bulb Color Code	Standard Coverage				Extended Coverage Horizontal Sidewall
		Pendent		Horizontal Sidewall		
		TY3230 (3 mm Bulb) with Standard Escutcheon (Figure 10) with Recessed Escutcheon ^(a) (Figure 11) with Deep Escutcheon (Figure 12) without Escutcheon (Figure 13)	TY3250 (5 mm Bulb) with Standard* Escutcheon (Figure 10) with Recessed Escutcheon ^(a) (Figure 11) with Deep* Escutcheon (Figure 12) without* Escutcheon (Figure 13)	TY3337 (3 mm Bulb) ^(b) with Standard Escutcheon (Figure 14) with Deep Escutcheon (Figure 15) without Escutcheon (Figure 16)	TY3357 (5 mm Bulb) ^(b) with Standard Escutcheon (Figure 14) with Deep Escutcheon (Figure 15) without Escutcheon (Figure 16)	TY3339 (3 mm Bulb) ^(c) with Standard Escutcheon (Figure 17)
135°F (57°C)	Orange	1, 2	1, 2	1**, 2**	1**, 2**	1***, 2***
155°F (68°C)	Red	1, 2	1, 2, 3*	1**, 2**	1**, 2**	1***, 2***
175°F (79°C)	Yellow	1, 2	1, 2	1**, 2**	1**, 2**	N/A
200°F (93°C)	Green	1, 2	1, 2, 3*	1**, 2**	1**, 2**	N/A
286°F (141°C)	Blue	1, 2	1, 2, 3*	1**, 2**	1**, 2**	N/A
360°F (182°C)	Mauve	N/A	1, 2	N/A	1**, 2**	N/A

Notes:

- Listed by Underwriters Laboratories, Inc. (UL). Stainless steel sprinklers noted to be UL Listed are listed as Corrosion Resistant Sprinklers. Maximum order lengths are described in Figures 10 through 17.
 - Listed by Underwriters Laboratories for use in Canada (C-UL). Stainless steel sprinklers noted to be C-UL Listed are listed as Corrosion Resistant Sprinklers. Maximum order lengths are described in Figures 10 through 17.
 - Loss Prevention Certification Board (LPCB) approval and CE conformity apply to these temperature ratings only.
 - This configuration is applicable only up to 286°F (141°C).
 - To meet the deflector-to-ceiling distance of 4 to 12 inches (100 to 300 mm) for the standard coverage horizontal sidewall, the centerline of the sprinkler waterway must be 4-5/16 to 12-5/16 inches below the ceiling.
 - To meet the deflector-to-ceiling distance of 4 to 12 in. (100 to 300 mm) for the extended coverage horizontal sidewall, the centerline of the sprinkler waterway must be 4-7/16 to 12-7/16 inches below the ceiling.
- * LPCB approval and CE conformity apply to only these configurations for TY3250 with only these indicated temperatures.
 ** Light and Ordinary Hazard Occupancies only.
 *** Light Hazard Occupancies only.
 N/A – Not Applicable

TABLE A
SERIES DS-1 STAINLESS STEEL DRY-TYPE
PENDENT AND HORIZONTAL SIDEWALL
STANDARD AND EXTENDED COVERAGE SPRINKLERS
LABORATORY LISTINGS AND APPROVALS

APPLICATION ⁽¹⁾	Coverage ⁽²⁾ W x L, ft x ft (m x m)	Minimum Flow, gpm (lpm)	Minimum Pressure, psi (bar)	Temperature Rating	Top of Deflector-to-Ceiling Distance ⁽²⁾
TY3339 (3 mm Bulb) For Quick Response, Light Hazard, Extended Coverage per NFPA 13	16 x 16 (4,9 x 4,9)	26 (98)	21.6 (1,49)	135 °F (57 °C) and 155 °F (68 °C)	4 in. (100 mm) to 12 in. (300 mm)
	16 x 18 (4,9 x 5,5)	29 (110)	26.8 (1,85)		
	16 x 20 (4,9 x 6,1)	32 (121)	32.7 (2,25)		
	18 x 16 (5,5 x 4,9)	29 (110)	26.8 (1,85)		

Notes:

- These sprinklers are Listed by UL and C-UL. Stainless steel sprinklers noted to be UL and C-UL Listed are listed as Corrosion Resistant Sprinklers.
- The minimum allowable spacing between sprinklers to prevent cold soldering is 14 ft (4,3 m).

TABLE B
SERIES DS-1 STAINLESS STEEL DRY-TYPE
HORIZONTAL SIDEWALL EXTENDED COVERAGE SPRINKLERS
UL AND C-UL INSTALLATION CRITERIA

Sprinkler Identification Numbers (SINs)

Standard Coverage Pendent

- TY3230 – 3 mm Bulb
- TY3250 – 5 mm Bulb

Standard Coverage Horizontal Sidewall

- TY3337 – 3 mm Bulb
- TY3357 – 5 mm Bulb

Extended Coverage Horizontal Sidewall

- TY3339 – 3 mm Bulb

Technical Data

Approvals

UL and C-UL Listed
LPCB Approved: Ref. No. 094a/12
CE Certified: EN 12259-1

(Refer to Tables A and B for details)

Maximum Working Pressure
175 psi (12,1 bar)

Inlet Thread Connections
1-Inch NPT or
ISO 7-R 1

Discharge Coefficient
 $K=5.6 \text{ GPM/psi}^{1/2}$ (80,6 LPM/bar^{1/2})

Temperature Ratings
Refer to Tables A and B

Finishes

Sprinkler: Stainless Steel
Escutcheon: Stainless Steel

Physical Characteristics

With the exceptions of the bulb, the Insert, the Deflector, and the Sealing Assembly, all components of the Series DS-1 Stainless Steel Dry-Type Sprinkler are constructed with Type 316 Stainless Steel.

- The bulb is glass.
- The Insert is 300 Series Stainless Steel.
- The Deflector is Type 316L Stainless Steel.

The Sealing Assembly consists of a Disc Spring that is sealed on both its inside and outside faces with a TEFLON gasket. The Disc Spring is 1/2 Hard Beryllium Nickel. Refer to Figures 1 through 3 for component assemblies.

Operation

When TYCO Series DS-1 Stainless Steel Dry-Type Sprinklers, 5.6K Pendent, Horizontal Sidewall (HSW), and Extended Coverage HSW, Standard (5 mm bulb) and Quick (3 mm bulb) Response are in service, water is prevented from entering the assembly by the Plug with Sealing Assembly in the Inlet of the sprinkler. Refer to Figures 1 through 3.

The glass bulb contains a fluid that expands when exposed to heat. When the rated temperature is reached, the fluid expands sufficiently to shatter the glass bulb then release the Bulb Seat.

The compressed Spring is then able to expand and push the Water Tube as well as the Guide Tube outward. This outward action simultaneously pulls inward on the Yoke, withdrawing the Plug with Sealing Assembly from the Inlet and allowing the sprinkler to activate and flow water effectively.

Design Criteria

TYCO Series DS-1 Stainless Steel Dry-Type Sprinklers, 5.6K Pendent, Horizontal Sidewall (HSW), and Extended Coverage HSW, Standard (5 mm bulb) and Quick (3 mm bulb) Response are intended for use in fire sprinkler systems designed in accordance with the standard installation rules recognized by the applicable Listing or Approval agency (e.g., UL Listing is based on NFPA 13 requirements).

For more information on LPCB Approval, contact Johnson Controls at the following office:

Kopersteden 1
7547 TJ Enschede
The Netherlands
Tel: +31-(0)53-428-4444
Fax: +31-(0)53-428-3377

The Series DS-1 Stainless Steel Extended Coverage Sprinklers are intended for use in fire sprinkler systems designed in accordance with extended coverage installation guidelines provided by NFPA 13 and the installation criteria provided by Table B.

Sprinkler Fittings

Install the 1 inch NPT Series DS-1 Stainless Steel Dry-Type Sprinkler in the 1 inch NPT outlet or run of one of the following fittings:

- malleable or ductile iron threaded tee fittings that meet the dimensional requirements of ANSI B16.3 (Class 150)
- cast iron threaded tee fittings that meet the dimensional requirements of ANSI B16.4 (Class 125)
- cast bronze threaded tee fittings that meet the dimensional requirements of ANSI B16.15 (Class 125)
- stainless steel threaded tee fittings that meet the dimensional requirements of MSS SP-114.

Do not install the Series DS-1 Stainless Steel Dry-Type Sprinklers into elbow fittings. The inlet of the sprinkler can contact the interior of the elbow, potentially damaging the Inlet seal.

The unused outlet of the threaded tee is plugged as shown in Figures 4 and 5.

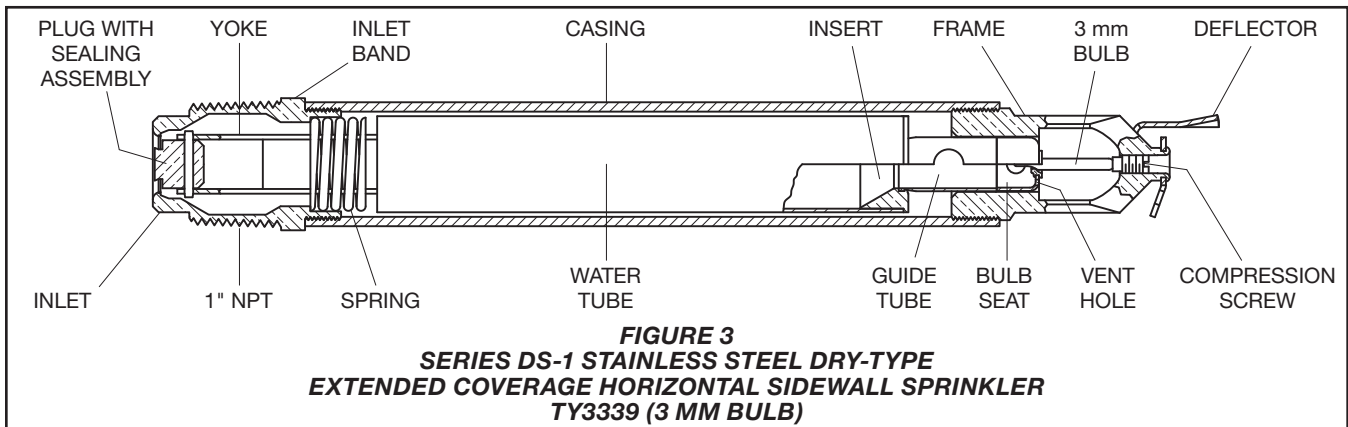
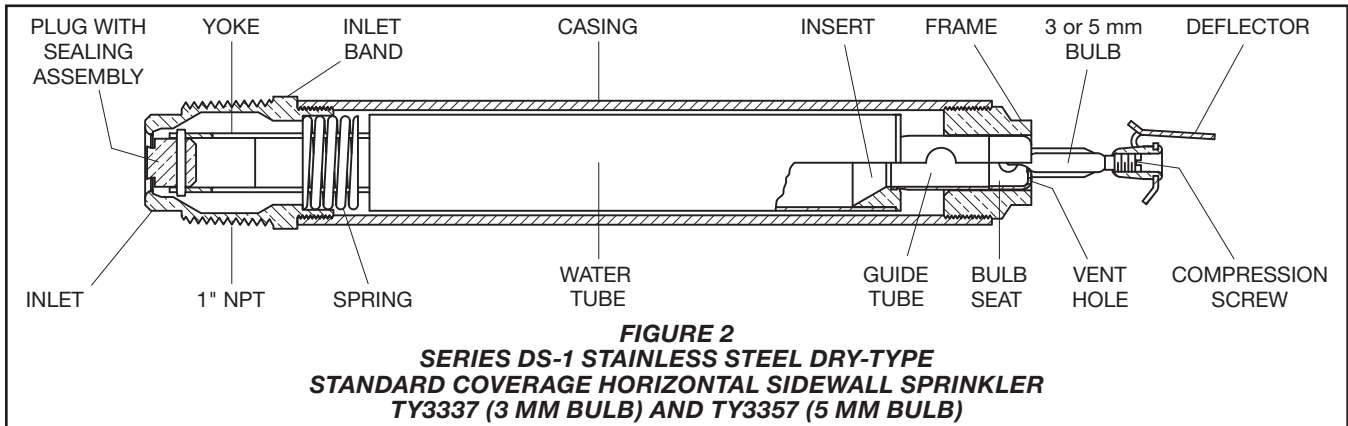
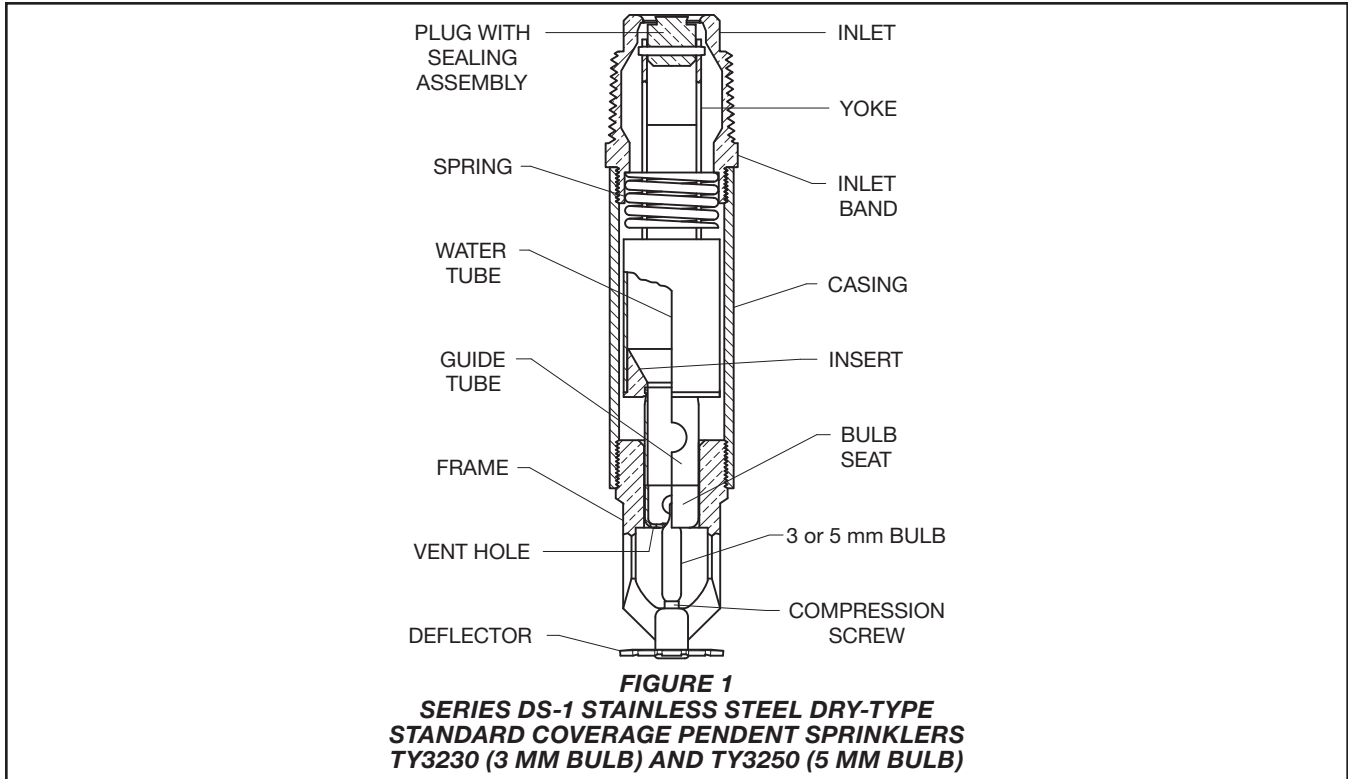
You can also install the Series DS-1 Sprinklers in the 1 Inch NPT outlet of a GRINNELL Figure 730 Mechanical Tee. However, the use of the Figure 730 Tee for this arrangement is limited to wet-pipe systems.

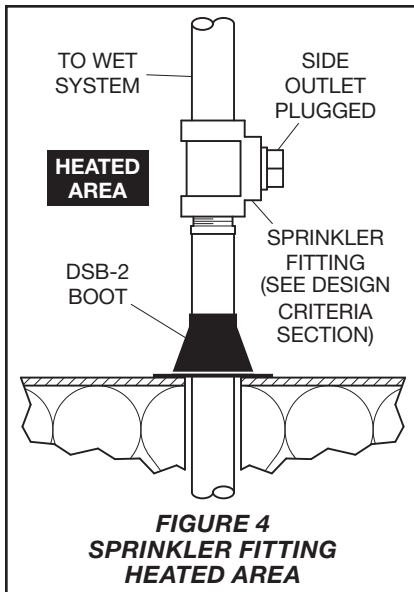
The configuration shown in Figure 4 is only applicable for wet-pipe systems where the sprinkler fitting and water-filled pipe above the sprinkler fitting are not subject to freezing and where the length of the Stainless Steel Dry-Type Sprinkler has the minimum exposure length depicted in Figure 6. Refer to the Exposure Length section.

For wet-pipe system installations of the 1 Inch NPT Series DS-1 Stainless Steel Dry-Type Sprinklers connected to CPVC piping, use only the following TYCO CPVC fittings:

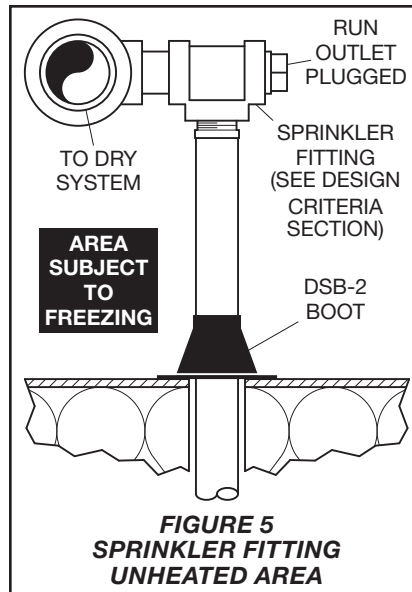
- 1 in. x 1 in. NPT Female Adapter (P/N 80145)
- 1 in. x 1 in. x 1 in. NPT Sprinkler Head Adapter Tee (P/N 80249)

For dry-pipe system installations, use only the side outlet of maximum 2-1/2 inch reducing tee when locating the Series DS-1 Stainless Steel Dry-Type Sprinklers directly below the branch line. Otherwise, use the configuration shown in Figure 5 to assure complete water drainage from above the Series DS-1 Stainless Steel Dry-Type Sprinklers and the branchline. Failure to do so may result in pipe freezing and water damage.

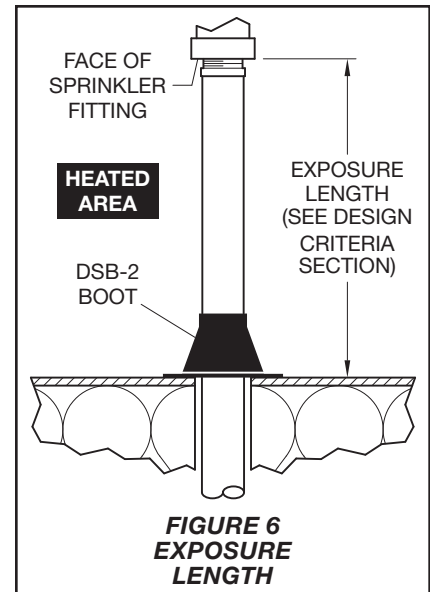




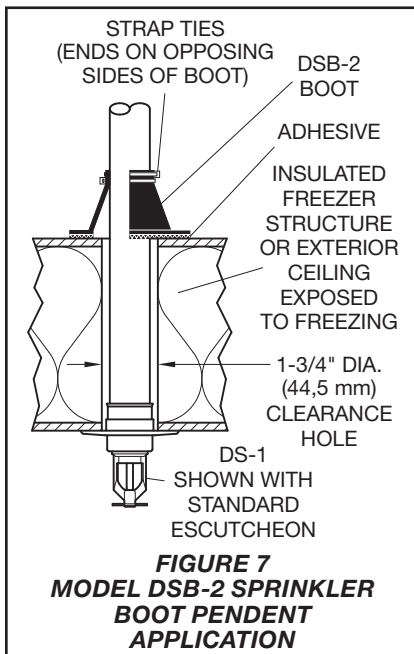
**FIGURE 4
SPRINKLER FITTING
HEATED AREA**



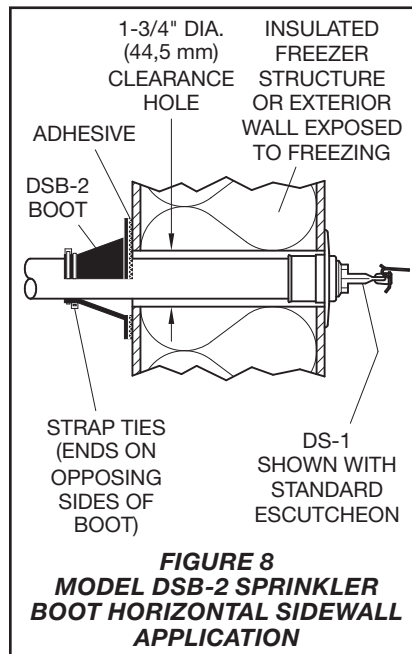
**FIGURE 5
SPRINKLER FITTING
UNHEATED AREA**



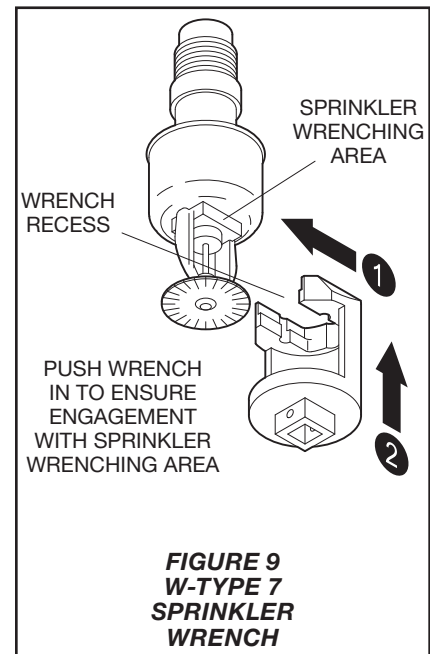
**FIGURE 6
EXPOSURE
LENGTH**



**FIGURE 7
MODEL DSB-2 SPRINKLER
BOOT PENDENT
APPLICATION**



**FIGURE 8
MODEL DSB-2 SPRINKLER
BOOT HORIZONTAL SIDEWALL
APPLICATION**



**FIGURE 9
W-TYPE 7
SPRINKLER
WRENCH**

NOTICE

Do not install the Series DS-1 Stainless Steel Dry-Type Sprinklers into any other type fitting. Failure to use the appropriate fitting can result in one of the following:

- failure of the sprinkler to operate properly due to formation of ice over the Inlet Plug or binding of the Inlet Plug
- insufficient engagement of the Inlet pipe threads with consequent leakage

Drainage

In accordance with the minimum requirements of the NATIONAL FIRE PROTECTION ASSOCIATION for dry-pipe sprinkler systems, pitch branch, cross, and feed main piping connected to Stainless Steel Dry-Type Sprinklers and subject to freezing temperatures to allow proper drainage.

Exposure Length

When using Stainless Steel Dry-Type Sprinklers in wet-pipe sprinkler systems protecting areas subject to freezing temperatures, use Table C to determine a sprinkler's appropriate exposed barrel length to prevent water from freezing in the connecting pipes due to conduction. The exposed barrel length measurement must be taken from the face of the sprinkler fitting to

the surface of the structure or insulation that is exposed to the heated area. Refer to Figure 6 for an example.

Clearance Space

NFPA 13 requires a sealed clearance space around the sprinkler barrel of dry sprinklers that are connected to wet-pipe sprinkler systems protecting insulated freezer structures. The use of the Model DSB-2 Dry Sprinkler Boot, described in technical data sheet TFP591 and illustrated in Figures 7 and 8, meets this NFPA 13 requirement.

Ambient Temperature Exposed to Discharge End of Sprinkler	Temperatures for Heated Area ^(a)		
	40°F (4°C)	50°F (10°C)	60°F (16°C)
	Minimum Exposed Barrel Length ^(b) , Inches (mm)		
40°F (4°C)	0	0	0
30°F (-1°C)	0	0	0
20°F (-7°C)	4 (100)	0	0
10°F (-12°C)	8 (200)	1 (25)	0
0°F (-18°C)	12 (305)	3 (75)	0
-10°F (-23°C)	14 (355)	4 (100)	1 (25)
-20°F (-29°C)	14 (355)	6 (150)	3 (75)
-30°F (-34°C)	16 (405)	8 (200)	4 (100)
-40°F (-40°C)	18 (455)	8 (200)	4 (100)
-50°F (-46°C)	20 (510)	10 (255)	6 (150)
-60°F (-51°C)	20 (510)	10 (255)	6 (150)

Notes:
a. For protected area temperatures that occur between values listed above, use the next cooler temperature.
b. These lengths are inclusive of wind velocities up to 30 mph (18,6 kph).

TABLE C
EXPOSED SPRINKLER BARRELS IN WET-PIPE SYSTEMS
MINIMUM RECOMMENDED LENGTHS

Installation

TYCO Series DS-1 Stainless Steel Dry-Type Sprinklers, 5.6K Pendent, Horizontal Sidewall (HSW), and Extended Coverage HSW, Standard (5 mm bulb) and Quick (3 mm bulb) Response must be installed in accordance with this section.

NOTICE

The Series DS-1 must only be installed in fittings that meet the requirements of the Design Criteria section. For other important requirements regarding piping design and sealing of the clearance space around the Sprinkler Casing, refer to the Design Criteria section.

Do not install any bulb type sprinkler if the bulb is cracked or there is a loss of liquid from the bulb. With the sprinkler held horizontally, a small air bubble should be present. The diameter of the air bubble is approximately 1/16 in. (1,6 mm) for the 135°F (57°C) rating to 1/8 in. (3,2 mm) for the 286°F (141°C) rating.

A leak-tight 1 inch NPT sprinkler joint should be obtained by applying a minimum-to-maximum torque of 20 to 30 lb-ft (26,8 to 40,2 N·m). Higher levels of torque can distort the sprinkler Inlet with consequent leakage or impairment of the sprinkler.

Do not attempt to compensate for insufficient adjustment in an Escutcheon Plate by under- or over-tightening the Sprinkler. Re-adjust the position of the sprinkler fitting to suit.

Step 1. Install pendent sprinklers only in the pendent position with the deflector parallel to the ceiling. Install horizontal sidewall sprinklers in the horizontal position with their center-line of waterway perpendicular to the back wall and parallel to the ceiling. Ensure the word "TOP" on the Deflector faces the ceiling.

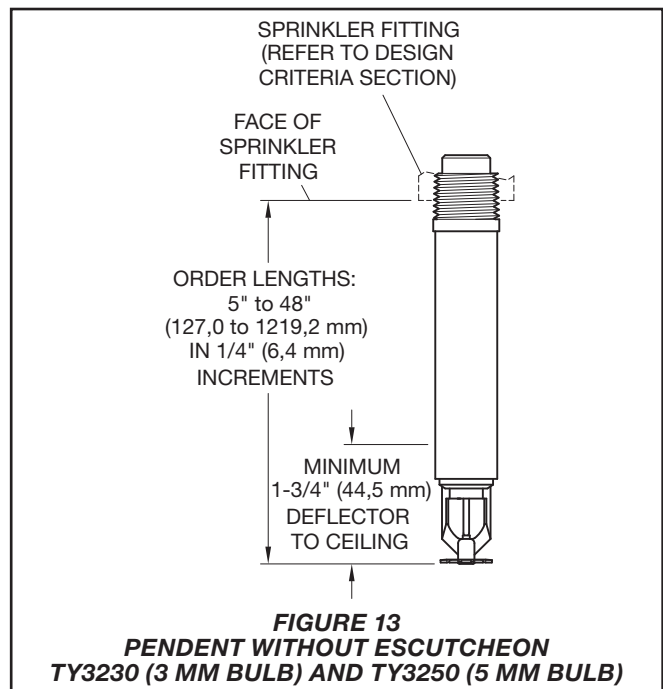
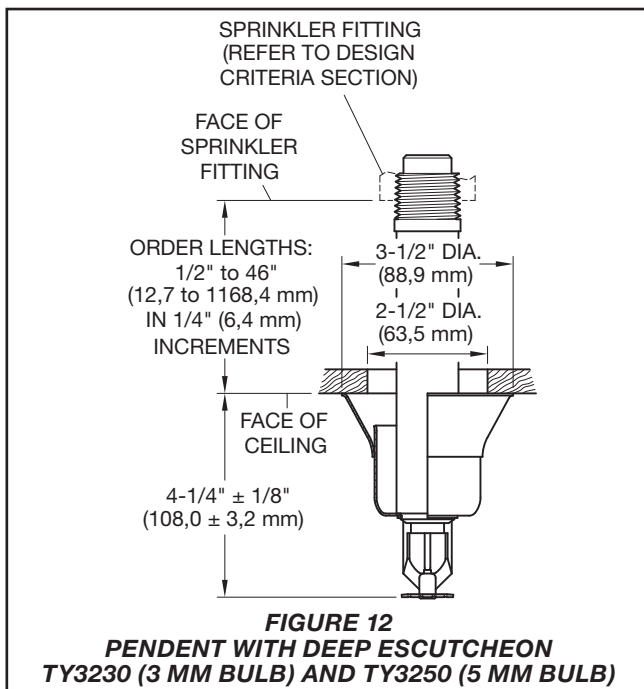
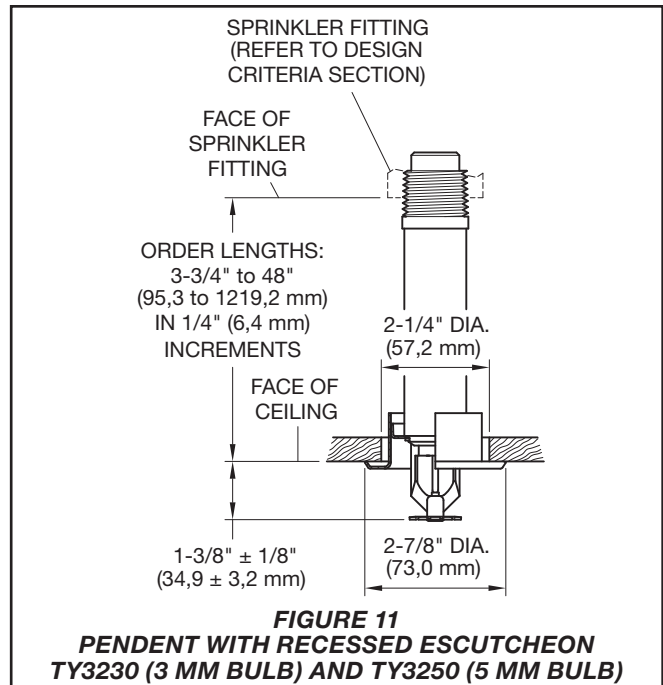
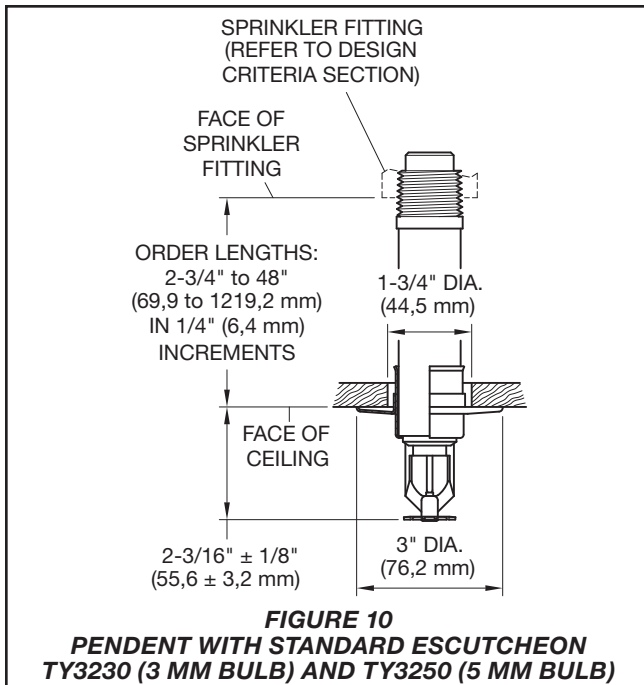
Step 2. With a non-hardening pipe thread sealant such as TEFLON applied to the Inlet threads, hand-tighten the sprinkler into the sprinkler fitting.

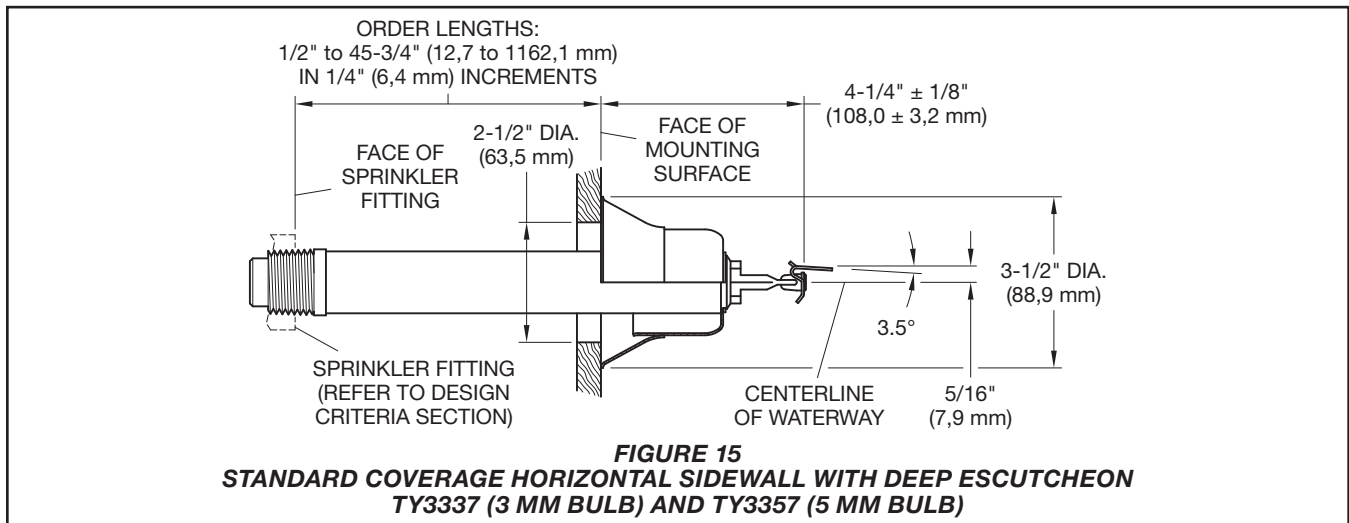
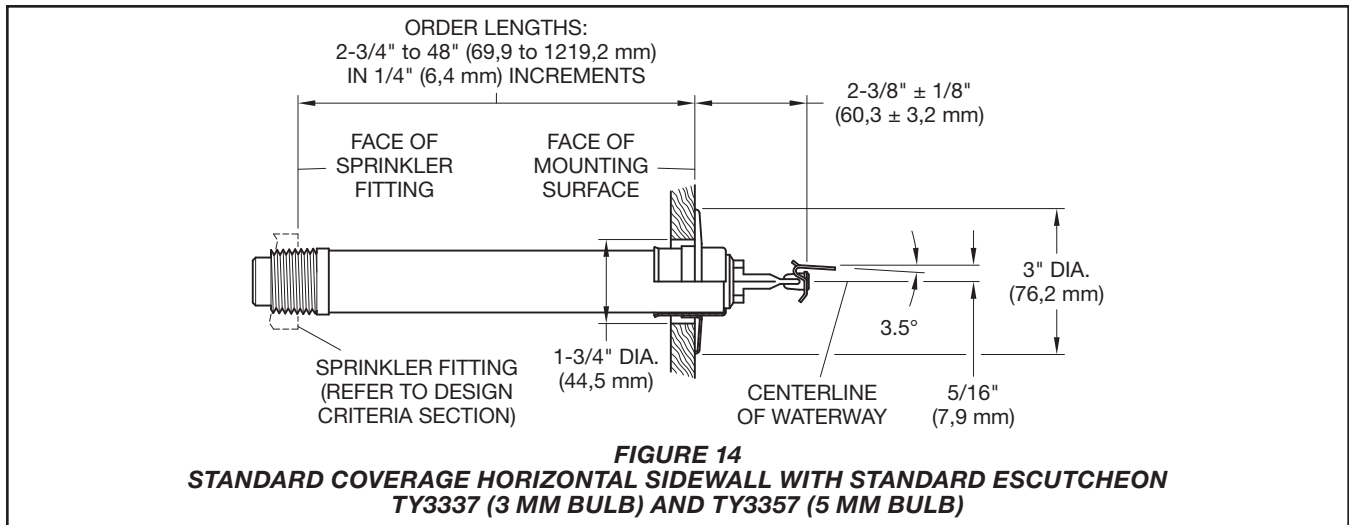
Step 3. Wrench-tighten the sprinkler using a pipe wrench on the Inlet Band or Casing (refer to Figures 1 to 3) or using the W-Type 7 Sprinkler Wrench on the Wrench Flat (refer to Figure 9).

Note: If sprinkler removal becomes necessary, remove the sprinkler using the same wrenching method noted above. Sprinkler removal is easier when a non-hardening sealant was used and torque guidelines were followed. After removal, inspect the sprinkler for damage.

Step 4. After installing the ceiling or wall and applying a ceiling finish, slide on the outer piece of the Escutcheon until it comes in contact with the ceiling or wall. Do not lift the ceiling panel out of its normal position.

When using the Deep Escutcheon, hold the outer piece in contact with the mounting surface (ceiling or wall). Then rotate the inner piece approximately 1/4 turn, with respect to the outer piece, to hold the Deep Escutcheon firmly together.





Care and Maintenance

TYCO Series DS-1 Stainless Steel Dry-Type Sprinklers, 5.6K Pendent, Horizontal Sidewall (HSW), and Extended Coverage HSW, Standard (5 mm bulb) and Quick (3 mm bulb) Response must be maintained and serviced in accordance with this section.

Before closing a fire protection system main control valve for maintenance work on the fire protection system that it controls, obtain permission to shut down the affected fire protection systems from the proper authorities and notify all personnel who may be affected by this action.

Absence of the outer piece of an escutcheon, which is used to cover a clearance hole, can delay sprinkler operation in a fire situation.

A Vent Hole is provided in the Bulb Seat to indicate if the Dry Sprinkler is remaining dry. (Refer to Figures 1 through 3.) Evidence of leakage from the Vent Hole indicates potential leakage past the Inlet seal and the need to remove the sprinkler to determine the cause of leakage; for example, an improper installation or an ice plug. Close the fire protection system control valve and drain the system before removing the sprinkler.

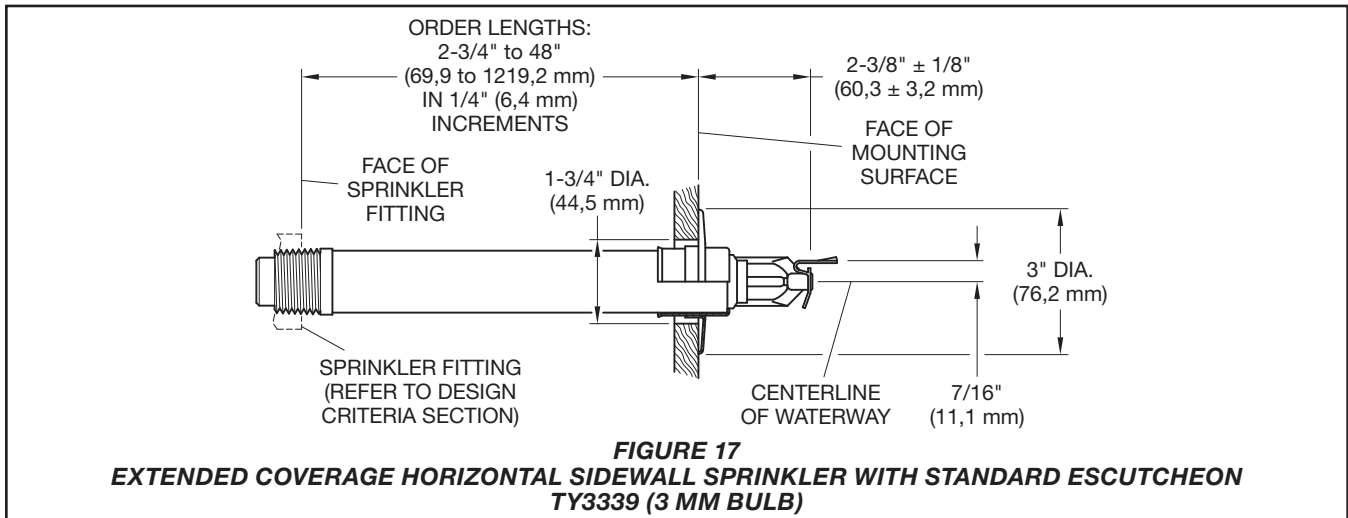
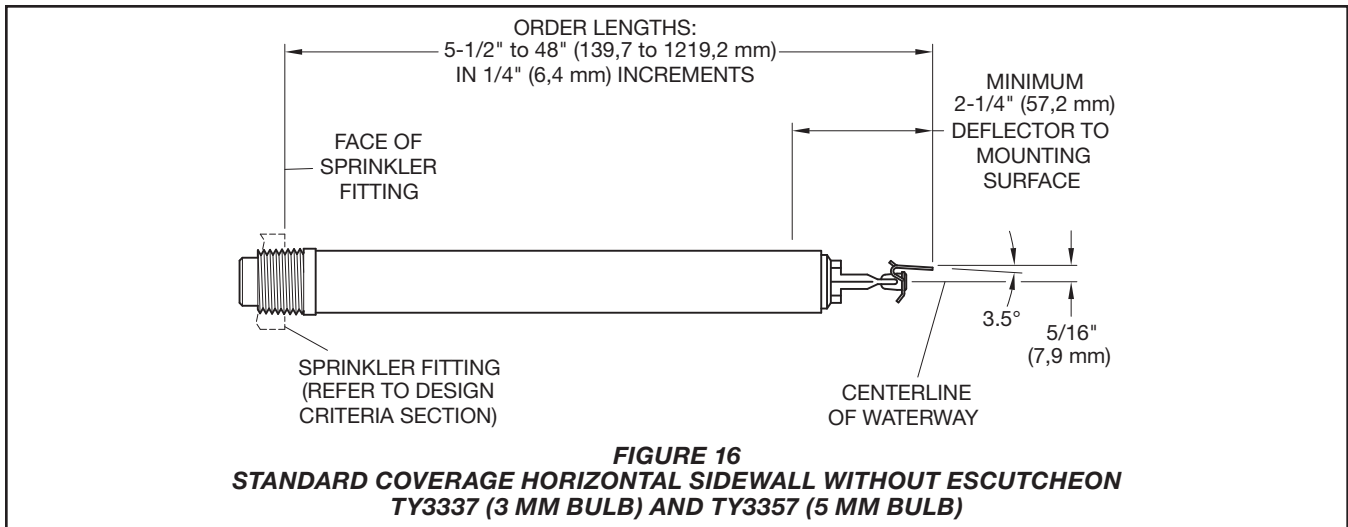
Sprinklers which are found to be leaking or exhibiting visible signs of corrosion must be replaced.

Automatic sprinklers must never be painted, plated, coated, or otherwise altered after leaving the factory. Modified sprinklers must be replaced. Sprinklers that have been exposed to corrosive products of combustion, but have not operated, should be replaced if they cannot be completely cleaned by wiping the sprinkler with a cloth or by brushing it with a soft bristle brush.

Care must be exercised to avoid damage to the sprinklers - before, during, and after installation. Sprinklers damaged by dropping, striking, wrench twist/slippage, or the like, must be replaced. Also, replace any sprinkler that has a cracked bulb or that has lost liquid from its bulb. (Refer to Installation Section.)

The owner is responsible for the inspection, testing, and maintenance of their fire protection system and devices in compliance with this document, as well as with the applicable standards of the NATIONAL FIRE PROTECTION ASSOCIATION (e.g., NFPA 25), in addition to the standards of any other authorities having jurisdiction. Contact the installing contractor or product manufacturer with any questions.

Automatic sprinkler systems are recommended to be inspected, tested, and maintained by a qualified Inspection Service in accordance with local requirements and/or national codes.



and Extended Coverage HSW, Standard (5 mm bulb) and Quick (3 mm bulb) Response, specify the following information:

- SIN
 - Standard Coverage Pendent**
TY3230 – Quick Response
TY3250 – Standard Response
 - Standard Coverage Horizontal Sidewall**
TY3337 – Quick Response
TY3357 – Standard Response

Extended Coverage Horizontal Sidewall
TY3339 – Quick Response

- Order Length:
Dry-Type Sprinklers are furnished based upon Order Length as measured per Figures 10 through 17, as applicable. Measure the required length and then round the measurement to the nearest 1/4 inch increment.

- Inlet Connections:
1 Inch NPT (Standard)
ISO 7-R 1
(For information on ISO Inlet Thread Connections, contact your Johnson Controls Sales Representative.)
- Temperature Rating
(Temperature rating 360°F (182°C) applies to non-recessed sprinkler assemblies.)
- Escutcheon Type, as applicable
- Part Number from Table D

Sprinkler Wrench
Specify W-Type 7 Sprinkler Wrench
P/N 56-850-4-001

Sprinkler Boot
Specify Model DSB-2 Dry Sprinkler Boot, P/N 63-000-0-002

This P/N includes one (1) Boot, two (2) Strap Ties, and 1/3 oz of Adhesive (a sufficient quantity for installing one boot).

Ordering Procedure

Contact your local distributor for availability. When placing an order, indicate the full product description and Part Number (P/N).

Refer to the price list for a complete listing of part numbers. Part numbers are for 1 inch NPT standard order sprinklers. Orders for all other sprinkler assemblies must be accompanied by a complete description.

Stainless Steel Dry-Type Sprinkler
When ordering Series DS-1 Stainless Steel Dry-Type Sprinklers, 5.6K Pendent, Horizontal Sidewall (HSW),

P/N* 60 – XXX – X– XXX

		SIN	ORDER LENGTH EXAMPLES ⁽¹⁾	
11	SS Pendent Quick Response with Standard Escutcheon (1 in. NPT)	TY3230 (Figure 10)	055	5.50 in.
12	SS Pendent Quick Response with Recessed Escutcheon (1 in. NPT)	TY3230 (Figure 11)	082	8.25 in.
13	SS Pendent Quick Response with Deep Escutcheon (1 in. NPT)	TY3230 (Figure 12)	180	18.00 in.
14	SS Pendent Quick Response without Escutcheon (1 in. NPT)	TY3230 (Figure 13)	187	18.75 in.
			372	37.25 in.
			480	48.00 in.
			FINISH	
21	SS Pendent Standard Response with Standard Escutcheon (1 in. NPT)	TY3250 (Figure 10)	6	Stainless Steel for Sprinkler and Escutcheon
22	SS Pendent Standard Response with Recessed Escutcheon (1 in. NPT)	TY3250 (Figure 11)		
23	SS Pendent Standard Response with Deep Escutcheon (1 in. NPT)	TY3250 (Figure 12)		
24	SS Pendent Standard Response without Escutcheon (1 in. NPT)	TY3250 (Figure 13)		
			TEMPERATURE RATING ⁽²⁾⁽³⁾	
15	SS HSW Quick Response Standard Coverage with Standard Escutcheon (1 in. NPT)	TY3337 (Figure 14)	0	135°F (57°C)
16	SS HSW Quick Response Standard Coverage with Deep Escutcheon (1 in. NPT)	TY3337 (Figure 15)	1	155°F (68°C)
17	SS HSW Quick Response Standard Coverage without Escutcheon (1 in. NPT)	TY3337 (Figure 16)	2	175°F (79°C)
			3	200°F (93°C)
			4	286°F (141°C)
			5	360°F (182°C)
25	SS HSW Standard Response Standard Coverage with Standard Escutcheon (1 in. NPT)	TY3357 (Figure 14)		
26	SS HSW Standard Response Standard Coverage with Deep Escutcheon (1 in. NPT)	TY3357 (Figure 15)		
27	SS HSW Standard Response Standard Coverage without Escutcheon (1 in. NPT)	TY3357 (Figure 16)		
18	SS HSW Quick Response Extended Coverage with Standard Escutcheon (1 in. NPT)	TY3339 ⁽³⁾ (Figure 17)		

TABLE D
SERIES DS-1 STAINLESS STEEL DRY-TYPE SPRINKLERS
PART NUMBER SELECTION

Notes:

1. Dry-Type Sprinklers are furnished based upon "Order Length" as measured per Figures 10 through 17 and for each individual sprinkler where it is to be installed. After taking the measurement, round it to the nearest 1/4 inch increment.
 2. Temperature rating 360°F (182°C) applies to non-recessed sprinkler assemblies.
 3. TY3339 HSW Quick Response Extended Coverage sprinkler is available in 135°F (57°C) and 155°F (68°C) temperature ratings only.
- * Use Prefix "I" for ISO 7-R 1 Connection (e.g., I-60-110-6-055).