



RAPID RESPONSE Series LFII Residential Sprinklers 5.6 K-factor Horizontal Sidewall, NFPA 13 Optimized Wet Pipe Systems

General Description

The TYCO RAPID RESPONSE Series LFII (TY3334) Residential Horizontal Sidewall Sprinklers are decorative, fast response, frangible bulb sprinklers designed for use in residential occupancies such as homes, apartments, dormitories, and hotels. When enhanced flow characteristics for residential portions of any occupancy per NFPA 13 is the major consideration, the Series LFII (TY3334) should be the first choice.

When higher flow demands are required for residential sprinklers used in an NFPA 13 design, the large 5.6 K-factor of the Series LFII (TY3334) is an attractive choice. Although mostly intended where residential sprinklers are to be used in an NFPA 13 design, the Series LFII (TY3334) can also be used in wet pipe residential sprinkler systems for one- and two-family dwellings and mobile homes per NFPA 13D, and wet pipe residential sprinkler systems for residential occupancies up to and including four stories in height per NFPA 13R.

The recessed version of the Series LFII (TY3334) is intended for use in areas with finished walls. It employs a two-piece Style 20 Recessed Escutcheon. The Recessed Escutcheon provides 1/4 in. (6,4 mm) of recessed adjustment or up to 1/2 in. (12,7 mm) of total adjustment from the flush mounting surface

IMPORTANT

Refer to Technical Data Sheet TFP2300 for warnings pertaining to regulatory and health information.

Always refer to Technical Data Sheet TFP700 for the "INSTALLER WARNING" that provides cautions with respect to handling and installation of sprinkler systems and components. Improper handling and installation can permanently damage a sprinkler system or its components and cause the sprinkler to fail to operate in a fire situation or cause it to operate prematurely.

position. The adjustment provided by the Recessed Escutcheon reduces the accuracy to which the pipe nipples to the sprinklers must be cut.

The Series LFII (TY3334) has been designed with heat sensitivity and water distribution characteristics proven to help in the control of residential fires and to improve the chance for occupants to escape or be evacuated.

Corrosion-resistant coatings, where applicable, are utilized to extend the life of copper alloy sprinklers beyond that which would otherwise be obtained when exposed to corrosive atmospheres. Although corrosion-resistant coated sprinklers have passed the standard corrosion tests of the applicable Approval agencies, the testing is not representative of all possible corrosive atmospheres. Consequently, it is recommended that the end user be consulted with respect to the suitability of these coatings for any given corrosive environment. The effects of ambient temperature, concentration of chemicals, and gas/chemical velocity should be considered, as a minimum, along with the corrosive nature of the chemical to which the sprinklers will be exposed.

NOTICE

The Series LFII (TY3334) Residential Horizontal Sidewall Sprinklers described herein must be installed and maintained in compliance with this document and with the applicable standards of the NATIONAL FIRE PROTECTION ASSOCIATION (NFPA), in addition to the standards of any authorities having jurisdiction. Failure to do so may impair the performance of these devices.

The owner is responsible for maintaining their fire protection system and devices in proper operating condition. Contact the installing contractor or product manufacturer with any questions.



Sprinkler Identification Number (SIN)

TY3334

Technical Data

Approvals

UL and C-UL Listed

Certified to all requirements of NSF/ANSI 61

Note: Sprinklers with a polyester finish are UL Listed as corrosion-resistant sprinklers.

See the Design Criteria section for details on these approvals.

Maximum Working Pressure

Maximum 175 psi (12,1 bar)

Temperature Rating

155°F (68°C) or 175°F (79°C)

Discharge Coefficient

K= 5.6 GPM/psi^{1/2} (80,6 LPM/bar^{1/2})

Finishes

Natural Brass, Pure White Polyester Coated, Signal White Polyester Coated, or Chrome Plated

Components:

- 1 - Frame
- 2 - Button Assembly
- 3 - Sealing Assembly
- 4 - Bulb
- 5 - Compression Screw
- 6 - Deflector*

* Temperature rating is indicated on top of Deflector.

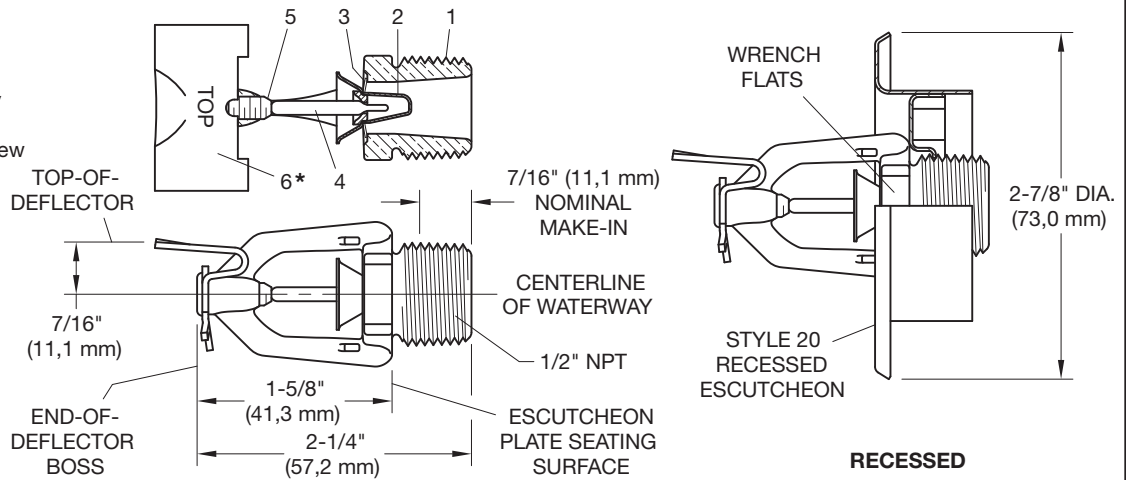

FIGURE 1
RAPID RESPONSE SERIES LFII RESIDENTIAL HORIZONTAL SIDEWALL AND RECESSED HORIZONTAL SIDEWALL SPRINKLER (TY3334)

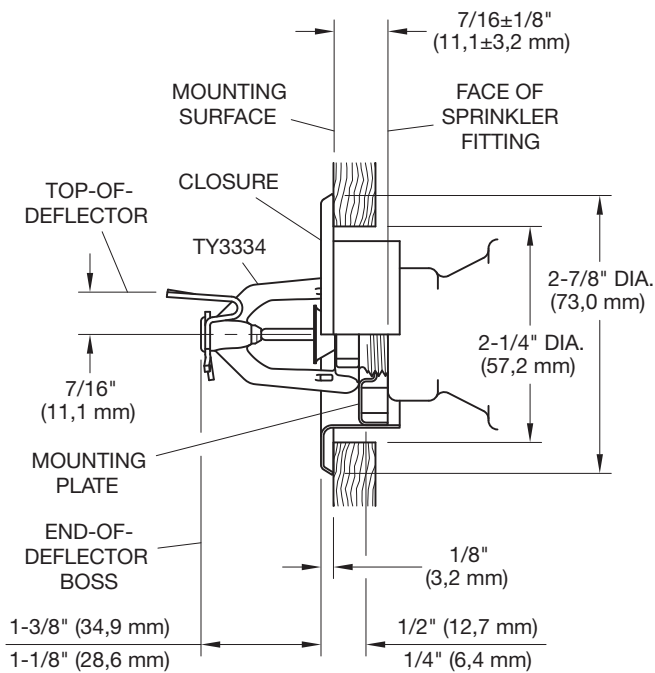

FIGURE 2
STYLE 20 RECESSED ESCUTCHEON FOR USE WITH THE RAPID RESPONSE SERIES LFII RESIDENTIAL HORIZONTAL SIDEWALL SPRINKLER (TY3334)

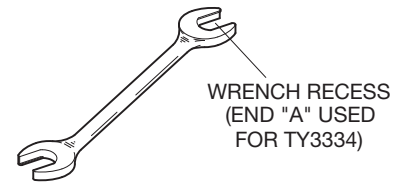

FIGURE 3
W-TYPE 6 SPRINKLER WRENCH

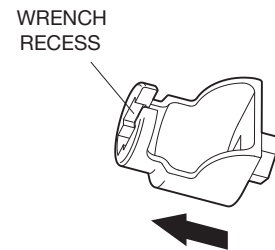

FIGURE 4
W-TYPE 7 RECESSED SPRINKLER WRENCH

Physical Characteristics

Frame	Brass
Button	Copper
Sealing Assembly	Beryllium Nickel w/ TEFLON
Bulb	3 mm dia. Glass
Compression Screw	Brass
Deflector	Bronze

Operation

The glass bulb contains a fluid that expands when exposed to heat. When the rated temperature is reached, the fluid expands sufficiently to shatter the glass bulb allowing the sprinkler to activate and flow water.

Design Criteria

The TYCO RAPID RESPONSE Series LFII (TY3334) Residential Horizontal Sidewall Sprinklers are UL and C-UL Listed for installation in accordance with this section.

Residential Sprinkler Design Guide
When conditions exist that are outside the scope of the provided criteria, refer to the Residential Sprinkler Design Guide TFP490 for the manufacturer’s recommendations that may be acceptable to the local authority having jurisdiction.

System Type
Only wet pipe systems may be utilized.

Ceiling Type
Smooth flat horizontal, or beamed, or sloped, in accordance with the 2013 Edition of NFPA 13D, 13R, or 13 as applicable.

Hydraulic Design (NFPA 13D and 13R)
For systems designed to NFPA 13D or NFPA 13R, the minimum required sprinkler flow rate are given in Table A as a function of temperature rating and the maximum allowable coverage areas. The sprinkler flow rate is the minimum required discharge from each of the total number of design sprinklers as specified in NFPA 13D or NFPA 13R.

Hydraulic Design (NFPA 13)
For systems designed to NFPA 13, the number of design sprinklers is to be the four most hydraulically demanding sprinklers. The minimum required discharge from each of the four sprinklers is to be the greater of the following:

- The flow rates given in Table A as a function of temperature rating and the maximum allowable coverage area.

- A minimum discharge of 0.1 gpm/ft² over the “design area” comprised of the four most hydraulically demanding sprinklers for the actual coverage areas being protected by the four sprinklers.

Obstruction To Water Distribution
Sprinklers are to be located in accordance with the obstruction rules of NFPA 13D, 13R, and 13 as applicable for residential sprinklers as well as with the obstruction criteria described within the TYCO Technical Data Sheet TFP490.

Operational Sensitivity
The sprinklers are to be installed with an end-of deflector-boss to wall distance of 1-1/4 in. to 6 in.

In addition the top-of-deflector-to-ceiling distance is to be within the range (Table A) being hydraulically calculated.

Sprinkler Spacing
The minimum spacing between sprinklers is 8 ft (2,4 m) when installed with a top-of-deflector-to-ceiling distance of 4 in. to 6 in. (100 to 150 mm). The minimum spacing between sprinklers is 9 ft (2,7 m) when installed with a top-of-deflector-to-ceiling distance of 6 in. to 12 in. (150 to 300 mm). The maximum spacing between sprinklers cannot exceed the width of the coverage area (see Table A) being hydraulically calculated (for example, maximum 12 ft for a 12 ft x 12 ft coverage area, or 16 ft for a 16 ft x 20 ft coverage area).

Installation

The TYCO RAPID RESPONSE Series LFII (TY3334) Residential Horizontal Sidewall Sprinkler must be installed in accordance with this section.

General Instructions
Do not install any bulb-type sprinkler if the bulb is cracked or there is a loss of liquid from the bulb. With the sprinkler held horizontally, a small air bubble should be present. The diameter of the air bubble is approximately 1/16 in. (1,6 mm).

A leak-tight 1/2 in. NPT sprinkler joint should be obtained by applying a minimum to maximum torque of 7 to 14 lb-ft (9,5 to 19,0 N·m). Higher levels of torque can distort the sprinkler Inlet with consequent leakage or impairment of the sprinkler.

Do not attempt to compensate for insufficient adjustment in the Sprinkler by under- or over-tightening the sprinkler. Re-adjust the position of the sprinkler fitting to suit.

Series LFII Horizontal Sidewall Sprinklers

The Series LFII Horizontal Sidewall Sprinklers must be installed in accordance with the following instructions.

Step 1. Horizontal sidewall sprinklers are to be installed in the horizontal position with their centerline of waterway perpendicular to the back wall and parallel to the ceiling. The word “TOP” on the Deflector is to face towards the ceiling with the front edge of the Deflector parallel to the ceiling.

Step 2. With pipe thread sealant applied to the pipe threads, hand tighten the sprinkler into the sprinkler fitting.

Step 3. Tighten the sprinkler into the sprinkler fitting using only the W-Type 6 Sprinkler Wrench (Figure 3). With reference to Figure 1, the W-Type 6 Sprinkler Wrench is to be applied to the wrench flats.

Series LFII Recessed Horizontal Sidewall Sprinklers

The Series LFII Recessed Horizontal Sidewall Sprinklers must be installed in accordance with the following instructions.

Step A. Recessed horizontal sidewall sprinklers are to be installed in the horizontal position with their centerline of waterway perpendicular to the back wall and parallel to the ceiling. The word “TOP” on the Deflector is to face towards the ceiling.

Step B. After installing the Style 20 Mounting Plate over the sprinkler threads and with pipe thread sealant applied to the pipe threads, hand tighten the sprinkler into the sprinkler fitting.

Step C. Tighten the sprinkler into the sprinkler fitting using only the W-Type 7 Recessed Sprinkler Wrench (see Figure 4). With reference to Figure 1, the W-Type 7 Recessed Sprinkler Wrench is to be applied to the sprinkler wrench flats.

Step D. After the wall has been installed or the finish coat has been applied, slide on the Style 20 Closure over the Series LFII Sprinkler and push the Closure over the Mounting Plate until its flange comes in contact with the wall.

Max. Coverage Area ^(a) Width x Length ^(d) ft x ft (m x m)	Max. Spacing ft (m)	Minimum Flow and Residual Pressure ^(b, c)								
		Ordinary Temp. Rating 155°F (68°C)		Intermediate Temp. Rating 175°F (79°C)		Deflector to Ceiling	Installation Type	Minimum Spacing ft (m)		
		Flow GPM (L/min)	Pressure PSI (bar)	Flow GPM (L/min)	Pressure PSI (bar)					
12 x 12 (3,7 x 3,7)	12 (3,7)	17 (64,3)	9.2 (0,63)	17 (64,3)	9.2 (0,63)	4 in. to 6 in.	1/2 in. recessed using Style 20 Escutcheon or non-recessed per NFPA 13D, 13R, or 13	8 (2,4)		
14 x 14 (4,3 x 4,3)	14 (4,3)	19 (71,9)	11.5 (0,79)	19 (71,9)	11.5 (0,79)					
16 x 14 (4,9 x 4,3)	16 (4,9)	20 (75,7)	12.8 (0,88)	20 (75,7)	12.8 (0,88)					
16 x 16 (4,9 x 4,9)	16 (4,9)	24 (90,8)	18.4 (1,27)	24 (90,8)	18.4 (1,27)					
16 x 18 (4,9 x 5,5)	16 (4,9)	26 (98,4)	21.6 (1,49)	26 (98,4)	21.6 (1,49)					
16 x 20 (4,9 x 6,1)	16 (4,9)	29 (109,8)	26.8 (1,85)	29 (109,8)	26.8 (1,85)					
12 x 12 (3,7 x 3,7)	12 (3,7)	20 (75,7)	12.8 (0,88)	20 (75,7)	12.8 (0,88)	6 in. to 12 in.			1/2 in. recessed using Style 20 Escutcheon or non-recessed per NFPA 13D, 13R, or 13	8 (2,4)
14 x 14 (4,3 x 4,3)	14 (4,3)	22 (83,3)	15.4 (1,06)	22 (83,3)	15.4 (1,06)					
16 x 14 (4,9 x 4,3)	16 (4,9)	24 (90,8)	18.4 (1,27)	24 (90,8)	18.4 (1,27)					
16 x 16 (4,9 x 4,9)	16 (4,9)	28 (106,0)	25.0 (1,72)	28 (106,0)	25.0 (1,72)					
16 x 18 (4,9 x 5,5)	16 (4,9)	31 (117,3)	30.6 (2,11)	31 (117,3)	30.6 (2,11)					
16 x 20 (4,9 x 6,1)	16 (4,9)	37 (140,0)	43.7 (3,01)	37 (140,0)	43.7 (3,01)					

Notes:

- a. For coverage area dimensions less than or between those indicated, use the minimum required flow for the next highest coverage area for which hydraulic design criteria are stated.
- b. Requirement is based on minimum flow in GPM (LPM) from each sprinkler. The associated residual pressures are calculated using the nominal K-factor. See Hydraulic Design under the Design Criteria section.
- c. For NFPA 13 residential applications, the greater of 0.1 gpm/ft² over the design area or the flow in accordance with the criteria in this table must be used.
- d. The Width x Length dimension refers to the Width (backwall where the sprinkler is located) times the Length (horizontal throw of sprinkler).

TABLE A
WET PIPE SYSTEMS
SERIES LFII (TY3334) RESIDENTIAL HORIZONTAL SIDEWALL
AND RECESSED HORIZONTAL SIDEWALL SPRINKLERS (TY3334)
NFPA 13D, 13R AND 13 WET PIPE HYDRAULIC DESIGN CRITERIA

Care and Maintenance

The TYCO RAPID RESPONSE LFII (TY3334) Residential Horizontal Sidewall Sprinklers must be maintained and serviced in accordance with this section.

Before closing a fire protection system main control valve for maintenance work on the fire protection system which it controls, permission to shut down the affected fire protection system must be obtained from the proper authorities and all personnel who may be affected by this action must be notified.

Absence of an Escutcheon Plate may delay the sprinkler operation in a fire situation.

The owner must assure that the sprinklers are not used for hanging of any objects and that the sprinklers are only cleaned by means of gently dusting with a feather duster; otherwise, non-operation in the event of a fire or inadvertent operation may result.

Sprinklers which are found to be leaking or exhibiting visible signs of corrosion must be replaced.

Automatic sprinklers must never be painted, plated, coated, or otherwise altered after leaving the factory. Modified sprinklers must be replaced. Sprinklers that have been exposed to corrosive products of combustion, but have not operated, should be replaced if they cannot be completely cleaned by wiping the sprinkler with a cloth or by brushing it with a soft bristle brush.

Care must be exercised to avoid damage to the sprinklers - before, during, and after installation. Sprinklers damaged by dropping, striking, wrench twist/slippage, or the like, must be replaced. Also, replace any sprinkler that has a cracked bulb or that has lost liquid from its bulb. See the Installation section for additional information.

The owner is responsible for the inspection, testing, and maintenance of their fire protection system and devices in compliance with this document, as well as with the applicable standards of the NATIONAL FIRE PROTECTION ASSOCIATION, for example, NFPA 25, in addition to the standards of any other authorities having jurisdiction. Contact the installing contractor or product manufacturer with any questions.

Automatic sprinkler systems are recommended to be inspected, tested, and maintained by a qualified Inspection Service in accordance with local requirements and/or national code.

Ordering Procedure

Contact your local distributor for availability. When placing an order, indicate the full product name and Part Number (P/N).

Sprinkler Assembly

Series LFII (TY3334), K=5.6, Residential Horizontal Sidewall Sprinkler, (specify) temperature rating, (specify) finish, P/N (specify):

155°F (68°C)

Natural Brass	51-524-1-155
Pure White (RAL9010)	
Polyester ^{1, 2}	51-524-3-155
Signal White (RAL9003)	
Polyester ¹	51-524-4-155
Chrome Plated	51-524-9-155

175°F (79°C)

Natural Brass	51-524-1-175
Pure White (RAL9010)	
Polyester ^{1, 2}	51-524-3-175
Signal White (RAL9003)	
Polyester ¹	51-524-4-175
Chrome Plated	51-524-9-175

1. UL Listed as corrosion-resistant.
2. Eastern Hemisphere sales only.

Recessed Escutcheon

Specify: Style 20 Recessed Escutcheon with (specify*) finish, P/N (specify*).

* Refer to Technical Data Sheet TFP770.

Sprinkler Wrench

Specify: W-Type 6 Sprinkler Wrench, P/N 56-000-6-387

Specify: W-Type 7 Sprinkler Wrench, P/N 56-850-4-001

