



RAPID RESPONSE

Model RCP-1 Residential Control Panel

1 or 1-1/2 Inch (DN25 or DN40), 175 psi (12,1 bar)

General Description

The TYCO RAPID RESPONSE Model RCP-1 Residential Control Panel is an integrated valve manifold, air pressure, and electronic control package for controlling the release of water into residential dry pipe sprinkler systems.

The Model RCP-1 Panel is intended for use in one- and two- family dwellings and mobile homes per NFPA 13D when used with residential sprinklers that have been listed for use in residential dry pipe sprinkler systems.

The Model RCP-1 Panel incorporates the Listed Model 4004R Household Fire Warning Unit Subassembly installed within the Model RCP-1 cabinet.

The Model RCP-1 Panel includes the following features:

- Pre-wired assembly containing pre-programmed control panel, system performance gauges, and an enclosed compressor
- Pre-engineered riser design
- Supervised system valve system
- Provision to trip test system without having water flow into the system.
- High pressure supervision for indication of a false trip or failure of the automatic air supply cut-out switch
- Dry contacts for remote connection (dial-up systems or additional monitoring, for example)
- 48-hour battery backup

Warnings

General

The RAPID RESPONSE Residential Dry Pipe System described herein must be installed and maintained by qualified personnel in compliance with this document, and with the applicable standards of the NATIONAL FIRE PROTECTION ASSOCIATION, in addition to the requirements of any other authorities having jurisdiction. Failure to do so may impair the performance of this device.

Owner Responsibility

Owners are responsible for maintaining their fire protection system and devices in proper operating condition and in compliance with all applicable standards and requirements. Contact the installing contractor or product manufacturer with any questions.

Do NOT Disconnect Batteries or Turn Off AC Power to Quiet Unwanted Alarms.

The Model RCP-1 Panel will not operate (that is, release water or energize alarms) if AC power is not connected, has failed, or has been interrupted for any reason AND the battery is disconnected, drained, or improperly connected.

Household Fire Alarm System

The use of an automatic sprinkler system does not allow for omission of a "Household Fire Alarm System" installed per NFPA 72. The Model RCP-1 Panel is not intended to be used as part of a "Household Fire Alarm System".

Electrical Hazard

Disconnect electrical field power when making any internal adjustments or repairs. Failure to do so may result in personal injury. Servicing should be performed by qualified personnel.

Static Hazard

Static electricity can damage components. Therefore, qualified personnel must be grounded before opening



components, installing components, and prior to installation. Keep components wrapped in anti-static material at all times.

Radio Frequency Energy

This equipment generates, uses, and can radiate radio frequency energy, and if not installed and used in accordance with this technical data sheet, may cause interference to radio communications. This equipment has been tested and found to comply with the limits for a Class A computing device pursuant to Subpart J of Part 15 of FCC Rules, that are designed to provide reasonable protection against such interference when operated in a commercial environment. However, operation of this equipment in a residential area may cause interference, in which case the user, at their own expense, will be required to take whatever measure may be required to correct the interference.

System Re-Acceptance Test

To ensure proper operation, this product must be retested by qualified personnel in accordance with the Care and Maintenance section after any modification, repair, or adjustment. Retesting is required to assure that the system is operating as intended.

IMPORTANT

Refer to Technical Data Sheet TFP2300 for warnings pertaining to regulatory and health information.

Technical Data

Approvals

The Model RCP-1 Residential Control Panel is UL Listed for use in residential dry pipe sprinkler systems installed in one and two-family dwellings and mobile homes per NFPA 13D when installed in accordance with this document.

The Model 4004R Household Fire Warning Unit Subassembly (Electronic Control) installed within the Model RCP-1 cabinet is UL and C-UL Listed.

Maximum Water Pressure

175 psi (12,1 bar)

Friction Loss

Refer to Graph A

Input Voltage

120 VAC, 60 Hz, 4 A

Battery Backup

Two 8.0 amp-hour 12 VDC batteries in series provides a minimum of 48 hours of standby and a minimum of 15 minutes of alarm/system release. The 15 minutes of alarm/system release provides a 150% safety factor as compared to the 10-minute requirement of NFPA 13D.

The battery size is pre-calculated based on a maximum 1A rating for NAC1 (Notification Appliance Circuit -Horns), and a maximum 0.25A rating for auxiliary devices. The battery backup does not provide power to the air compressor in the event of primary 120 VAC power failure.

Battery Charger

Backup batteries provide a 48-hour standby and 15-minute alarm/system release. Batteries automatically recharge within 24 hours.

Depleted Battery Operation

The system monitors the battery voltage and indicates a trouble status when the battery is outside its normal range. There are two battery trouble levels: Low Battery and Depleted Battery. When Low Battery is detected, the system sounds the tone-alert (piezo) and flashes the trouble LED. The event must be accepted by pressing the ACCEPT SIGNAL KEY. If discharge continues further, and the batteries reach the depleted state, once again the tone-alert activates and the trouble LED flashes.

Initiating Device Circuit (IDCs)

IDC1 is internally wired to the system's low pressure switch, and no other devices are to be connected to IDC1. IDC2, IDC3, and IDC4 are spares and are not to be utilized.

Notification Appliance Circuit (NACs)

NAC1 is rated at 1 A. NAC2 is a spare and is not to be utilized.

Notification Appliances

NFPA 13D does not require the installation of a waterflow alarm (notification appliance device).

If needed, notification appliances can be installed to indicate release of the Model RCP-1 Panel.

When installed, notification appliances must be installed in accordance with the applicable requirements of NFPA 72. Per the requirements of NFPA 72, fire warning equipment for dwelling units shall provide a sound that is audible in all occupiable dwelling areas.

Auxiliary Device Power Supply

The Auxiliary Device Power Supply is rated at 0.25A. If desired and where the system is not otherwise monitored by a central control station, the Auxiliary Device Power Supply can be used to power a remote visual signal of an alarm, supervisory, or trouble condition through use of the relay contacts (Ref. Figure 5). This arrangement is especially convenient when the Model RCP-1 Panel is located in an area where its Tone Alert is not readily heard or the Operator Interface is not readily apparent. The circuitry, while operable by battery backup, is not a supervised circuit.

LED/Keypad Operator Interface

- Red Alarm LED for IDC1 and to indicate system release.
- Yellow Trouble LEDs for each IDC, NAC, RAC, and SPM.
- Dedicated Alarm Silence, Supervisory, and Earth Fault Trouble LEDs.
- Green LED for AC Power ON.
- KEYS for Accept, Silence, and Reset.

Tone Alert (Piezo)

- On trouble conditions, the tone-alert sounder is on steady to indicate that a trouble has occurred. It turns off when ACCEPT SIGNAL KEY is pressed.
- On alarm conditions, the tone-alert pulses until the ACCEPT SIGNAL KEY is pressed.

Environmental

This equipment operates normally within the temperature range of 32 °F to 120 °F (0 °C to 49 °C), inclusive. This equipment operates normally under non-condensing humidity conditions up to 93% humidity at 90 °F (32 °C).

Automatically Controlled System Air Pressure

10 to 14 psi

System Alarm (Trip/Release) Pressure

8 ± 1 psi

Supervisory High Pressure

16 ± 1 psi

Assembly

The Manifold Assembly (Ref. Figure 2) is of brass and bronze construction.

Trip Ratio

When applying a water delivery calculation program for determining that the water delivery will not exceed 15 seconds, the trip ratio of the Model RCP-1 Panel must be entered into the program. The trip ratio for the Model RCP-1 Panel is determined by dividing the available static water supply pressure by 7 psi. The use of 7 psi is based on the tolerance of the system alarm trip/release pressure, where 7 psi is the lowest potential trip pressure. For example if the available static water supply pressure is 30 psi, the trip ratio is 30 divided by 7 (that is, 4.3:1). For an available 130 psi static water supply, the trip ratio is 130 divided by 7 (that is, 18.6:1).

Operation

The system is automatically maintained at a normal system air pressure of 10 to 14 psi (0,7 to 1,0 bar) via the Air Compressor Switch/Air Compressor (Ref. Figure 2). In the standby condition, water is prevented from entering the system piping until the Solenoid Valve in the Manifold Assembly is opened in response to the electronic control.

The operation sequence is listed below.

- The normal standby condition is AC green light ON.
- Closure of Main Control Valve, closure of System Control Valve, or a high system pressure condition results in a supervisory condition (SPM1).
During a Supervisory Condition, the Yellow SUPERVISORY LED flashes and the tone-alert sounds steady. After accepting, the tone-alert silences and the Yellow SUPERVISORY LED stays ON until the condition clears.
- Opening of a sprinkler results in a low air condition of less than nominally 8 psi (0,6 bar) resulting in an alarm condition ON IDC1, opening of the Solenoid Valve (RAC1), and operation of alarm notification devices (NAC1).

During an Alarm Condition, the Red ALARM LED, corresponding to Zone or SPM in alarm, flashes and the tone-alert pulses. After accepting, the tone-alert silences and the Red ALARM LED stays ON until the alarm condition clears.

Operator Interface

The Model RCP-1 Panel uses LEDs and KEYS as its primary means of displaying status information and controlling the system. It allows the occupants to monitor the status of the Model RCP-1 Panel and its circuits.

The LEDs are located along the left and right sides of the Operator Interface (Ref. Figure 3). Three KEYS are located along the lower edge of the Operator Interface.

LEDs

- **ALARM LEDs**
A flashing red LED adjacent to the SPRINKLER (IDC1) indicates an alarm.
- **TROUBLE LEDs**
A flashing yellow Trouble LED for one of the IDCs, NACs, or RACs indicates the presence of a circuit break or ground within a system point, or somewhere in the wiring between the control panel and one of its points.
- **SUPERVISORY LED**
A flashing yellow SUPERVISORY LED indicates a problem with the condition of the sprinkler system controls or normal status (for example, closed valve position for Main Control Valve, closed valve position for System Control Valve, or high air condition).
- **SYSTEM TROUBLE LED**
When a TROUBLE condition occurs, the SYSTEM TROUBLE LED flashes until accepted. When accepted, it changes from flashing to steady.
- **AC POWER LED**
When lit steady, the Green AC POWER LED indicates that the Electronic Control of the Model RCP-1 Panel is receiving AC power that is within the specified range.

If the LED is not lit and the Panel is still functioning, the Electronic Control is using battery power to operate. The cause for loss of AC Power should be determined and corrected. The system is in a normal standby condition when only the Green AC POWER LED is ON.
- **SYSTEM RELEASED LED**
The Red SYSTEM RELEASED LED turns on steady when the RAC circuit is activated. Activation of the RAC circuit energizes the Solenoid Valve to permit water to enter the sprinkler system piping. RAC1 is utilized, and RAC2 is spare.

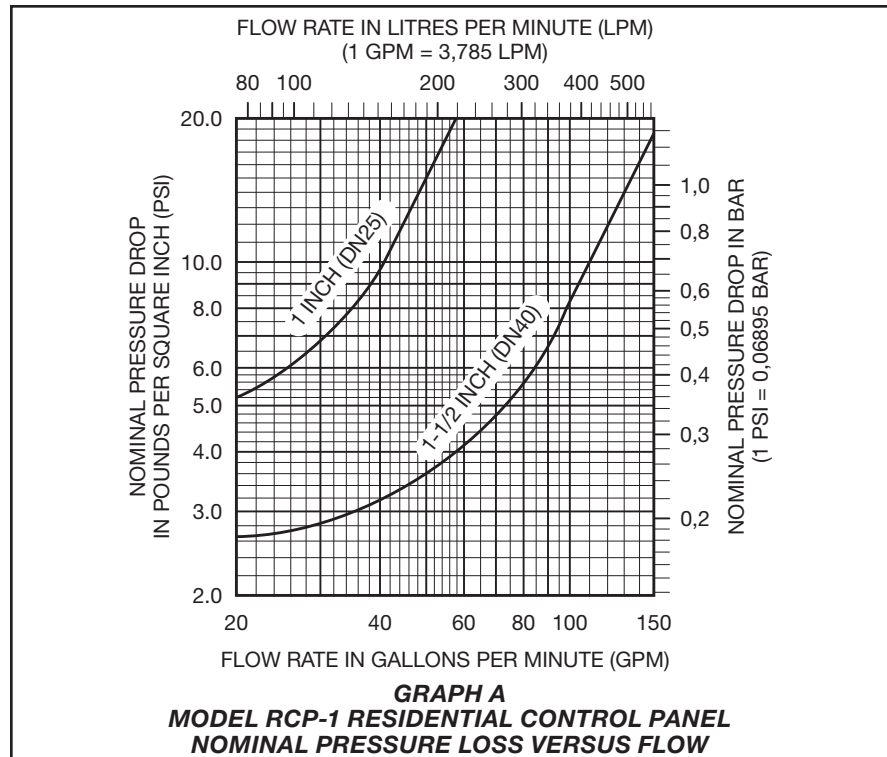

- **EARTH FAULT LED**
The Yellow EARTH FAULT LED turns on steady when there is a wiring fault from circuit to Earth.
 - **Lamp (LED) Test**
A lamp (LED) test can be performed by pressing and holding the ACCEPT SIGNAL KEY for a duration of five seconds. Performing a lamp test lights all LEDs on the system and verifies that all system LEDs are functioning.
- KEYS**
- **ACCEPT SIGNAL KEY**
The system LEDs (ALARM, SUPERVISORY, TROUBLE) flash to indicate the presence of an unaccepted alarm, supervisory, or trouble condition somewhere in the system. The ACCEPT SIGNAL KEY acknowledges the presence of an alarm, supervisory, or trouble condition.

By momentarily pressing the ACCEPT SIGNAL KEY, the flashing LED turns steady. The ACCEPT SIGNAL KEY is used to acknowledge every abnormal status present in the system. For example, if there are two red alarms and three yellow

troubles, the ACCEPT SIGNAL KEY must be pressed five times.

The Panel's tone-alert turns off when all abnormal conditions are accepted.

- **SIGNAL SILENCE KEY**
Pressing the SIGNAL SILENCE KEY silences the audible notification devices (horns). The Yellow ALARM SILENCED LED lights to indicate that an alarm is still active even if the audible alarms have been silenced.
- **SYSTEM RESET KEY**
Pressing the SYSTEM RESET KEY directs the Panel to reset all attached devices and clear all accepted alarms, troubles, and supervisory conditions. All alarms must first be accepted via the ACCEPT SIGNAL KEY and all devices must be reset (that is, normal system air pressure is re-established).

Note: After pressing the SYSTEM RESET KEY, the panel requires approximately fifteen seconds to clear.

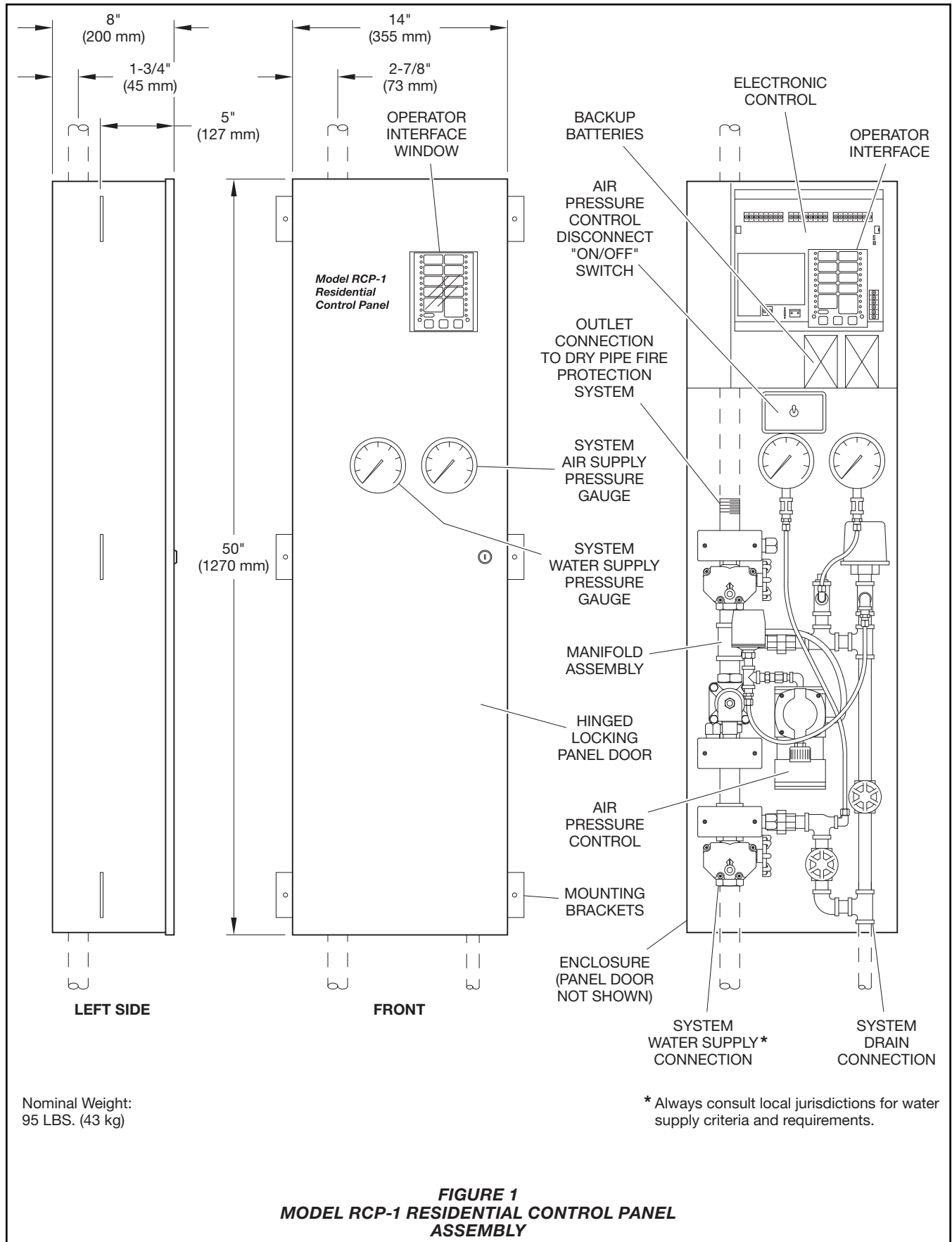

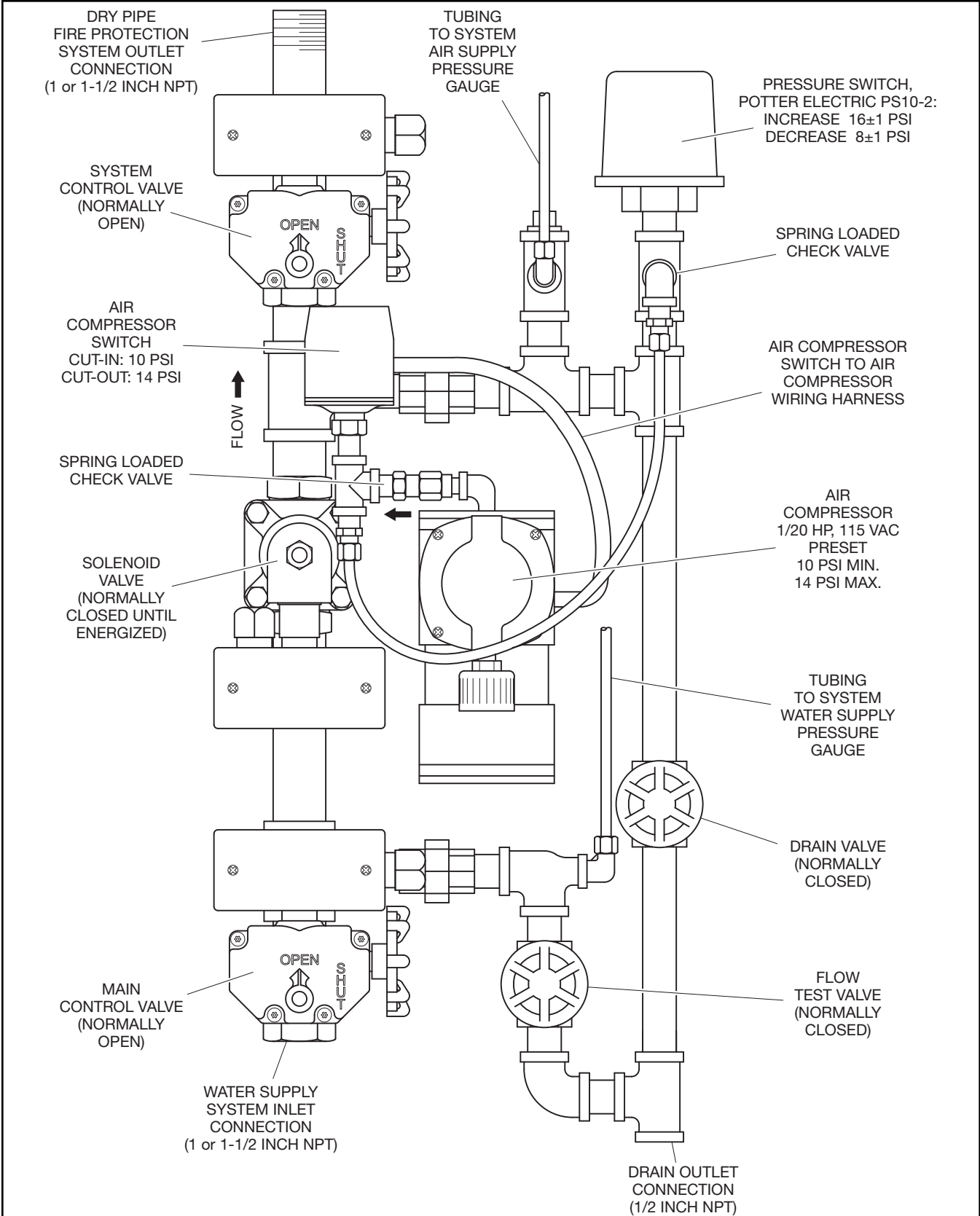
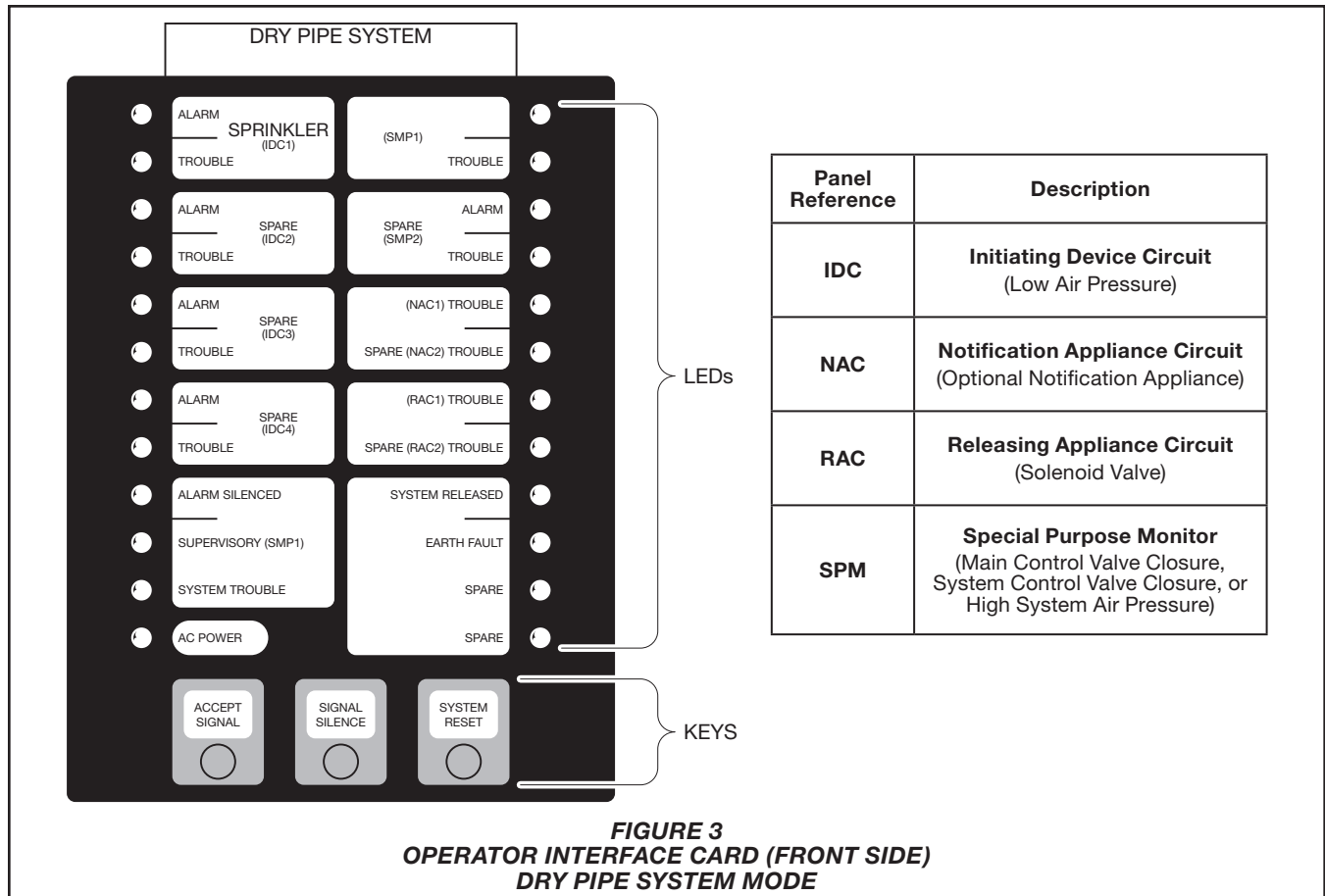

FIGURE 2
MODEL RCP-1 RESIDENTIAL CONTROL PANEL
MANIFOLD ASSEMBLY



In Case of Supervisory/Trouble Condition

Step 1. Verify that a fire condition does not exist.

Step 2. Close the Main Control Valve to prevent inadvertent water flow into the system.

Step 3. Acknowledge the supervisory/trouble notification by momentarily pressing the ACCEPT SIGNAL KEY. Doing so silences the tone-alert.

Step 4. Determine and correct cause of supervisory/trouble notification, for example:

- Loss of primary 120 VAC power
- Low battery condition
- High air pressure
- System or main control valve closure

Step 5. Reset the system as soon as possible.

In Case of Alarm Condition

Step 1. Verify that a fire condition exists and take appropriate action (that is, evacuate the building and call fire department).

Step 2. After the fire is extinguished, reset the system.

If a fire condition does not exist and prior to resetting the system, silence the alarms as follows:

- First, momentarily press the ACCEPT SIGNAL KEY a sufficient number of times to stop the tone-alert.
- Second, momentarily press the SIGNAL SILENCE KEY.

System Resetting

Step 1. Use the ACCEPT SIGNAL KEY to accept every abnormal status present in the system.

For example, when two red ALARM and three yellow TROUBLE conditions are present, the ACCEPT SIGNAL KEY must be pressed five times. The Panel's tone-alert turns off when all abnormal conditions are accepted.

Step 2. Silence the alarms by pressing the SIGNAL SILENCE KEY.

Step 3. Close the Main Control Valve.

Step 4. Place the Air Compressor Disconnect Switch to the OFF position.

Step 5. Open the Drain and Flow Test Valves.

Step 6. Replace operated sprinklers.

Step 7. After the system drains completely, close the Drain and Flow Test Valves.

Step 8. Place the Air Compressor Disconnect Switch to the ON position and allow the system to automatically reestablish its normal air pressure of 10 to 14 psi.

Step 9. Reset the Electronic Control by pressing the SYSTEM RESET KEY.

Wait approximately fifteen seconds for the Electronic Control to clear.

A supervisory signal will remain because the Main Control Valve is still closed.

Press the ACCEPT SIGNAL KEY to accept the supervisory signal and silence the tone-alert.

Step 10. Slowly open the Main Control Valve. (Opening the Control Valve too quickly may result in activation of the pressure switch.)

The supervisory signal should clear and the system is now set for service.

NOTICE

After pressing the SYSTEM RESET KEY, the panel requires approximately fifteen seconds to clear.

Installation

The RAPID RESPONSE Model RCP-1 Residential Control Panel described herein must be installed and maintained in compliance with this document, as well as with the applicable standards of the NATIONAL FIRE PROTECTION ASSOCIATION, in addition to the requirements of any other authorities having jurisdiction. Failure to do so may impair the performance of this device.

The Model RCP-1 Residential Control Panel may be surface-mounted or recessed-mounted with a separately ordered bezel. In either case the Model RCP-1 Panel must be located in an area not subject to freezing.

Field connections are as follows:

- Water Supply Line
- System Riser Line
- Drain Line
- Electrical

NOTICE

Do not attempt to reprogram the Model RCP-1 Panel. If assistance is required, contact Johnson Controls Technical Services.

Electrical Field Wiring

The Electronic Control has been shipped with resistors located across all required contact points.

NOTICE

Remove resistors only when instructed to do so. Failure to do so may lead to improper conditions or failure of the Model RCP-1 Panel to function properly.

The cover is electrically bonded to the enclosure ground terminal by means of an 18 AWG conductor. Do not remove the electrical bond.

Do not place any wiring in contact with CPVC pipe and fittings. Plasticizers, such as those found in flexible wire insulation, can damage the pipe and fittings through contact resulting in damage/failure to the system.

Wiring Notification Appliances (Optional)

Notification appliances (horns) are optional for waterflow alarms (that is, release of water into the system).

Adhere to the following guidelines when wiring NAC1:

- Remove the 10K, 1/2 W resistor from the NAC1 terminals.
- All wiring must be from 12 AWG (maximum) to 18 AWG (minimum).
- Conductors must test free of all grounds.
- Terminal designations “+” or “-” are for alarm state.
- Maximum alarm current is 1A, and the maximum distance from the Model RCP-1 Panel to the last device is as follows:
 - 210 feet for 18 AWG wiring
 - 334 feet for 16 AWG wiring
 - 532 feet for 14 AWG wiring
 - 845 feet for 12 AWG wiring.
- Terminate circuit with a 10K, 1/2 W end-of-line resistor (Ref. Figure 4).

Wiring Relay Connections (Optional)

These connections provide optional monitoring by a central control station or for a remote signal on premise. Adhere to the following guidelines when wiring relay modules:

- All wiring must be from 12 AWG (maximum) to 18 AWG (minimum).
- Conductors must test free of all grounds.
- Relay circuits are rated for 2 A at 30 VDC, pilot duty (0.35 power factor).
- Circuit is not supervised.
- All relays are single pole, double throw. Refer to Figure 5 to set selectable jumpers for normally open or normally closed jumpers.
- Refer to Figure 6 for recommendation on wiring a remote signal on premise. As shown, an alarm, supervisory, or trouble signal will result in activation of the remote signal.

Wiring AC Power and Batteries

Step 1. Close the Main Control Valve and open the Main Drain Valve.

Step 2. Place the Air Compressor Disconnect switch in the OFF position.

Step 3. Connect the batteries using the provided harness per Figure 7. Leave one of the connections unconnected as shown until directed otherwise.

Step 4. At the power supply junction box, connect the Model RCP-1 Panel to a dedicated branch circuit per all local codes.

IDC1 will go into alarm. Silence the alarm by pressing the SIGNAL SILENCE KEY. Accept the alarm condition by momentarily pressing the ACCEPT SIGNAL KEY.

System Trouble will be indicated for lack of the battery connection. Accept the trouble condition by momentarily pressing the ACCEPT SIGNAL KEY.

A Supervisory Condition will be indicated due to the Main Control Valve being closed. Acknowledge the supervisory condition by momentarily pressing the ACCEPT SIGNAL KEY.

Step 5. Connect the remaining battery connection.

The system may now be set for service.

Care and Maintenance

The following inspection/test procedure for the RAPID RESPONSE Model RCP-1 Residential Control Panel must be performed as indicated, in addition to any specific requirements of the NFPA. Any impairment must be immediately corrected.

Before closing a fire protection system control valve for inspection or maintenance work on the fire protection system that it controls, obtain permission to shut down the effected fire protection system from the proper authorities and notify all personnel who may be affected by this action.

The following inspection/test procedures will result in operation of the associated alarms. Notify the proper authorities and advise those responsible for monitoring proprietary and/or central station alarms.

After placing a fire protection system in service, notify proper authorities and advise those responsible for monitoring proprietary and/or central station alarms.

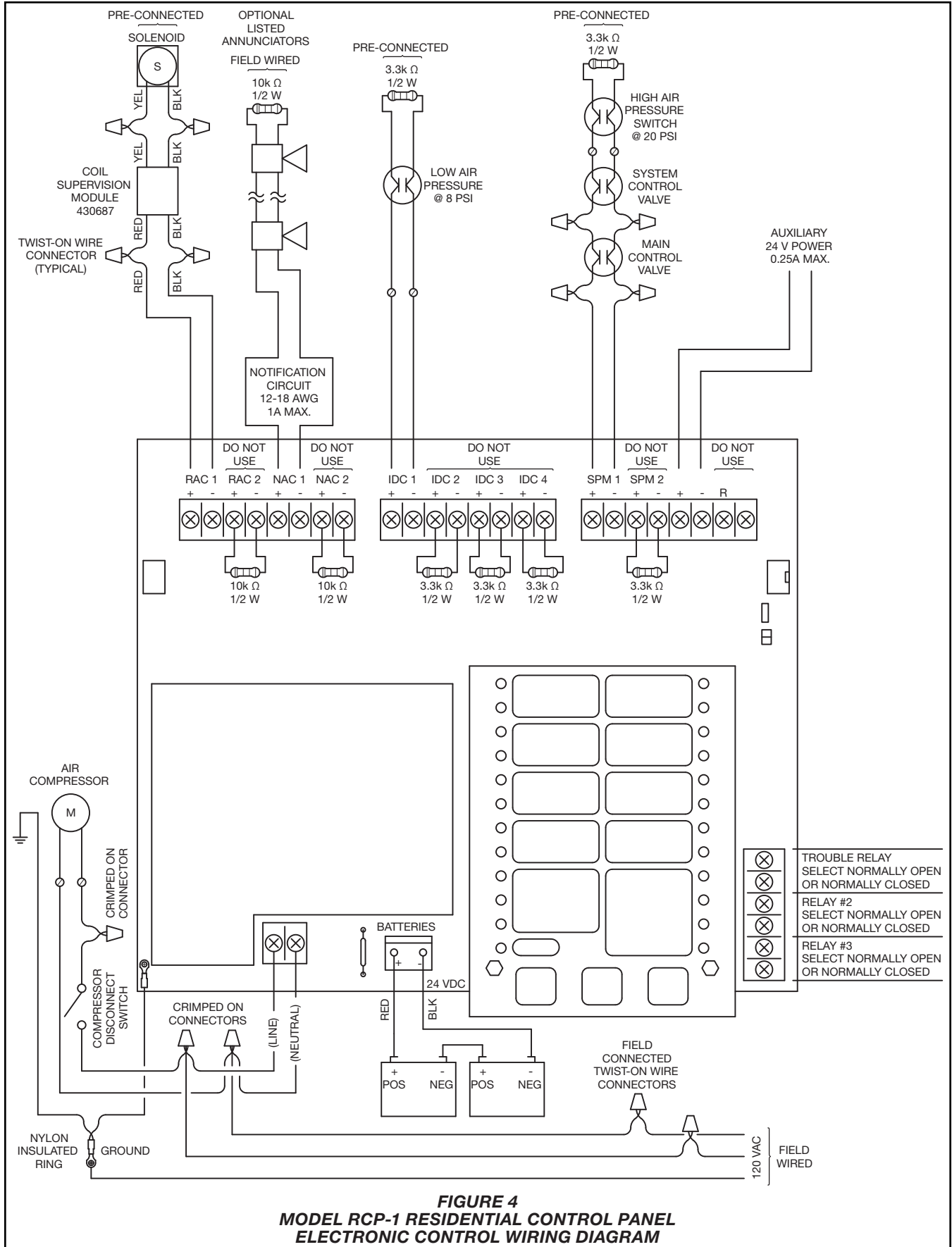
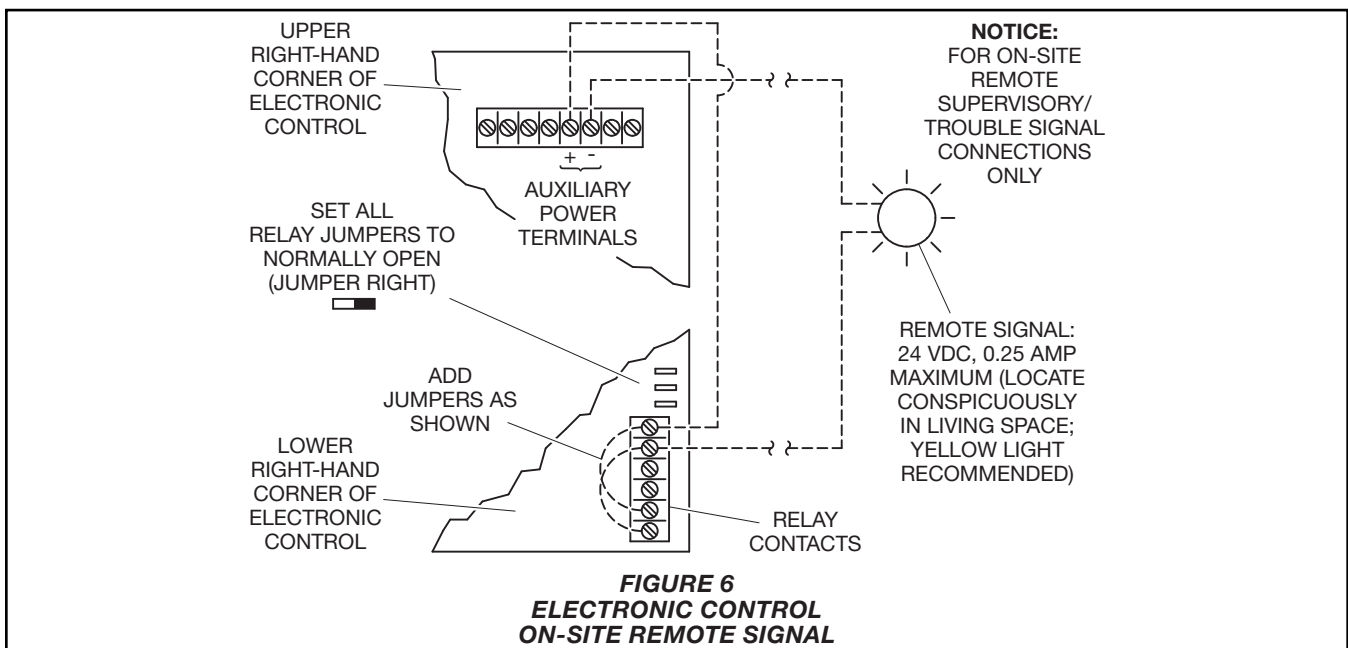
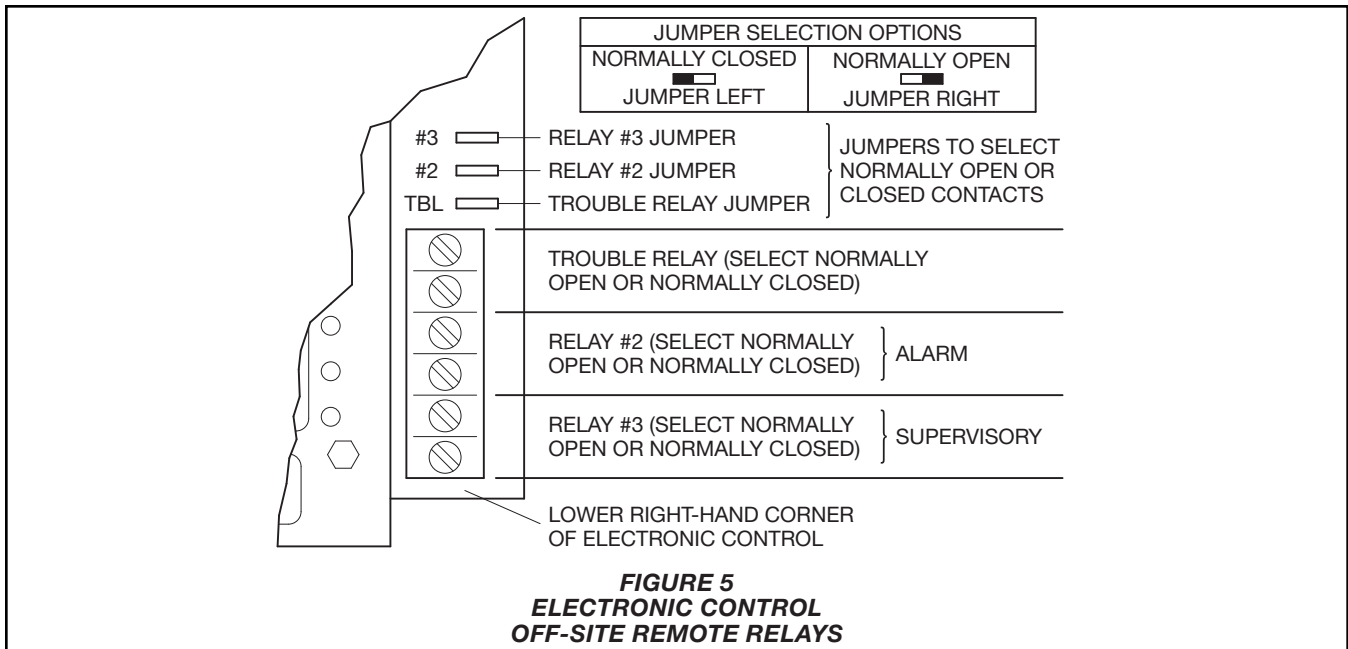

FIGURE 4
MODEL RCP-1 RESIDENTIAL CONTROL PANEL
ELECTRONIC CONTROL WIRING DIAGRAM



The owner responsible for the inspection, testing, and maintenance of their fire protection system and devices in compliance with this document, as well as with the applicable standards of the NATIONAL FIRE PROTECTION ASSOCIATION (e.g., NFPA 25), in addition to the requirements of any authority having jurisdiction. Contact the installing contractor or product manufacturer with any questions.

Automatic sprinkler systems are recommended to be inspected, tested, and maintained by a qualified Inspection Service in accordance with local requirements and/or national codes.

Inspection/Test Procedure

The Model RCP-1 Panel can be inspected and tested without having to flow water into the system piping. The inspection and testing, in accordance with the requirements of NFPA 25, must be performed annually.

General Inspection/Test

Step 1. Verify the Air Pressure Gauge indicates a system air pressure of 10 to 14 psi.

Step 2. Verify the Operator Interface of the Electronic Control only indicates a green light for AC Power.

Step 3. Open and then close the Flow Test Valve. The Water Supply Gauge should drop to a previously noted residual pressure and then return to the normal static pressure.

Step 4. Perform a lamp test by pressing and holding the ACCEPT SIGNAL KEY for a duration of five seconds. Verify that all system LEDs are functioning.

Trip Test

Step 1. Close the System Control Valve and accept the supervisory alarm at the Operator Interface by pressing the ACCEPT SIGNAL KEY.

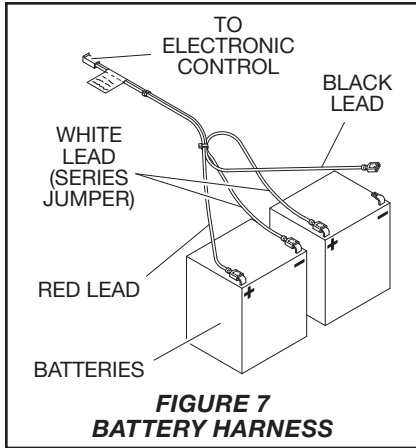

Step 2. Partially open the Drain Valve to relieve air pressure. When the system trips (releases), completely open the Drain Valve.

- Note that the Operator Interface IDC1 indicates alarm when the air pressure gauge indicates nominally 8 psi.
- Note that the Operator Interface indicates system released.
- Note that water is discharging from the drain line.

Step 3. Reset the Model RCP-1 Panel following the appropriate resetting instructions.

System Programming Mode Check
 If a malfunction of the Electronic Control is suspected, verify the pre-programming of the panel as follows:

Step 1. With reference to Figure 8, remove the Operator Interface card and reinsert it so that the SYSTEM PROGRAMMING MODE information listed on the card's back side faces front.

Step 2. Place the PROGRAM SWITCH (Ref. Figure 8) to the ON position and then momentarily press the ACCEPT SIGNAL KEY to accept the resulting programming mode trouble.

Step 3. Press the ACCEPT SIGNAL KEY to scroll through MODES 1 through 10 and verify that the POSITION 1 through 10 lights up as follows:

- MODE 1: POSITION 6 for Dry Pipe
- MODE 1/3: POSITION 1
- MODE 2: POSITION 1 for Class B Initiating Circuit Style
- MODE 3: POSITION 1 for 0-Second Automatic Time Release Delay
- MODE 4: POSITION 1 for No RAC Cutout Timer
- MODE 5: POSITION 1 for 0 Second Manual Release Time Delay

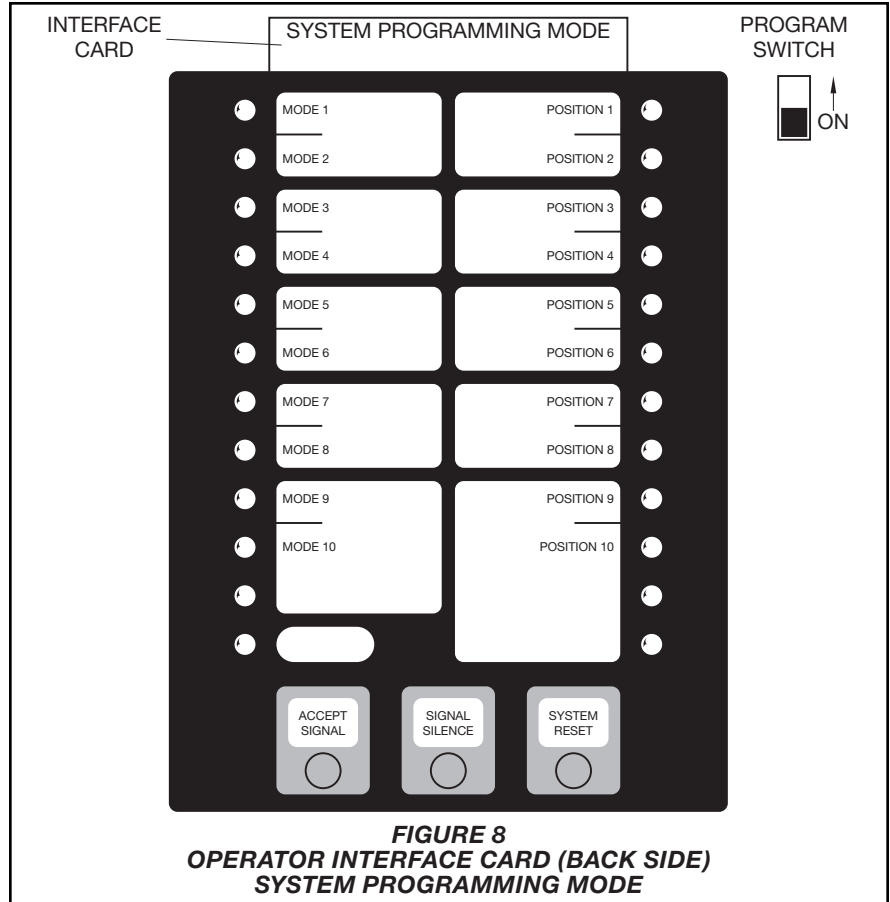

- MODE 6: POSITION 1 for Immediate Abort Release Time Delay
- MODE 7: POSITION 1 for Temporal NAC Coding
- MODE 8: POSITION 1 for On Until Silenced NAC Operation
- MODE 9: POSITION 2 for Supervisory Latching
- MODE 10: POSITION 3 for Standard (LED-Piezo) Supervisory Notification

Step 4. If a POSITION must be corrected for a given MODE number, press the SYSTEM RESET KEY to scroll through the positions. When at the correct position, press the ACCEPT SIGNAL KEY to confirm a selection and scroll to the next MODE number.

Step 5. Upon completing the programming check, place the PROGRAM SWITCH in the OFF position, and then return the Operator Interface card to its normal position.

NOTICE
Exercise care to ensure that all MODES are restored to their proper settings.

Ordering Procedure

Contact your local distributor for availability. When placing an order, indicate the full product name, including description and Part Number (P/N).

Model RCP-1 Panel
 Specify: (size) Model RCP-1 Residential Control Panel and P/N (specify):

- 1 in. 52-310-2-601
- 1-1/2 in. 52-310-2-602

Separately Ordered Parts
 Specify: Bezel for use with the Model RCP-1 Residential Control Panel, P/N 52-310-2-603

Replacement Parts
 Specify: 8.0 Amp Batteries BT-80 for use with the Model RCP-1 Residential Control Panel, P/N 2656