



Series TY-B — 5.6 and 8.0 K-factor Upright and Pendent Intermediate Level Sprinklers Standard Response

General Description

The Series TY-B, 5.6 and 8.0 K-factor Upright and Pendent Intermediate Level Sprinklers described in this data sheet are automatic sprinklers of the “standard response” 5 mm frangible bulb type. They are “standard spray” sprinklers intended for use in fire sprinkler systems designed in accordance with the standard installation rules recognized by the applicable Listing or Approval agency (e.g., UL Listing is based on NFPA requirements). Both the Pendent and Upright Sprinklers produce a hemispherical water distribution pattern below the deflector.

Intermediate Level Sprinklers are primarily designed for use in rack storage sprinkler systems where their thermally sensitive elements must be shielded from the water spray of higher elevation sprinklers that could operate earlier during a fire. Intermediate Level Sprinklers are also used in other applications such as beneath open gridded catwalks.

Corrosion resistant coatings, where applicable, are utilized to extend the life of copper alloy sprinklers beyond that which would otherwise be obtained when exposed to corrosive atmospheres. Although corrosion resistant coated sprinklers have passed the standard corrosion tests of the applicable approval agencies, the testing is not representative of all possible cor-

rosive atmospheres. Consequently, it is recommended that the end user be consulted with respect to the suitability of these coatings for any given corrosive environment. The effects of ambient temperature, concentration of chemicals, and gas/chemical velocity, should be considered, as a minimum, along with the corrosive nature of the chemical to which the sprinklers will be exposed.

NOTICE

The Series TY-B Sprinklers described herein must be installed and maintained in compliance with this document, as well as with the applicable standards of the National Fire Protection Association, in addition to the standards of any other authorities having jurisdiction. Failure to do so may impair the performance of these devices.

The owner is responsible for maintaining their fire protection system and devices in proper operating condition. The installing contractor or sprinkler manufacturer should be contacted with any questions.

Sprinkler Identification Numbers

- TY3153 . . . Upright 5.6K, 1/2 in. NPT
- TY3251 . . . Pendent 5.6K, 1/2 in. NPT
- TY4153 . . . Upright 8.0K, 3/4 in. NPT
- TY4251 . . . Pendent 8.0K, 3/4 in. NPT

Technical Data

Approvals

UL and C-UL Listed
FM and NYC Approved

(Refer to Table A for complete approval information including corrosion resistant status.)

Maximum Working Pressure

175 psi (12,1 bar)

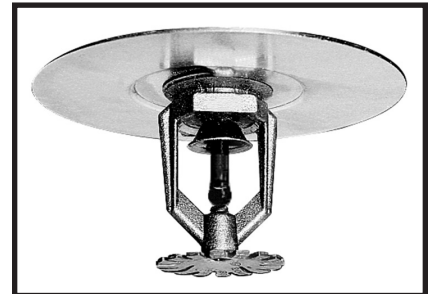

Discharge Coefficient

K = 5.6 GPM/psi^{1/2} (80,6 LPM/bar^{1/2})
K = 8.0 GPM/psi^{1/2} (115,2 LPM/bar^{1/2})

Temperature Ratings

Refer to Table A

Finishes

Sprinkler: Refer to Table A

Physical Characteristics

Frame	Bronze
Button	Brass/Copper
Sealing Assembly	Beryllium Nickel w/TEFLON
Bulb	Glass
Compression Screw	Bronze
Deflector	Copper
Shield	Plated Steel

IMPORTANT

Refer to Technical Data Sheet TFP2300 for warnings pertaining to regulatory and health information.

Always refer to Technical Data Sheet TFP700 for the “INSTALLER WARNING” that provides cautions with respect to handling and installation of sprinkler systems and components. Improper handling and installation can permanently damage a sprinkler system or its components and cause the sprinkler to fail to operate in a fire situation or cause it to operate prematurely.

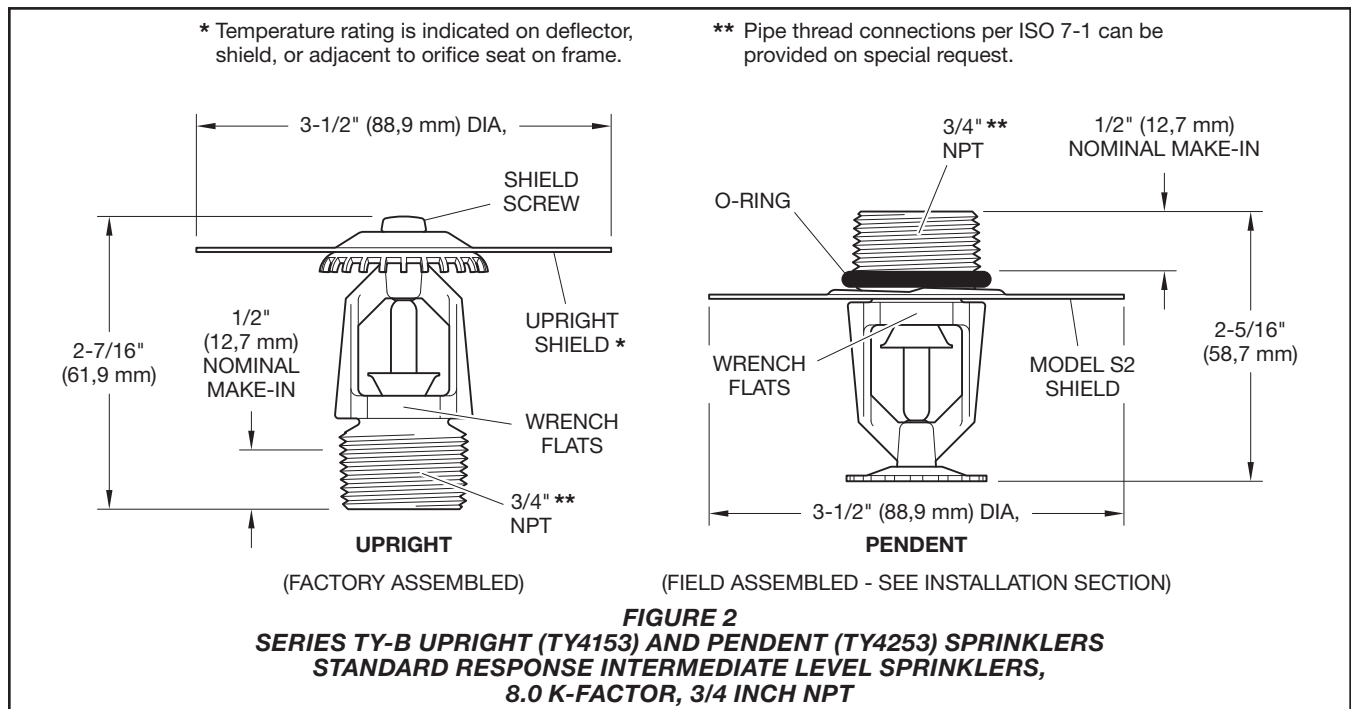
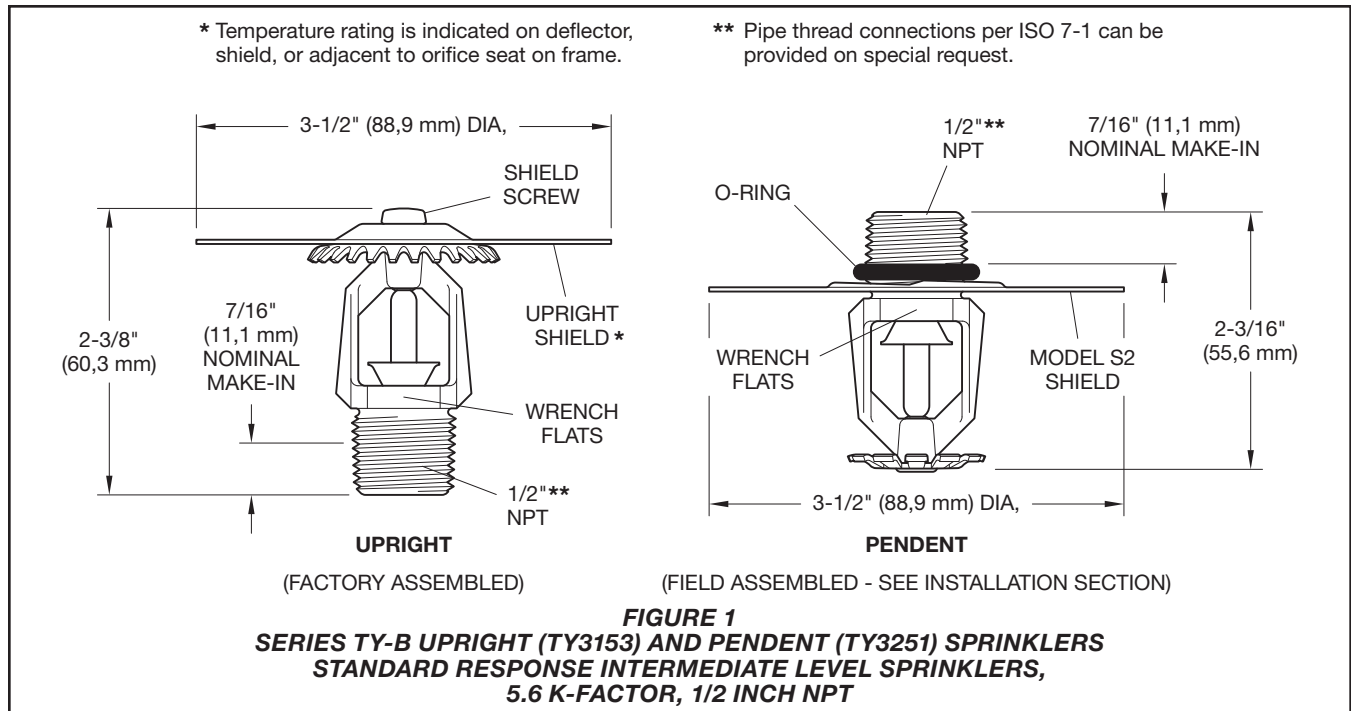

K	TYPE	TEMP.	BULB LIQUID	SPRINKLER FINISH (SEE NOTE 5)			
				NATURAL BRASS**	LEAD COATED	WAX COATED**	WAX OVER LEAD COATED**
5.6 1/2 in. NPT	UPRIGHT (TY3153)	135°F (57°C)	Orange	1, 2, 3, 4	1, 2, 3, 4	N/A	
		155°F (68°C)	Red				
		175°F (79°C)	Yellow				
		200°F (93°C)	Green				
		286°F (141°C)	Blue				
		360°F (182°C)	Mauve				
	PENDENT (TY3251)	135°F (57°C)	Orange	1, 2, 3, 4	1**, 2**, 3**, 4**	1, 2, 3, 4	
		155°F (68°C)	Red				
		175°F (79°C)	Yellow				
		200°F (93°C)	Green			1*, 2*, 3*, 4*	
		286°F (141°C)	Blue			N/A	
		360°F (182°C)	Mauve			N/A	
8.0 3/4 in. NPT	UPRIGHT (TY4153)	135°F (57°C)	Orange	1, 2, 3, 4	1, 2, 3, 4	N/A	
		155°F (68°C)	Red				
		175°F (79°C)	Yellow				
		200°F (93°C)	Green				
		286°F (141°C)	Blue				
		360°F (182°C)	Mauve				
	PENDENT (TY4251)	135°F (57°C)	Orange	1, 2, 3, 4	1**, 2**, 3**, 4**	1, 2, 3, 4	
		155°F (68°C)	Red				
		175°F (79°C)	Yellow				
		200°F (93°C)	Green			1*, 2*, 3*, 4*	
		286°F (141°C)	Blue			N/A	
		360°F (182°C)	Mauve			N/A	

NOTES:

1. UL Listed.
 2. C-UL Listed.
 3. FM Approved.
 4. Approved by the City of New York under MEA 354-01-E.
 5. Where Lead Coated, Wax Coated, and Wax over Lead Coated Sprinklers are noted to be UL and C-UL Listed, the sprinklers are UL and C-UL Listed as Corrosion Resistant Sprinklers. Where Lead Coated, Wax Coated, and Wax over Lead Coated Sprinklers are noted to be FM Approved, the sprinklers are FM Approved as Corrosion Resistant Sprinklers.
- *150°F (66°C) Maximum Ceiling Temperature.
 ** With Zinc Plated Shield.
 N/A: Not Available

TABLE A
LABORATORY LISTINGS AND APPROVALS

Operation

The glass bulb contains a fluid which expands when exposed to heat. When the rated temperature is reached, the fluid expands sufficiently to shatter the glass bulb, allowing the sprinkler to activate and water to flow.

Design Criteria

The Series TY-B Pendent and Upright Intermediate Level Sprinklers are intended for fire protection systems designed in accordance with the standard installation rules recognized by the applicable Listing or Approval agency (e.g., UL Listing is based on the requirements of NFPA 13, and FM Approval is based on the requirements of FM's Loss Prevention Data Sheets).

Installation

The Series TY-B, Upright and Pendent Intermediate Level Sprinklers must be installed in accordance with this section.

General Instructions

Do not install any bulb type sprinkler if the bulb is cracked or there is a loss of liquid from the bulb. With the sprinkler held horizontally, a small air bubble should be present. The diameter of the air bubble is approximately 1/16 in. (1,6 mm) for the 135°F (57°C) to 3/32 in. (2,4 mm) for the 360°F (182°C) temperature ratings.

A leak tight 1/2 in. NPT sprinkler joint should be obtained with a torque of 7 to 14 lb-ft (9,5 to 19,0 N·m). A leak tight 3/4 in. NPT sprinkler joint should be obtained with a torque of 10 to 20 lb-ft (13,4 to 26,8 N·m). Higher levels of torque may distort the sprinkler inlet and cause leakage or impairment of the sprinkler.

Upright Sprinklers

The Series TY-B Intermediate Level Upright Sprinklers must be installed in accordance with the following instructions.

Step 1. With pipe thread sealant applied to the pipe threads, hand tighten the sprinkler into the sprinkler fitting.

Step 2. Tighten the sprinkler into the sprinkler fitting using only the W-Type 6 Sprinkler Wrench (refer to Figure 3), except that an 8 in. or 10 in. adjustable Crescent wrench is to be used for wax coated sprinklers. With reference to Figure 1 or 2, the W-Type 6 Sprinkler Wrench or the Crescent wrench, as applicable, is to be applied to the wrench flats.

Pendent Sprinklers

The Series TY-B Intermediate Level Pendent Sprinklers must be installed in accordance with the following instructions.

Step A. Thread the S2 Shield onto the sprinkler threads with the stamped markings toward the deflector and just to the end of the threads. The final assembly step is easier to accomplish if the Shield is not disengaged by continuing to turn the Shield past the threads.

Step B. Roll the O-Ring over the sprinkler threads until it seats against the Shield.

Step C. With pipe thread sealant applied to the pipe threads, hand tighten the sprinkler into the sprinkler fitting.

Step D. Tighten the sprinkler into the sprinkler fitting using only the W-Type 6 Sprinkler Wrench (refer to Figure 3). With reference to Figure 1 or 2, the W-Type 6 Sprinkler Wrench is to be applied to the wrench flats.

Step E. Rotate the S2 Shield clockwise (looking up) so that it slightly compresses the O-Ring between the Shield and sprinkler fitting.

Wax Coated Sprinklers

When installing wax coated sprinklers with the adjustable Crescent wrench, additional care needs to be exercised to prevent damage to the wax coating on the sprinkler wrench flats or frame arms and, consequently, exposure of bare metal to the corrosive environment. The jaws of the wrench should be opened sufficiently wide to pass over the wrench flats without damaging the wax coating. Before wrench tightening the sprinkler, the jaws of the wrench are to be adjusted to just contact the sprinkler wrenching flanges. After wrench tightening the sprinkler, loosen the wrench jaws before removing the wrench.

After installation, the sprinkler wrench flats and frame arms must be inspected and the wax coating retouched (repaired) whenever the coating has been damaged and bare metal is exposed. The wax coating on the wrench flats can be retouched by gently applying a heated 1/8 in. diameter steel rod to the areas of wax that have been damaged, to smooth it back over areas where bare metal is exposed.

NOTES

Only retouching of the wax coating applied to the wrench flats and frame arms is permitted, and the retouching is to be performed only at the time of the initial sprinkler installation.

The steel rod should be heated only to the point at which it can begin to melt the wax, and appropriate precautions need to be taken, when handling the heated rod, in order to prevent the installer from being burned.

If attempts to retouch the wax coating with complete coverage are unsuccessful, additional wax can be ordered

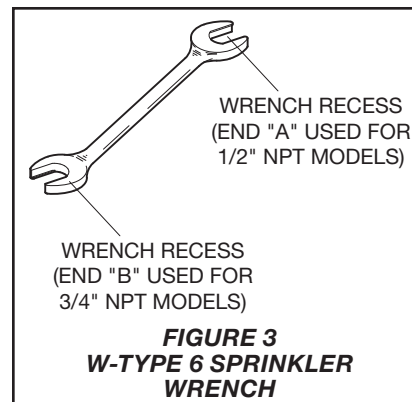

in the form of a wax stick (the end of which is color coded). Only the correct color coded wax is to be used, and retouching of wrench flats and frame arms is only permitted at the time of initial sprinkler installation. With the steel rod heated as previously described, touch the rod to the area requiring additional wax with the rod angled downward, and then touch the wax stick to the rod approximately one-half inch away from the area requiring retouching. The wax will melt and run down onto the sprinkler.

Care and Maintenance

The Series TY-B, Upright and Pendent Intermediate Level Sprinklers must be maintained and serviced in accordance with this section.

Before closing a fire protection system main control valve for maintenance work on the fire protection system that it controls, permission to shut down the affected fire protection system must be obtained from the proper authorities and all personnel who may be affected by this action must be notified.

Sprinklers that are found to be leaking or exhibiting visible signs of corrosion must be replaced.

Automatic sprinklers must never be painted, plated, coated or otherwise altered after leaving the factory. Modified sprinklers must be replaced. Sprinklers that have been exposed to corrosive products of combustion, but have not operated, should be replaced if they cannot be completely cleaned by wiping the sprinkler with a cloth or by brushing it with a soft bristle brush.

Care must be exercised to avoid damage to the sprinklers before, during, and after installation. Sprinklers damaged by dropping, striking, wrench twist/slippage, or the like, must be replaced. Also, replace any sprinkler that has a cracked bulb or that has lost liquid from its bulb (refer to Installation Section).

The owner is responsible for the inspection, testing, and maintenance of their fire protection system and devices in compliance with this document, as well as with the applicable standards of the National Fire Protection Association (e.g., NFPA 25), in addition to the standards of any other authorities having jurisdiction. The installing contractor or sprinkler manufacturer should be contacted relative to any questions.

It is recommended that automatic sprinkler systems be inspected, tested, and maintained by a qualified Inspection Service in accordance with local requirements and/or national code.

Ordering Procedure

Contact your local distributor for availability. When placing an order, indicate the full product name and Part Numbers (P/N).

Upright Sprinkler Assemblies with Shield and NPT Thread Connections

Specify: Series TY-B (specify SIN), (specify K-factor), Upright Intermediate Level Sprinkler Standard Response, (specify) temperature rating, with (specify finish or coating), P/N (specify from Table B)

Pendent Sprinkler Assemblies with (Shield Ordered Separately) and NPT Thread Connections

Specify: Series TY-B (Specify SIN), (specify K-factor), Pendent Sprinkler Standard Response, (specify) temperature rating, with (specify finish or coating), P/N (specify from Table C)

Model S2 Pendent Shield & O-Ring

Specify: S2 Pendent Shield & O-Ring for use with (specify 1/2" NPT or 3/4" NPT) Series TY-B Pendent Sprinklers, P/N (specify)

1/2 in. NPT S2 Pendent
Shield & O-Ring P/N 56-070-9-332

3/4 in. NPT S2 Pendent
Shield & O-Ring P/N 56-070-9-342

Sprinkler Wrench

Specify: W-Type 6 Sprinkler Wrench, P/N 56-000-6-387

Wax Sticks (for retouching wrench damaged wax coating)

Specify: (Specify color) color coded Wax Stick for retouching (specify) temperature rating temperature rated Series TY-B Sprinklers, P/N (specify)

Black for 135°F (57°C) . . P/N 56-065-1-135
Red for 155°F (68°C) . . P/N 56-065-1-155
Yellow for 175°F (79°C) . P/N 56-065-1-175
Blue for 200°F (93°C)
and 286°F (141°C) P/N 56-065-1-286

NOTES

Each wax stick is suitable for retouching up to twenty-five sprinklers.

The wax used for 286°F (141°C) sprinklers is the same as for 200°F (93°C) sprinklers, and, therefore, the 286°F (141°C) sprinkler is limited to the same maximum ceiling temperature as the 200°F (93°C) sprinkler (i.e., 150°F (66°C).

P/N 57 - XXX - X - XXX

		SIN	SPRINKLER		TEMPERATURE RATING	
533	5.6K UPRIGHT (1/2 in. NPT)	TY3153	1	NATURAL BRASS	135	135°F (57°C)
543	8.0K UPRIGHT (3/4 in. NPT)	TY4153	7	LEAD COATED	155	155°F (68°C)
					175	175°F (79°C)
					200	200°F (93°C)
					286	286°F (141°C)
					360	360°F (182°C)

TABLE B
SERIES TY-B UPRIGHT INTERMEDIATE LEVEL SPRINKLERS
PART NUMBER SELECTION
(Upright Shield Included With Sprinkler)

P/N 57 - XXX - X - XXX

		SIN	SPRINKLER		TEMPERATURE RATING	
571	5.6K PENDENT (1/2 in. NPT)	TY3251	1	NATURAL BRASS	135	135°F (57°C)
591	8.0K PENDENT (3/4 in. NPT)	TY4251	6	WAX COATED 286°F (141°C) MAXIMUM	155	155°F (68°C)
			7	LEAD COATED	175	175°F (79°C)
			8	WAX OVER LEAD 286°F (141°C) MAXIMUM	200	200°F (93°C)
					286	286°F (141°C)
					360	360°F (182°C)

TABLE C
SERIES TY-B PENDENT SPRINKLERS
PART NUMBER SELECTION
(Model S2 Pendent Shield & O-Ring Must Be Separately Ordered)