



# Model CHEC—8.0 K-factor Concealed Horizontal Extended Coverage Quick Response Light Hazard, Sidewall Sprinklers

## General Description

The TYCO Model CHEC 8.0 K-factor, Concealed Horizontal Extended Coverage Quick Response Light Hazard, Sidewall Sprinklers are decorative, 3 mm bulb type sprinklers featuring a unique cover plate designed to conceal the sprinkler. It is the best choice for architecturally sensitive areas such as dormitories, hotel rooms, reception areas, office buildings, banquet facilities, conference rooms, and hospitals.

The soft contour of the cover plate optimizes a low profile while blending in with surrounding surfaces. The plate, while maintaining a fast response sensitivity has been specifically designed without vent holes to increase its aesthetic appeal while helping to avoid objects from being hung from the sprinkler, such as garment bags and clothes hangers, that might otherwise cause an inadvertent operation.

They are designed for installation along a wall or the side of a beam and beneath a smooth and level ceiling. Horizontal sidewall sprinklers are commonly used in lieu of pendent or upright sprinklers because of aesthetics or building construction considerations where piping across the ceiling is not desirable.

They are intended for use in automatic sprinkler systems designed in accordance with standard installation rules, for example NFPA 13, for light hazard occupancies. The fast response

thermal sensitivity rating of the Model CHEC Sprinklers provides for a quick response extended coverage rating up to a 16 ft x 16 ft coverage area.

Each unit includes a Cover Plate Assembly that conceals the sprinkler operating components. The separable two-piece design of the Cover Plate and Support Cup Assemblies allows installation of the sprinklers and pressure testing of the fire protection system prior to the installation of the wall or application of a finish coating.

Also, the separable “push-on and thread-off” two-piece design of the sprinkler provides for 1/2 in. (12,7 mm) of horizontal adjustment.

The Model CHEC Sprinklers are shipped with a Protective Cap. The Protective Cap is temporarily removed for installation, and it must be replaced to help protect the sprinkler while the wall is being plastered, wallpapered, or painted. When the wall installation is complete the Protective Cap must be removed and the Cover Plate Assembly installed. The Protective Cap must be removed to ensure proper performance of the sprinklers.

### NOTICE

*The TYCO Model CHEC 8.0 K-factor, Concealed Horizontal Extended Coverage Quick Response Light Hazard, Sidewall Sprinklers described herein must be installed and maintained in compliance with this document and with the applicable standards of the National Fire Protection Association, in addition to the standards of any authorities having jurisdiction. Failure to do so may impair the performance of these devices.*

*The owner is responsible for maintaining their fire protection system and devices in proper operating condition. Contact the installing contractor or product manufacturer with any questions.*



## Sprinkler Identification Number

TY4332

## Technical Data

### Approvals

UL and C-UL Listed  
NYC Approved under MEA 177-03-E

**Note:** *The listings apply only to the service conditions indicated in the Design Criteria section.*

**Maximum Working Pressure**  
175 psi (12,1 bar)

**Discharge Coefficient**  
K=8.0 GPM/psi<sup>1/2</sup> (115,2 LPM/bar<sup>1/2</sup>)

**Temperature Rating**  
155°F (68°C) Sprinkler with  
139°F (59°C) Cover Plate

**Horizontal Adjustment**  
1/2 in. (12,7 mm)

### Finishes

Refer to the Ordering Procedure section

### Physical Characteristics

Frame	.....	Bronze
Button	.....	Bronze
Button Spring	.....	Stainless Steel
Sealing Assembly	.....	Beryllium Nickel w/TEFLON
Bulb, 3 mm Diameter	.....	Glass
Deflector	.....	Copper
Compression Screw	.....	Brass
Support Cup	.....	Steel
Retainer	.....	Brass
Cover Plate	.....	Brass
Cover Plate Ejection Spring	.....	Stainless Steel

### IMPORTANT

Refer to Technical Data Sheet TFP2300 for warnings pertaining to regulatory and health information.

Always refer to Technical Data Sheet TFP700 for the “INSTALLER WARNING” that provides cautions with respect to handling and installation of sprinkler systems and components. Improper handling and installation can permanently damage a sprinkler system or its components and cause the sprinkler to fail to operate in a fire situation or cause it to operate prematurely.

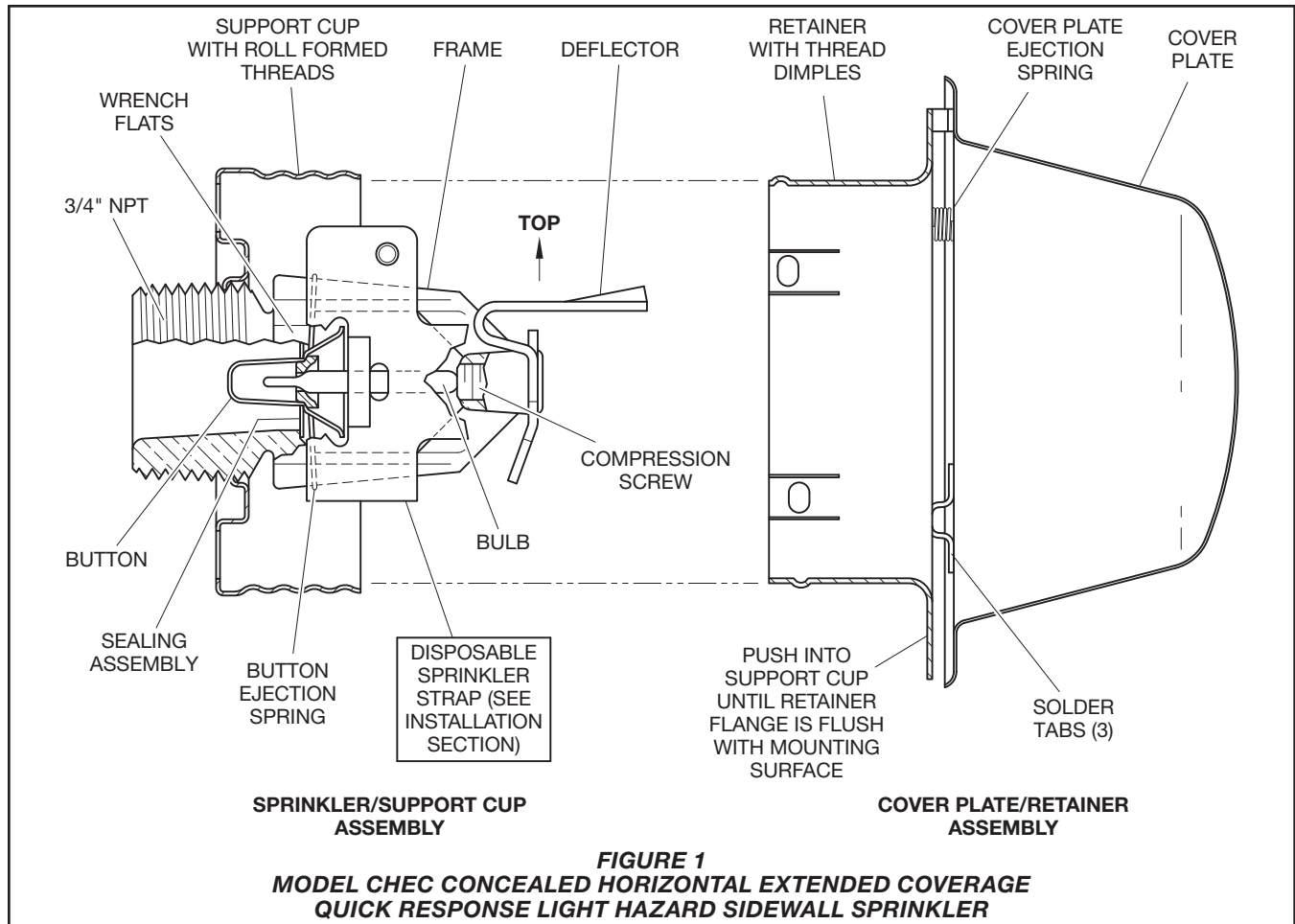

Response Rating	Coverage Area <sup>1</sup> Ft x Ft (m x m)	Minimum Flow <sup>2</sup> GPM (LPM)	Minimum Pressure <sup>2</sup> PSI (bar)	Deflector-To-Ceiling Distance <sup>3</sup> In. (mm)	Sprinkler Temperature Rating, °F	Lateral Minimum Spacing <sup>4</sup> Ft. (m)
Quick	16 x 14 (4,9 x 4,3)	26 (98)	10.6 (0,73)	4 to 12 (100 to 300)	155	10 (3,1)
Quick	16 x 16 (4,9 x 4,9)	26 (98)	10.6 (0,73)	4 to 12 (100 to 300)	155	10 (3,1)

**NOTES**

1. Backwall (where sprinkler is located) by sidewall (length of throw).
2. Requirement is based on minimum flow in GPM from each sprinkler. The indicated residual pressures are based on the nominal K-factor.
3. The centerline of the sprinkler waterway is located 7/16 in. (11,1 mm) below the deflector (Ref. Figure 2).
4. Minimum spacing is for lateral distance between sprinklers located along a single wall. Otherwise adjacent sprinklers (i.e., sidewall sprinklers on an adjacent wall, on an opposite wall, or pendent sprinklers) must be located outside of the maximum listed protection area of the extended coverage sidewall sprinkler being utilized.

**TABLE A**  
**UL AND C-UL LISTING COVERAGE AND FLOW RATE CRITERIA**

## Operation

When exposed to heat from a fire, the Cover Plate, which is soldered to the Retainer at three points, falls away to expose the Sprinkler Assembly. The glass bulb contains a fluid that expands when exposed to heat. When the rated temperature is reached, the fluid expands sufficiently to shatter the glass bulb, activating the sprinkler and allowing water to flow.

## Design Criteria

The TYCO Model CHEC 8.0 K-factor, Concealed Horizontal Extended Coverage Quick Response Light Hazard, Sidewall Sprinklers are UL and C-UL Listed for use in light hazard occupancies, using the design criteria in Table A, in addition to the requirements

specified in the current NFPA 13 for extended coverage sidewall sprinklers.

The Model CHEC Sprinklers are only listed and approved with the Model CHEC Cover Plates having a factory applied finish.

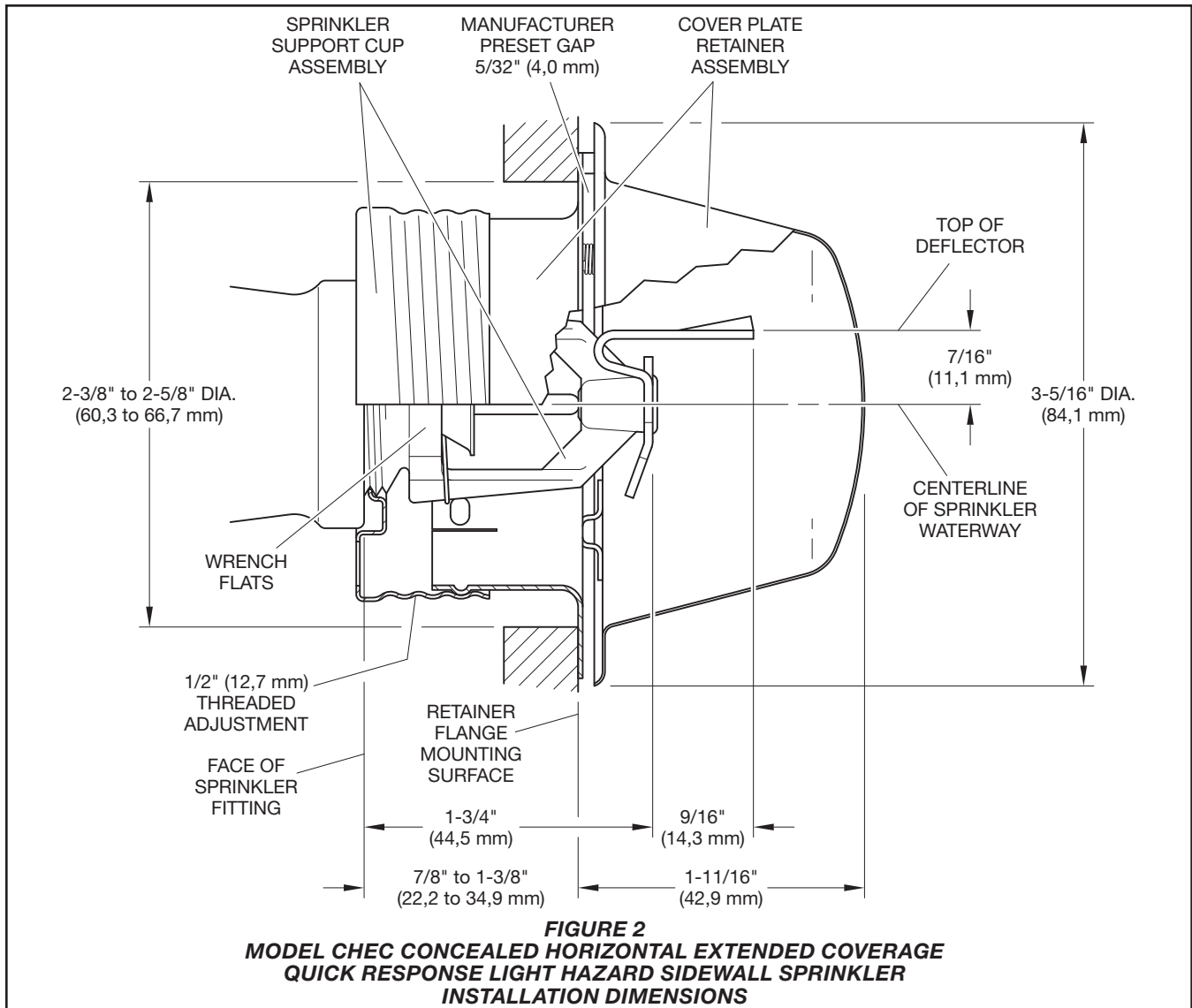

## Installation

The TYCO Model CHEC 8.0 K-factor, Concealed Horizontal Extended Coverage Quick Response Light Hazard, Sidewall Sprinklers must be installed in accordance with this section.

### General Instructions

Do not install any bulb type sprinkler if the bulb is cracked or there is a loss of liquid from the bulb. With the sprinkler held horizontally, a small air bubble should be present. The diameter of the air bubble is approximately 1/16 in. (1,6 mm).

A 3/4 in. NPT sprinkler joint should be obtained with a minimum to maximum torque of 10 to 20 lb-ft (13,4 to 26,8 N·m). Higher levels of torque may distort the sprinkler inlet with consequent leakage or impairment of the sprinkler.

Do not attempt to compensate for insufficient adjustment in the Sprinkler Assembly by under- or over-tightening the Sprinkler/Support Cup Assembly. Readjust the position of the sprinkler fitting to suit.

To install the Model CHEC Sprinklers, complete the following steps:

**Step 1.** The sprinkler must only be installed with its centerline perpendicular to the back wall and parallel to the ceiling. Face the word "Top" on the deflector towards the ceiling.

**Step 2.** Remove the Protective Cap.

### NOTICE

Do not remove the Sprinkler Strap (Figure 1) until the sprinkler system is to be placed in service.

**Step 3.** With pipe thread sealant applied to the pipe threads, hand-tighten the sprinkler into the sprinkler fitting.

**Step 4.** Wrench tighten the sprinkler using only the W-Type 7 Wrench (Ref. Figure 3). With reference to Figures 1 and 2, apply the wrench recess of the W-Type 7 Wrench to the Sprinkler Flats.

**Step 5.** With reference to Figure 4, replace the Protective Cap by pushing it inwards until it bottoms out against the Support Cup.

**Note:** The Protective Cap helps prevent damage to the Sprinkler while the wall is being plastered, wallpapered, or painted.

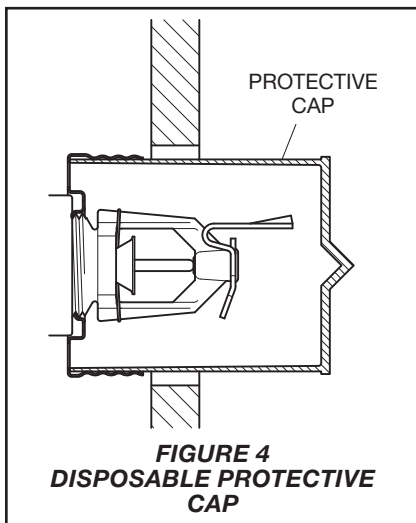
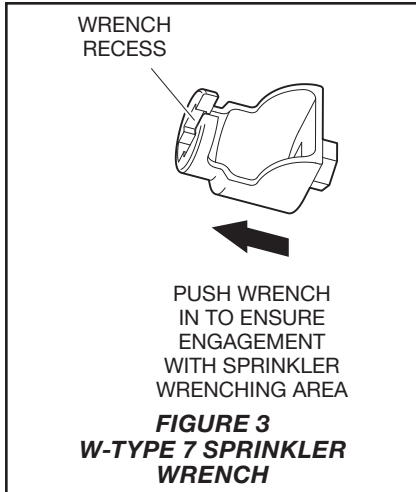

**NOTICE**

As long as the Sprinkler Strap (Figure 1) or the Protective Cap (Figure 4) remains in place, the system is considered to be “Out of Service”.

**Step 6.** After the wall has been completed with the nominal 2-1/2 in. (63,5 mm) diameter mounting hole and in preparation for installing the Cover Plate Assembly, remove and discard the Protective Cap and the Sprinkler Strap. If the Sprinkler has been damaged in any way including accidental over spray from finishing the wall, replace the entire Sprinkler/Support Cup Assembly.

**NOTICE**

Refer to Technical Data Sheet TFP700 regarding instructions for the removal of the Sprinkler Strap.

**Step 7.** Push the Cover Plate/Retainer Assembly into the Support Cup, and as necessary, make the final adjustment of the Cover Plate with respect to the wall by turning the Cover Plate/Retainer Assembly clockwise until its flange just comes in contact with the wall.

If it becomes necessary to remove the Cover Plate, it can be removed by unscrewing in a counter-clockwise direction.

If the Cover Plate/Retainer Assembly cannot be engaged with the Support Cup or the Cover Plate/Retainer Assembly cannot be engaged sufficiently to contact the wall, the Sprinkler Fitting must be repositioned.

## Care and Maintenance

The TYCO Model CHEC 8.0 K-factor, Concealed Horizontal Extended Coverage Quick Response Light Hazard, Sidewall Sprinklers must be maintained and serviced in accordance with this section.

Before closing a fire protection system main control valve for maintenance work on the fire protection system that it controls, permission to shut down the affected fire protection system must be obtained from the proper authorities and all personnel who may be affected by this action must be notified.

The owner is responsible for the inspection, testing, and maintenance of their fire protection system and devices in compliance with this document, as well as with the applicable standards of the National Fire Protection Association (e.g., NFPA 25), in addition to the standards of any other authorities having jurisdiction. Contact the installing contractor or product manufacturer with any questions.

Automatic sprinkler systems should be inspected, tested, and maintained by a qualified Inspection Service in accordance with local requirements and/or national codes.

When properly installed, there is a nominal 5/32 in. (4,0 mm) air gap between the lip of the Cover Plate and the wall, as shown in Figure 2. This air gap is necessary for proper operation of the sprinkler. If the wall is to be repainted after the installation of the Sprinkler, care must be exercised to ensure that the new paint does not seal off any of the air gap.

Factory painted Cover Plates must not be repainted. They should be replaced, if necessary, by factory painted units. Non-factory applied paint may adversely delay or prevent sprinkler operation in the event of a fire.

Do not pull the Cover Plate relative to the Enclosure. Separation may result.

Sprinklers that are found to be leaking or exhibiting visible signs of corrosion must be replaced.

Automatic sprinklers must never be painted, plated, coated or otherwise altered after leaving the factory. Modified or over heated sprinklers must be replaced.

Care must be exercised to avoid damage to the sprinklers -before, during, and after installation. Sprinklers damaged by dropping, striking, wrench twist/slippage, or the like, must be replaced. Also, replace any sprinkler that has a cracked bulb or that has lost liquid from its bulb. (Ref. Installation Section).

If a sprinkler must be removed, do not reinstall it or a replacement without reinstalling the Cover Plate Assembly. If a Cover Plate Assembly becomes dislodged during service, replace it immediately.

## Ordering Procedure

Contact your local distributor for availability. When placing an order, indicate the full product name and Part Number (P/N).

**Sprinkler Assembly**

Specify: Model CHEC, 8.0 K-factor, Concealed Horizontal Extended Coverage Quick Response Light Hazard, Sidewall Sprinkler, 155°F (68°C), P/N 51-396-1-155

**Separately Ordered Cover Plate**

Specify: 139°F (59°C) Model CHEC Cover Plate Assembly with Specify Finish, P/N (specify):

- Pure White (RAL 9010)\* . . . . .56-396-3-135
- Signal White (RAL 9003) . . . . .56-396-4-135
- Chrome. . . . .56-396-9-135
- Custom. . . . .56-396-X-135

\* Eastern Hemisphere sales only.

**Sprinkler Wrench**

Specify: W-Type 7 Sprinkler Wrench, P/N 56-850-4-001