



Series TY-L – 5.6 and 8.0 K-factor Upright, Pendent, and Recessed Pendent Sprinklers Standard Response, Standard Coverage

General Description

The TYCO Series TY-L 5.6 and 8.0 K-factor Upright, Pendent, and Recessed Pendent Sprinklers described herein are standard response, standard coverage, solder type spray sprinklers. They are designed for use in light, ordinary, and extra-hazard commercial occupancies such as banks, hotels, shopping malls, factories, refineries, and chemical plants.

The Series TY-L Recessed Pendent Sprinkler, where applicable, is intended for use in areas with a finished ceiling. It uses a two-piece Style 20 (1/2 in. NPT) or Style 30 (3/4 in. NPT) Recessed Escutcheon. The Recessed Escutcheon provides 1/4 in. (6,4 mm) of recessed adjustment or up to 1/2 in. (12,7 mm) of total adjustment from the flush pendent position. The adjustment provided by the Recessed Escutcheon reduces the accuracy to which the fixed pipe drops to the sprinklers must be cut.

Corrosion-resistant coatings, where applicable, are utilized to extend the life of copper alloy sprinklers beyond what would be obtained when exposed to corrosive atmospheres. Although corrosion-resistant coated sprinklers have passed the standard corrosion tests of the applicable approval agencies, the testing is not representative of all possible corrosive atmospheres. Conse-

IMPORTANT

Refer to Technical Data Sheet TFP2300 for warnings pertaining to regulatory and health information.

Always refer to Technical Data Sheet TFP700 for the "INSTALLER WARNING" that provides cautions with respect to handling and installation of sprinkler systems and components. Improper handling and installation can permanently damage a sprinkler system or its components and cause the sprinkler to fail to operate in a fire situation or cause it to operate prematurely.

quently, it is recommended that the end-user be consulted about the suitability of these coatings for any given corrosive environment. The effects of ambient temperature, concentration of chemicals, and gas/chemical velocity, should be considered as a minimum, along with the corrosive nature of the chemical to which the sprinklers will be exposed.

An intermediate level version of the Series TY-L Pendent Sprinkler can be obtained by utilizing the Series TY-L Pendent Sprinkler in combination with the Model S Shield.

NOTICE

The Series TY-L 5.6 and 8.0 K-factor Upright, Pendent, and Recessed Pendent Sprinklers described herein must be installed and maintained in compliance with this document, as well as with the applicable standards of the NATIONAL FIRE PROTECTION ASSOCIATION (NFPA), in addition to the standards of any other authorities having jurisdiction. Failure to do so may impair the performance of these devices.

The owner is responsible for maintaining their fire protection system and devices in proper operating condition. Contact the installing contractor or product manufacturer with any questions.

NFPA 13 prohibits installation of 1/2 inch NPT sprinklers with K-factors greater than 5.6 in new construction. They are intended for retrofit in existing sprinkler systems only.

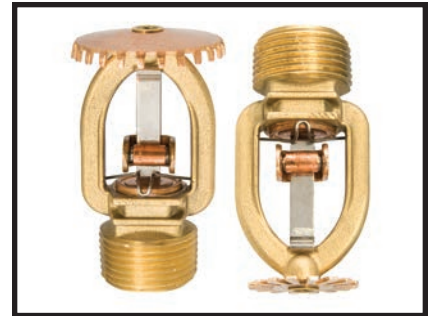

Sprinkler Identification Number (SIN)

TY3111 . . . Upright 5.6K, 1/2 in. NPT
TY3211 . . . Pendent 5.6K, 1/2 in. NPT
TY4111 . . . Upright 8.0K, 3/4 in. NPT
TY4211 . . . Pendent 8.0K, 3/4 in. NPT
TY4811 . . . Upright 8.0K, 1/2 in. NPT
TY4911 . . . Pendent 8.0K, 1/2 in. NPT

TY3111 is a re-designation for S1800 and G3111
TY3211 is a re-designation for S1801 and G3112
TY4111 is a re-designation for S1810 and G3101
TY4211 is a re-designation for S1811 and G3102
TY4811 is a re-designation for S1805
TY4911 is a re-designation for S1806

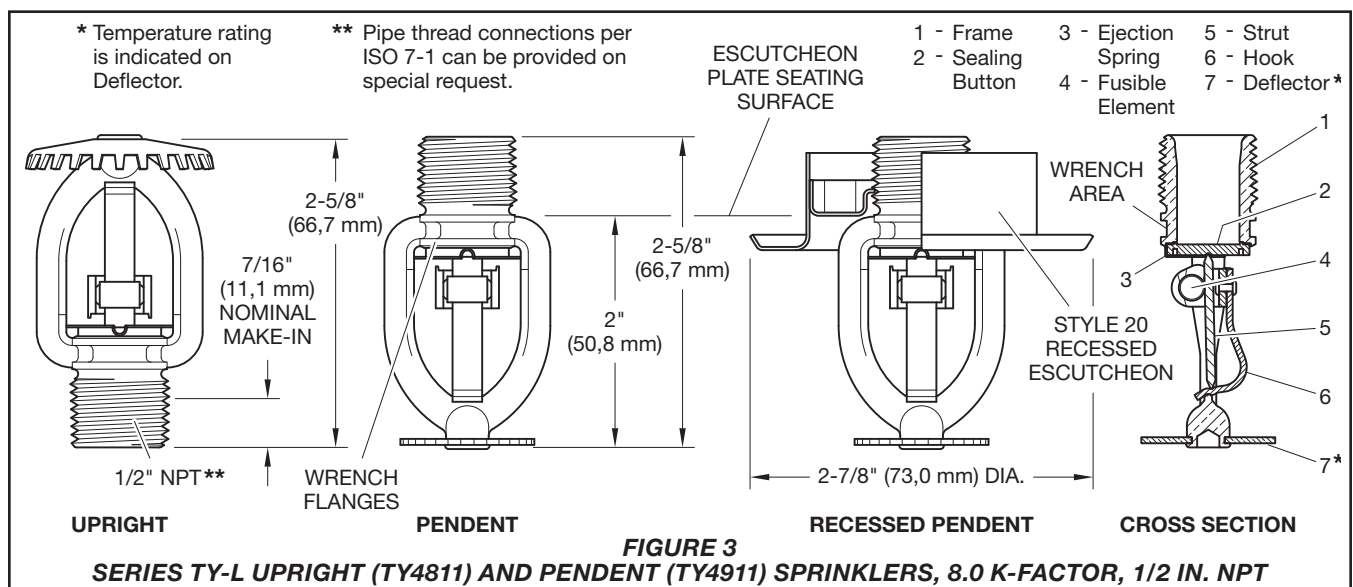
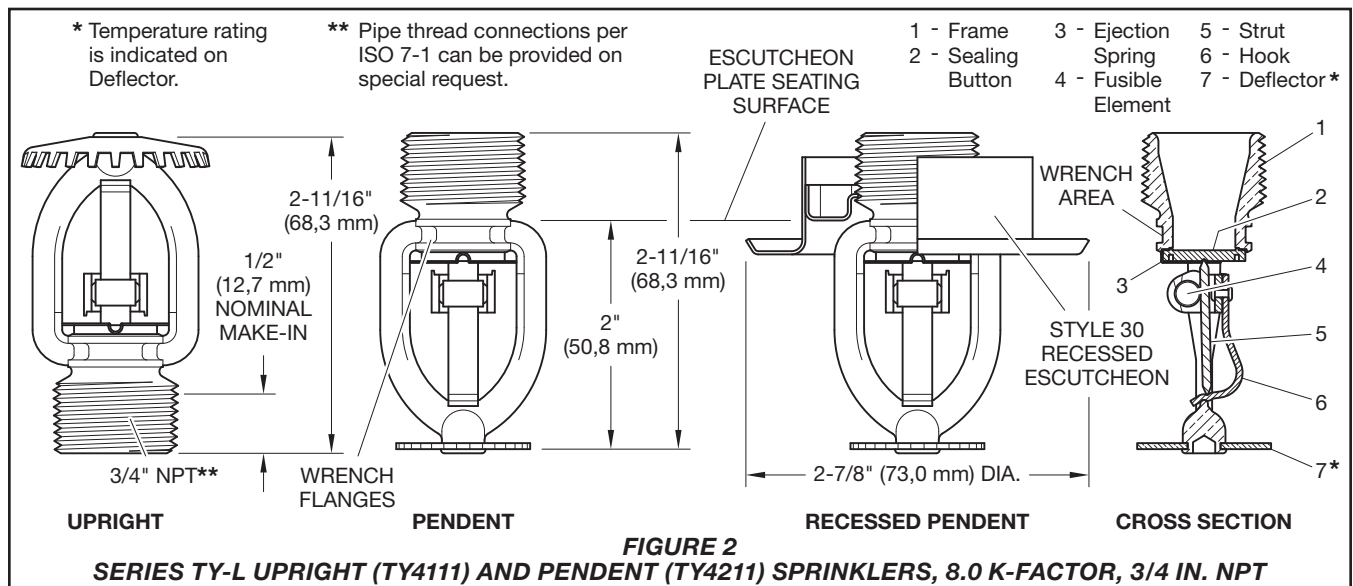
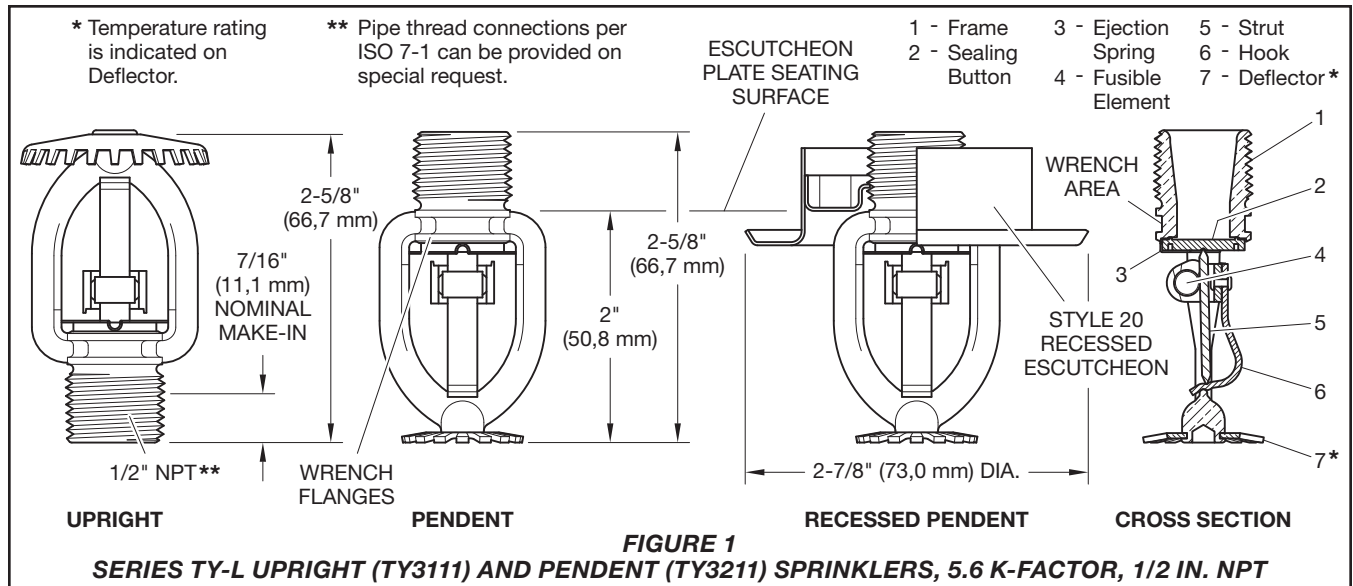

K	Type	Temp. Rating	Frame Color Code	Sprinkler Finish				
				Natural Brass	Chrome Plated	Lead Coated	Wax Coated	Wax Over Lead Coated
5.6 1/2 in. NPT	Pendent (TY3211) and Upright (TY3111)	165°F (74°C)	Unpainted	1, 2, 3, 5	1, 2, 3			
		212°F (100°C)	White					
		280°F (138°C)	Blue		1, 2	4	N/A	
	Recessed Pendent (TY3211 w/Style 20)	165°F (74°C)	Unpainted	1, 2, 3, 5	N/A ⁶			
212°F (100°C)		White	1, 2, 3, 5					
8.0 3/4 in. NPT	Pendent (TY4211)	165°F (74°C)	Unpainted	1, 2, 3	1, 2, 3			
		212°F (100°C)	White					
		280°F (138°C)	Blue		1, 2	4	N/A	
	Upright (TY4111)	165°F (74°C)	Unpainted	1, 2, 3, 5	1, 2, 3			
		212°F (100°C)	White					
		280°F (138°C)	Blue		1, 2	4	N/A	
Recessed Pendent (TY4211 w/Style 30)	165°F (74°C)	Unpainted	1, 2, 5	N/A				
	212°F (100°C)	White	1, 2, 5					
8.0 1/2 in. NPT	Pendent (TY4911) and Upright (TY4811)	165°F (74°C)	Unpainted	1, 2, 3, 5	1, 2, 3			
		212°F (100°C)	White					
		280°F (138°C)	Blue		1, 2	N/A		
	Recessed Pendent (TY4911 w/Style 20)	165°F (74°C)	Unpainted	1, 2	N/A			
212°F (100°C)		White	1, 2					

NOTES:
1. UL Listed
2. C-UL Listed
3. FM Approved
4. FM Approved for maximum 150°F (68°C) ambient temperatures
5. LPCB Approved (LPCB Ref. No. 094a/03)
6. Not Available (N/A)

TABLE A
LABORATORY LISTINGS AND APPROVALS

Technical Data

Approvals

UL and C-UL Listed
FM and LPCB Approved

Refer to Table A for complete approval information including corrosion resistant status.

Maximum Working Pressure

175 psi (12,1 bar)

Discharge Coefficient

K=5.6 GPM/psi^{1/2} (80,6 LPM/bar^{1/2})
K=8.0 GPM/psi^{1/2} (115,2 LPM/bar^{1/2})

Temperature Ratings

Refer to Table A

Finishes

Sprinkler: Refer to Table A Recessed

Escutcheon: White Coated, Chrome Plated, or Brass Plated

Physical Characteristics

FrameBrass
Sealing Button Bronze w/TEFLON
Ejection Spring Stainless Steel
Strut MONEL
Hook Bronze/MONEL
Deflector Bronze
Fusible ElementSolder, Copper,
Stainless Steel

Operation

A copper tube sealed by two stainless steel balls holds a fusible alloy. When the rated temperature is reached, the alloy melts and the balls are forced toward each other. This releases the tension mechanism and allows the sprinkler to operate.

Design Criteria

The TYCO Series TY-L 5.6 and 8.0 K-factor Upright, Pendent, and Recessed Pendent Sprinklers are intended for fire protection systems designed in accordance with the standard installation rules recognized by the applicable Listing or Approval agency, such as the UL Listing based on the requirements of NFPA 13 and FM Approval based on the requirements of FM Loss Prevention Data Sheets. Use only the Style 20 or 30 Recessed Escutcheon, as applicable, for recessed pendent installations.

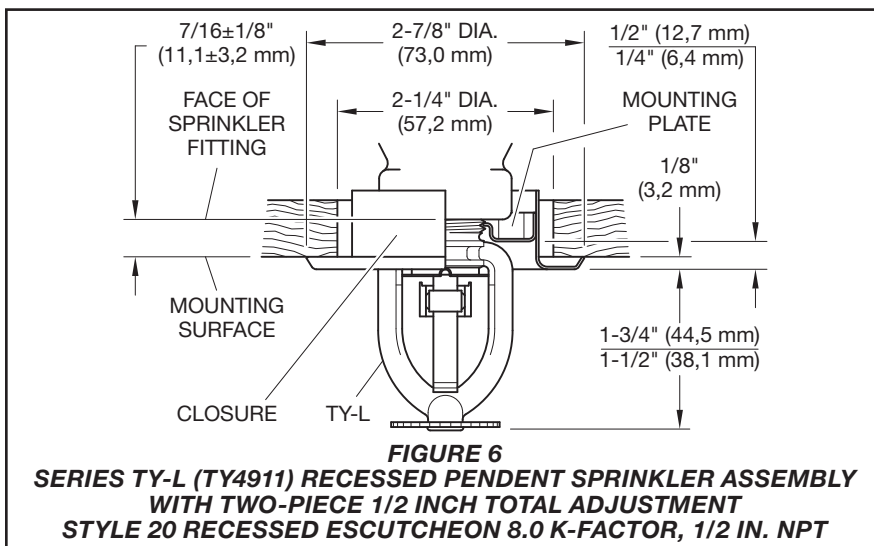
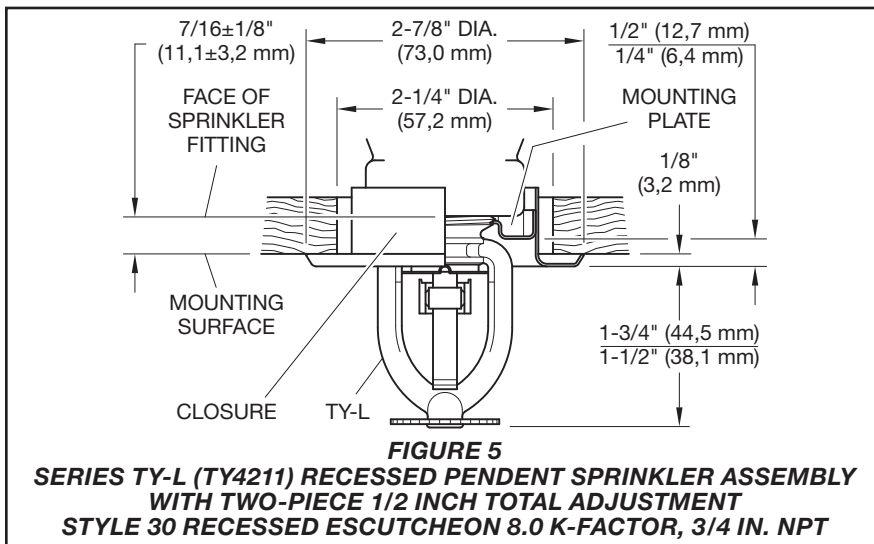
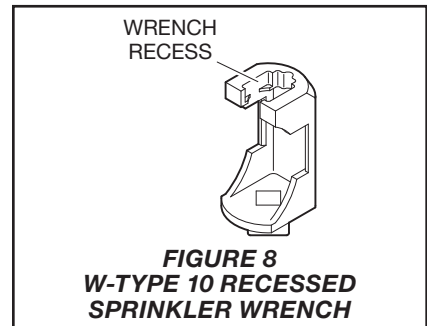
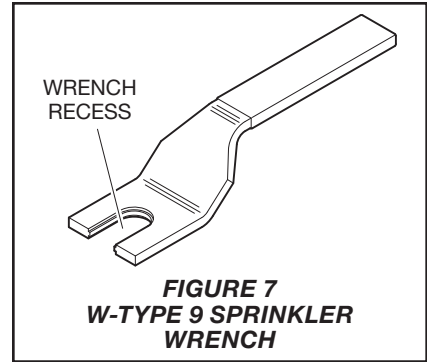
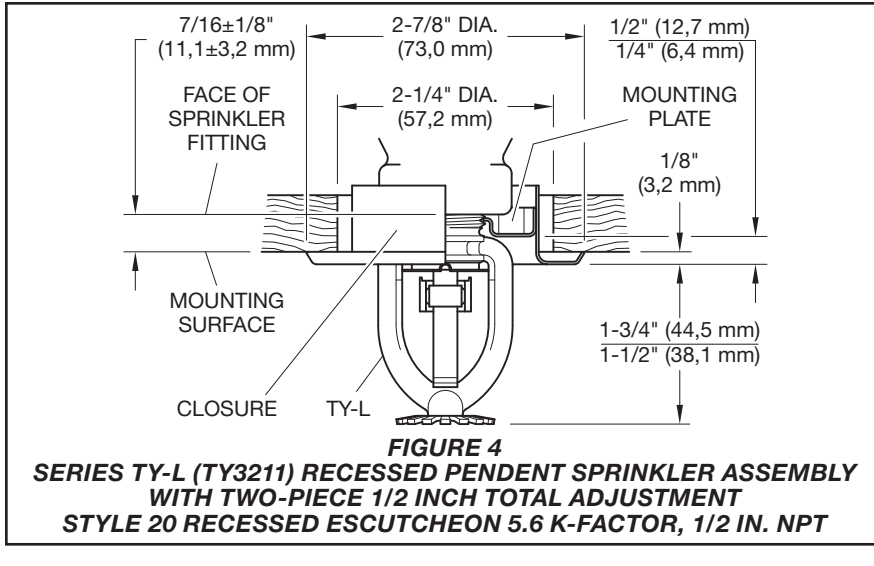

Installation

The TYCO Series TY-L 5.6 and 8.0 K-factor Upright, Pendent, and Recessed Pendent Sprinklers must be installed in accordance with this section.

General Instructions

A leak tight 1/2 in. NPT sprinkler joint should be obtained with a torque of 7 to 14 ft-lb (9,5 to 19,0 Nm). A leak-tight 3/4 in. NPT sprinkler joint should be obtained with a torque of 10 to 20 ft-lb (13,4 to 26,8 Nm). Higher levels of torque may distort the sprinkler inlet and cause leakage or impairment of the sprinkler.

Do not attempt to compensate for insufficient adjustment in the escutcheon plate by under- or over-tightening the sprinkler. Re-adjust the position of the sprinkler fitting to suit.

Series TY-L Upright and Pendent Sprinklers Installation

The Series TY-L Pendent and Upright Sprinklers must be installed in accordance with the following instructions:

Step 1. Install pendent sprinklers in the pendent position. Install upright sprinklers in the upright position.

Step 2. With pipe thread sealant applied to the pipe threads, hand-tighten the sprinkler into the sprinkler fitting.

Step 3. Tighten the sprinkler into the sprinkler fitting using only the W-Type 9 Sprinkler Wrench (Ref. Figure 7). For wax coated sprinklers, use an 8 or 10 in. adjustable Crescent wrench. With reference to Figures 1, 2, and 3, apply the W-Type 9 Sprinkler Wrench to the wrench area, or as applicable, apply the adjustable Crescent wrench to the wrenching flanges.

Wax Coated Sprinklers

When installing wax-coated sprinklers with the adjustable Crescent wrench, take care to prevent damage to the wax coating on the sprinkler wrench flats or frame arms and, consequently, exposure of bare metal to the corrosive environment:

- Open the jaws of the wrench sufficiently wide to pass over the wrench flats without damaging the wax coating.
- Before wrench tightening the sprinkler, adjust the jaws of the wrench to just contact the sprinkler flats.
- After wrench tightening the sprinkler, loosen the wrench jaws before removing the wrench.

After Installation

After installation, complete the following:

- Inspect the sprinkler wrench flats and frame arms and retouch (repair) the wax coating whenever the coating has been damaged and bare metal is exposed.
- Retouch the wax coating on the wrench flats by gently applying a heated 1/8 inch diameter steel rod to the damaged areas of the wax, to smooth it back over areas where bare metal is exposed.

NOTICE

Only retouching of the wax coating applied to the wrench flats and frame arms is permitted, and the retouching is to be performed only at the time of the initial sprinkler installation.

The steel rod should be heated only to the point it can begin to melt the wax, and appropriate precautions need to be taken when handling the heated rod to prevent the installer from being burned.

If attempts to retouch the wax coating with complete coverage are unsuccessful, additional wax can be ordered in the form of a wax stick, the end of which is color coded. Only the correct color coded wax is to be used, and retouching of wrench flats and frame arms is only permitted at the time of initial sprinkler installation.

With the steel rod heated as previously described, touch the rod to the area requiring additional wax with the rod angled downward, and then touch the wax stick to the rod approximately 1/2 in. (12,7 mm) away from the area requiring retouching. The wax will melt and run down onto the sprinkler.

Series TY-L Recessed Pendent Sprinklers Installation

The Series TY-L Recessed Pendent Sprinkler must be installed in accordance with the following instructions:

Step 1. After installing the Style 20 or 30 Mounting Plate, as applicable, over the sprinkler threads and with pipe thread sealant applied to the pipe threads, hand-tighten the sprinkler into the sprinkler fitting.

Step 2. Tighten the sprinkler into the sprinkler fitting using only the W-Type 10 Recessed Sprinkler Wrench (Ref. Figure 8). With reference to Figure 1, 2, or 3, apply the W-Type 10 Recessed Sprinkler Wrench to the sprinkler wrenching flanges.

Step 3. After the ceiling has been installed or the finish coat has been applied, slide on the Style 20 or 30 Closure over the Series TY-L Recessed Pendent Sprinkler and push the Closure over the Mounting Plate until its flange comes in contact with the ceiling.

Care and Maintenance

The TYCO Series TY-L 5.6 and 8.0 K-factor Upright, Pendent, and Recessed Pendent Sprinklers must be maintained and serviced in accordance with this section.

Before closing a fire protection system main control valve for maintenance work on the fire protection system that it controls, permission to shut down the affected fire protection system must be obtained from the proper authorities and all personnel who may be affected by this action must be notified.

Absence of an escutcheon, which is used to cover a clearance hole, may delay the time to sprinkler operation in a fire situation.

Sprinklers that are found to be leaking or exhibiting visible signs of corrosion must be replaced.

Automatic sprinklers must never be painted, plated, coated or otherwise altered after leaving the factory. Modified or over-heated sprinklers must be replaced. Care must be exercised to avoid damage to the sprinklers before, during, and after installation. Sprinklers damaged by dropping, striking, wrench twist/slippage, or the like, must be replaced.

Frequent visual inspections are recommended to be initially performed for corrosion resistant coated sprinklers, after the installation has been completed, to verify the integrity of the corrosion-resistant coating. Thereafter, annual inspections per NFPA 25 should suffice; however, instead of inspecting from the floor level, a random sampling of close-up visual inspections should be made so as to better determine the exact sprinkler condition and the long-term integrity of the corrosion resistant coating, as it may be affected by the corrosive conditions present.

The owner is responsible for the inspection, testing, and maintenance of their fire protection system and devices in compliance with this document, as well as with the applicable standards of the NATIONAL FIRE PROTECTION ASSOCIATION (e.g., NFPA 25), in addition to the standards of any other authorities having jurisdiction. Contact the installing contractor or product manufacturer with any questions.

It is recommended that automatic sprinkler systems be inspected, tested, and maintained by a qualified Inspection Service in accordance with local requirements and/or national codes.

P/N 53 - XXX - X - XXX

		SIN			SPRINKLER FINISH			TEMPERATURE RATING
111	5.6K UPRIGHT (1/2 in. NPT)	TY3111		1	NATURAL BRASS		165	165°F (74°C)
112	5.6K PENDENT (1/2 in. NPT)	TY3211		6	WAX COATED 165°F TO 280°F ONLY		212	212°F (100°C)
101	8.0K UPRIGHT (3/4 in. NPT)	TY4111		7	LEAD COATED		280	280°F (138°C)
102	8.0K PENDENT (3/4 in. NPT)	TY4211		8	WAX OVER LEAD 165°F TO 212°F ONLY			
106	8.0K UPRIGHT (1/2 in. NPT)	TY4811		9	CHROME PLATED			
107	8.0K PENDENT (1/2 in. NPT)	TY4911						

TABLE B
SERIES TY-L PENDENT AND UPRIGHT SPRINKLERS
PART NUMBER SELECTION

Ordering Procedure

Contact your local distributor for availability. When placing an order, indicate the full product name and Part Number (P/N).

Sprinkler Assemblies with NPT Thread Connections

Specify: Series TY-L (specify SIN), (specify K-factor), (specify Upright, Pendent, or Recessed Pendent) Sprinkler, Standard Response, Standard Coverage, (specify) temperature rating, (specify) finish or coating, P/N (specify from Table B)

Recessed Escutcheon

Specify: Style (specify) Recessed Escutcheon, (specify material) with (specify*) finish, P/N (specify*)

*Refer to Technical Data Sheet TFP770

Sprinkler Wrench

Specify: W-Type 9 Sprinkler Wrench, P/N 56-000-1-849

Specify: W-Type 10 Sprinkler Wrench, P/N 56-000-1-948

Wax Sticks (for retouching wrench-damaged wax coating)

Specify: Series TY-L Sprinklers, (specify color), color coded Wax Stick for retouching, (specify) temperature rated, P/N (specify):

Red for 165°F (74°C) P/N 56-065-1-155
Blue for 212°F (100°C)
and 280°F (138°C) P/N 56-065-1-286

Note: Each wax stick is suitable for retouching up to twenty-five sprinklers. The wax used for 280°F (138°C) sprinklers is the same as for 212°F (100°C) sprinklers. Therefore, the 280°F (138°C) sprinkler is limited to the same maximum ceiling temperature as the 212°F (100°C) sprinkler, which is 150°F (65°C).