



Resilient-Seated Gate Valves with Vertical or Cross Wall Post Indicator

General Description

TYCO Resilient-Seated Gate Valves with Vertical and Cross Wall Indicators are used in fire protection systems for on/off operation. End connection configurations including Flange by Flange, Flange by Groove, and Groove by Groove are available.

The ductile iron body weighs approximately 50% less than conventional cast iron valves, which allows easier handling on site and reduced shipping costs.

The fully encapsulated EPDM ductile iron wedge ensures drop-tight sealing.

Valve components are either inherently corrosion-resistant or protected with fusion-bonded epoxy resin coating for a long, reliable service life and enhanced UV protection in exposed installations.

This valve is one of the lightest, most durable gate valves on the market today. Its design features and material selection criteria fulfill the need for a reliable, long life and easy to operate gate valve.

These valves are available with either Vertical Indicators for underground water supplies or Cross Wall Indicators for interior water systems. Both indicators provide external visual indication of the open or shut valve condition as well as a locking mechanism to secure a particular wedge position.

NOTICE

Never remove any piping component nor correct or modify any piping deficiencies without first de-pressurizing and draining the system. Failure to do so may result in serious personal injury, property damage, and/or impaired device performance.

It is the designer's responsibility to select products suitable for the

IMPORTANT

Refer to Technical Data Sheet TFP2300 for warnings pertaining to regulatory and health information.

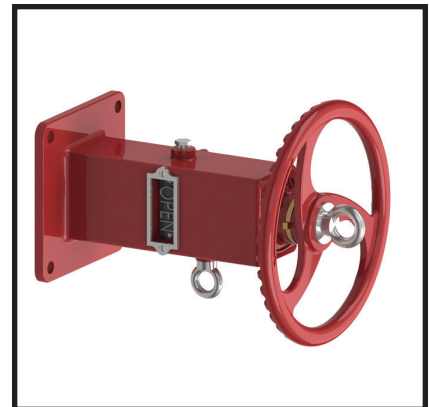

intended service and to ensure that pressure ratings and performance data are not exceeded. Material and gasket selection should be verified for compatibility with the specific application. Always read and understand the installation instructions.

TYCO Gate Valves described herein must be installed and maintained in compliance with this document, in addition to the standards of any other authorities having jurisdiction. Failure to do so may result in serious personal injury or impair the performance of these devices.

The owner is responsible for maintaining their mechanical system and devices in proper operating condition. The installing contractor or device manufacturer should be contacted with any questions.

Technical Data

Sizes

4" (DN100), 6" (DN150), 8" (DN200),
10" (DN250), and 12" (DN300)

Approvals

FM Approved
UL Listed

Maximum Working Pressure

FM - 232 psi (16 bar)
UL - 300 psi (20,7 bar)

Flanges

ASME B16.1/ASME B16.42
EN 1092-2/ISO 7005-2/

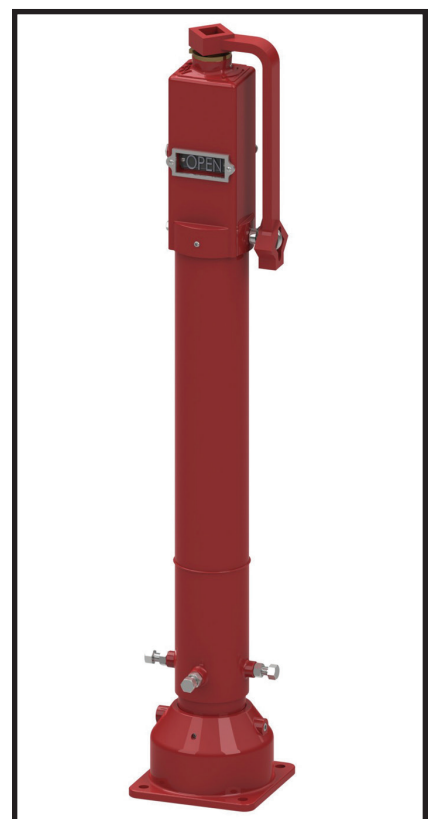

Drilled to ANSI 125/150, PN10/PN16, or AS 2129 (Table E)

Materials of Construction

See individual valve and indicator parts lists, Figures 1, 4, and 6.

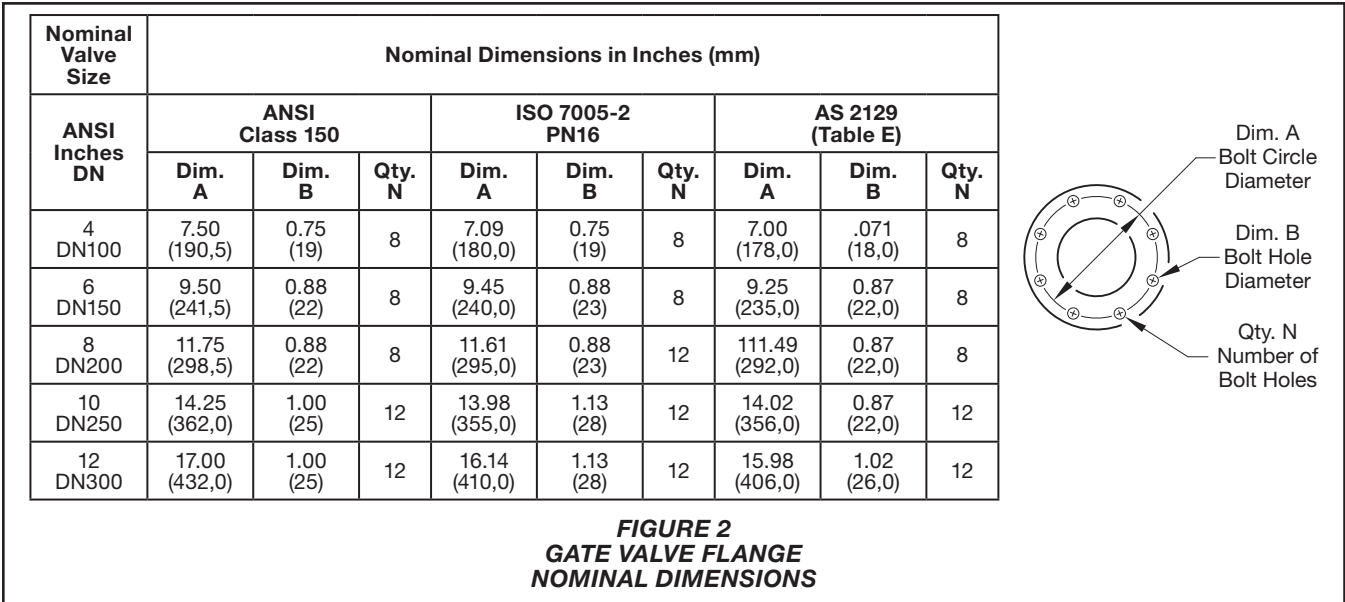
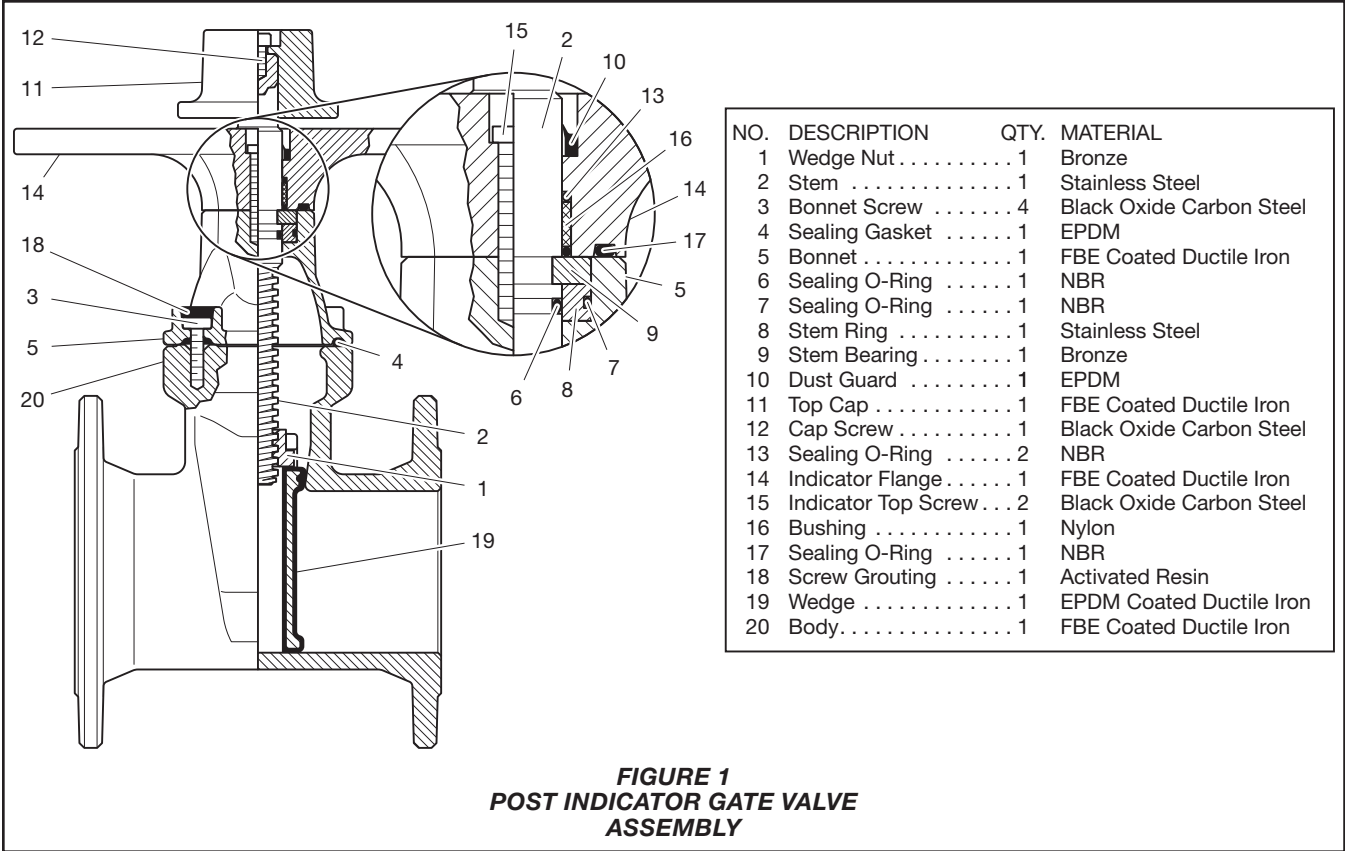

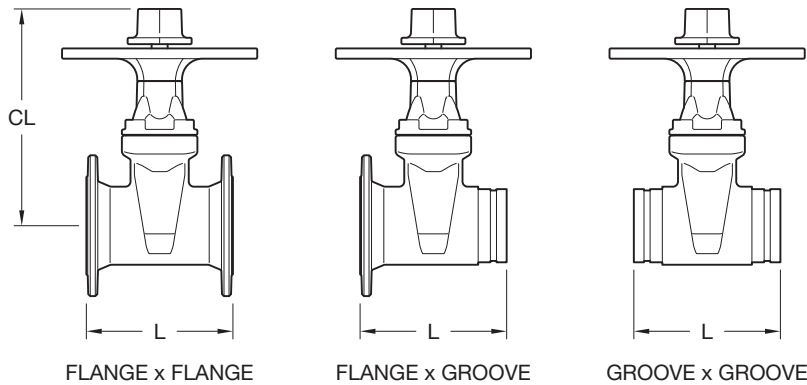

Nominal Valve Size	Nominal Pipe Size	Nominal Dimensions Inches (mm)		Approx. Weight F x F Lbs. (kg)	Approx. Weight F x G Lbs. (kg)	Approx. Weight G x G Lbs. (kg)
		L	CL			
4 DN100	4.500 (114,3)	9.00 (229)	13.07 (332)	70.5 (32)	55.1 (25)	48.5 (22)
— DN150	6.500 (165,1)	10.50 (267)	17.17 (436)	—	83.8 (38)	75.0 (34)
6 DN150	6.625 (168,3)	10.50 (267)	17.17 (436)	103.6 (47)	83.8 (38)	75.0 (34)
8 DN200	8.625 (219,1)	11.50 (292)	20.47 (520)	169.7 (77)	134.5 (61)	123.5 (56)
10 DN250	10.750 (273,1)	13.00 (330)	24.41 (620)	240.3 (109)	202.8 (92)	180.8 (82)
12 DN300	12.750 (323,9)	14.00 (356)	26.38 (670)	295.4 (134)	262.4 (119)	235.9 (107)

FIGURE 3
POST INDICATOR GATE VALVE
NOMINAL DIMENSIONS

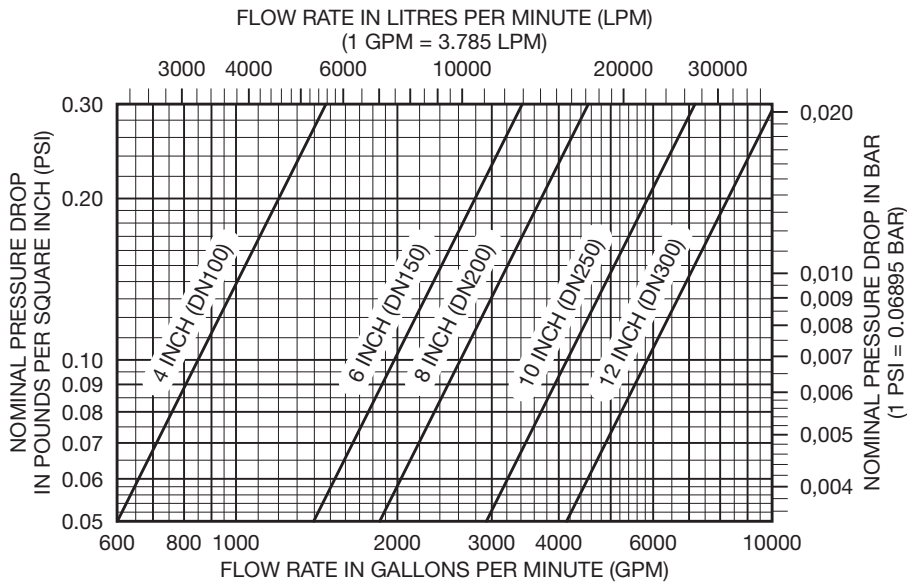

GRAPH A
GATE VALVE FRICTION LOSS

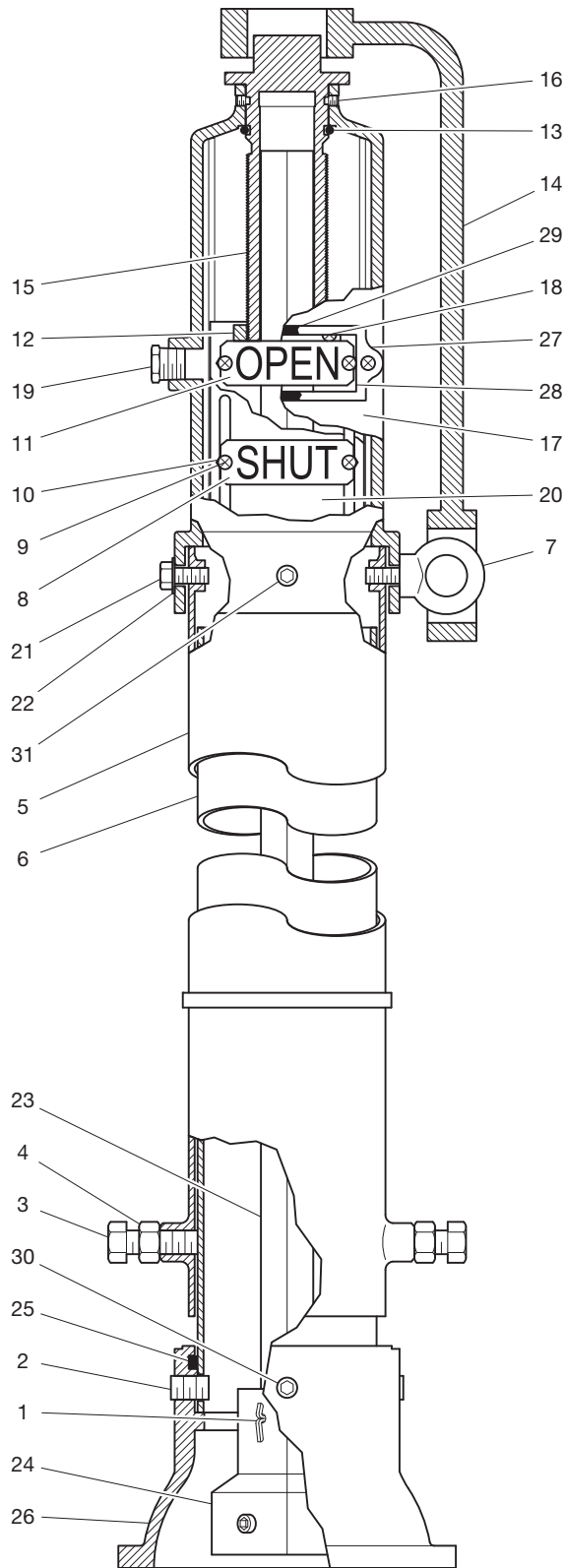

NO.	DESCRIPTION	QTY.	MATERIAL
1	Cotter Pin	1	Carbon Steel
2	Screw Pin	2	Zinc Coated Carbon Steel
3	Hex Cap Screw M16	4	Zinc Coated Carbon Steel
4	Hex Nut M16	4	Zinc Coated Carbon Steel
5	Upper Pipe	1	FBE Coated Carbon Steel
6	Lower Pipe	1	FBE Coated Carbon Steel
7	Eye Bolt M12	1	Zinc Coated Carbon Steel
8	Target "SHUT"	1	Aluminum
9	Screw M6	12	Zinc Coated Carbon Steel
10	Hex Nut M6	8	Zinc Coated Carbon Steel
11	Target "OPEN"	1	Aluminum
12	Stem Nut	1	Bronze
13	O-Ring	1	NBR
14	Wrench	1	FBE Coated Ductile Iron
15	Operating Stem	1	Bronze
16	Hex Socket Set Screw	2	Stainless Steel
17	Post Cap	1	FBE Coated Ductile Iron
18	Screw M6	4	Zinc Coated Carbon Steel
19	Pipe Plug 1/2" NPT.	1	Zinc Coated Carbon Steel
20	Carrier Plate	2	Carbon Steel
21	Hex Cap Screw M12	1	Zinc Coated Carbon Steel
22	Flat Washer M12	1	Zinc Coated Carbon Steel
23	Extension Rod	1	FBE Coated Carbon Steel
24	Connect Cap	1	FBE Coated Ductile Iron
25	O-Ring	1	NBR
26	Bottom Flange	1	FBE Coated Ductile Iron
27	Ferrule	2	Carbon Steel
28	Window	2	Plastic
29	Gasket	2	NBR
30	Hex Socket Set Screw	2	Stainless Steel
31	Hex Socket Set Screw	2	Stainless Steel

FIGURE 4
VERTICAL INDICATOR POST
ASSEMBLY

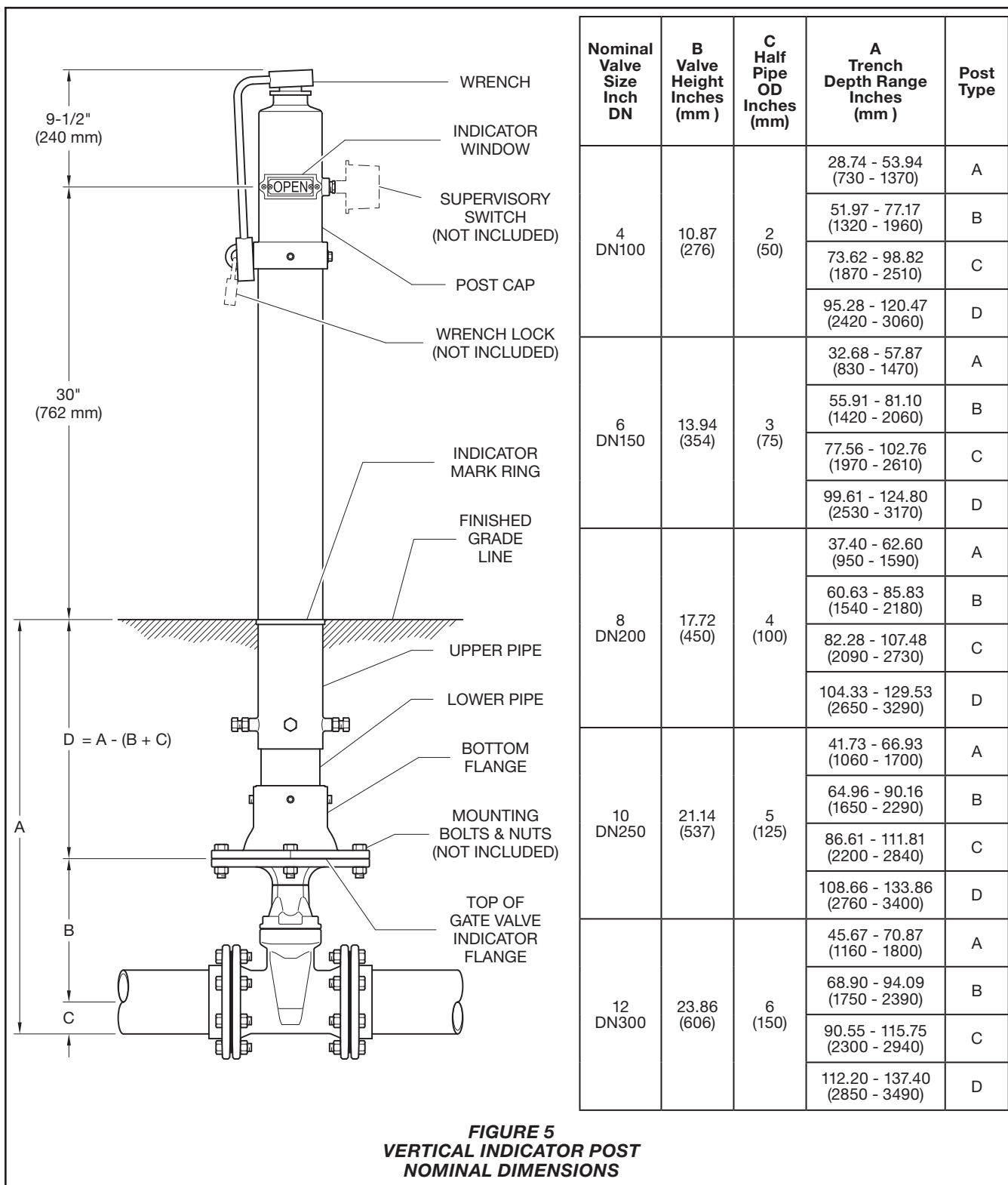

Installation Gate Valve and General Instructions

In piping systems, TYCO Resilient-Seated Gate Valves with Vertical and Cross Wall Indicators should be located where operation, inspection, and maintenance are readily accessible.

Installation instructions for the Vertical Indicator Post are located on page 6.

Installation instructions for the Cross Wall Indicator Post are located on page 10.

Installation Vertical Indicator Post

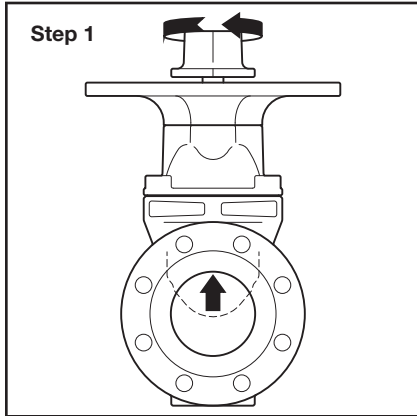

Step 1. Rotate Gate Valve Top Cap clockwise to fully open Gate Valve.

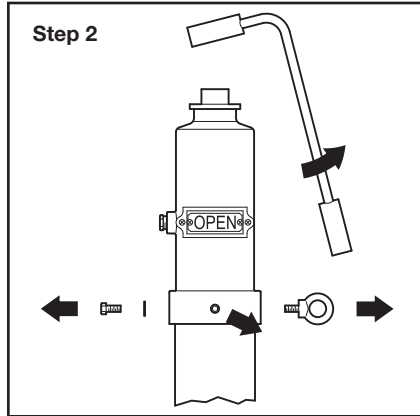

Step 2. Remove Wrench from Post Assembly. Loosen Set Screws. Remove Screw, Washer, and Eyebolt.

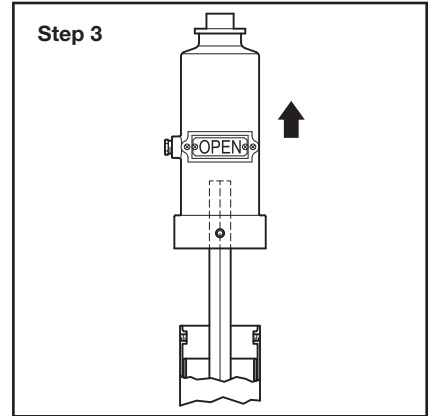

Step 3. Remove Cap Assembly from Post Assembly.

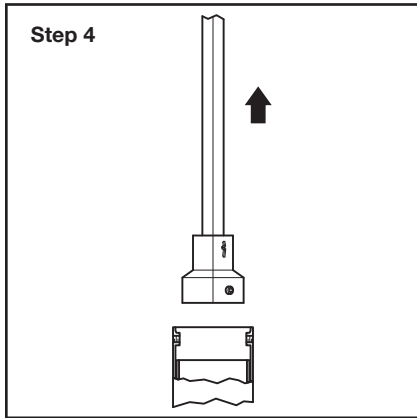

Step 4. Remove Extension Rod from Post Assembly.

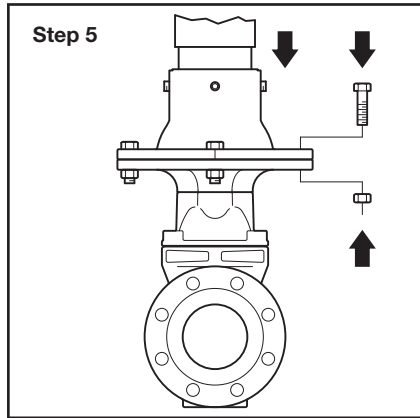

Step 5. Temporarily mount Post Assembly to Gate Valve Indicator Flange and secure with four bolts and nuts (not included).

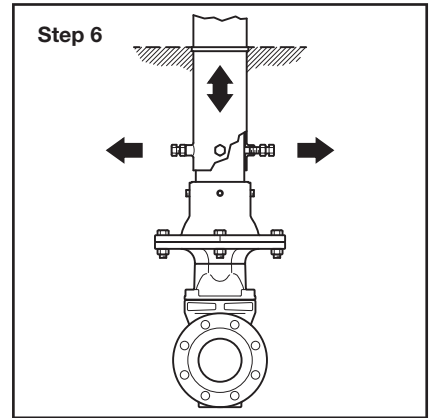

Step 6. Loosen Screws and Lock Nuts securing Upper Pipe to Lower Pipe. Adjust Upper Pipe, aligning Mark Ring height with finished grade.

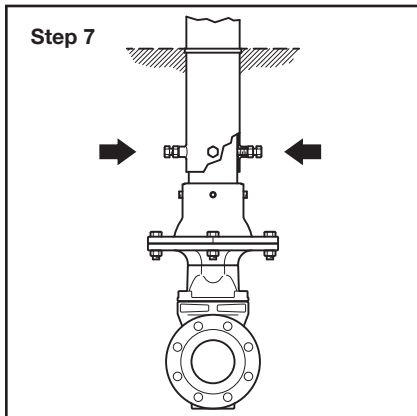

Step 7. Tighten Screws and Lock Nuts to secure Upper Pipe to Lower Pipe.

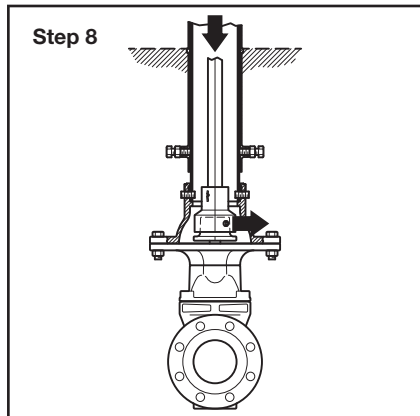

Step 8. Loosen Connect Cap Set Screws. Temporarily Install Extension Rod Assembly in Post Assembly, engaging Gate Valve Top Cap by Connect Cap.

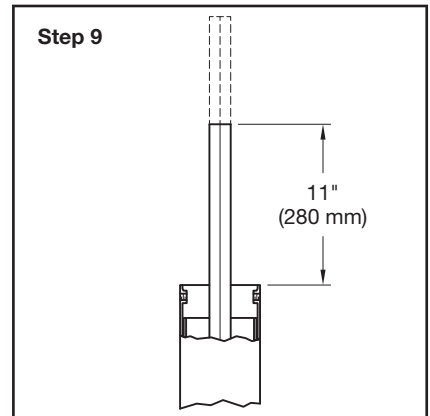

Step 9. Mark Extension Rod 11 inches (280 mm) above top of Upper Pipe. Remove Extension Rod Assembly. Evenly cut Extension Rod at marked location.

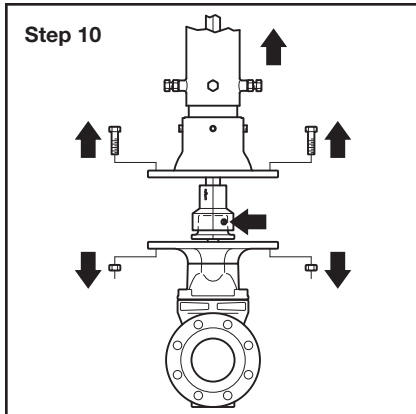

Step 10. Remove Post Assembly and install Extension Rod Assembly, engaging Gate Valve Top Cap by Connect Cap. Tighten Connect Cap Set Screws to secure.

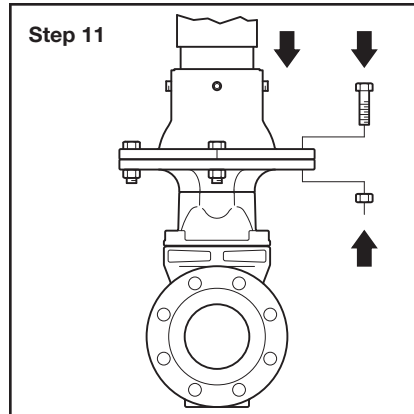

Step 11. Mount Post Assembly to Gate Valve Indicator Flange and secure with four bolts and nuts.

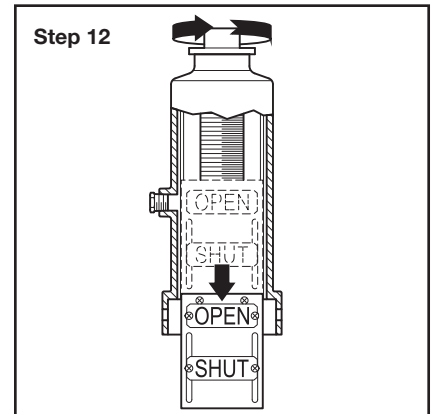

Step 12. Rotate Operating Stem counterclockwise to remove Target Carrier from Cap.

Step 13

Nominal Valve Size		Dimension P	
Inches	DN	Inches	mm
4	100	1.50	38
6	150	2.28	58
8	200	2.88	73
10	250	3.38	86
12	300	4.00	101

Step 13. Loosen SHUT Target Screws and Nuts and adjust position per table above. Tighten Screws and Nuts. Repeat for opposite side of Target Carrier assembly.

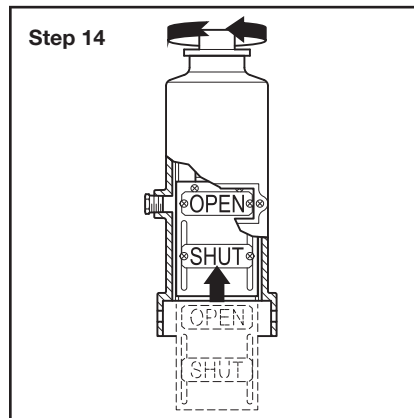

Step 14. Position Target Carrier in Cap cavity and engage Operating Stem by Stem Nut. Rotate Operating Stem clockwise until OPEN Targets are centered in Cap windows.

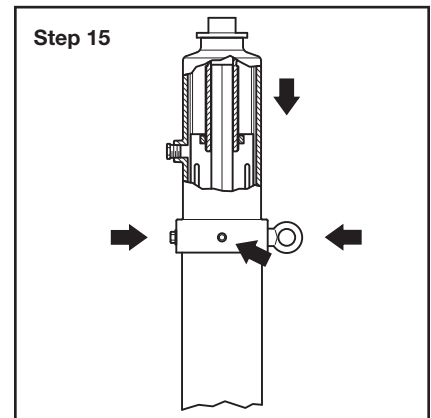

Step 15. Engage Extension Rod by Operating Stem and install Cap Assembly on Post Assembly. Install and tighten Screw, Washer, and Eyebolt. Tighten Set Screws to secure.

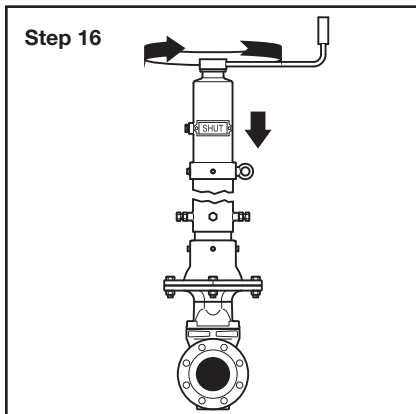

Step 16. Engage Operating Stem with Wrench. Rotate Wrench counterclockwise until SHUT Targets are centered in Cap windows. Ensure that Gate Valve is fully shut.

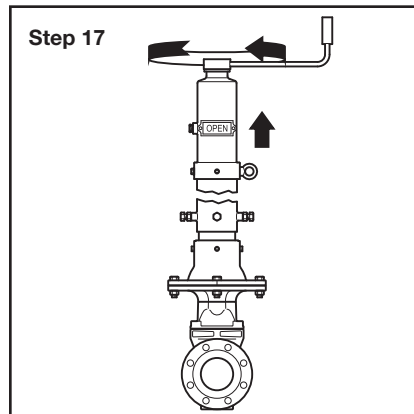

Step 17. Engage Operating Stem with Wrench. Rotate Wrench clockwise until OPEN Targets are centered in Cap windows. Ensure that Gate Valve is fully open.

NO.	DESCRIPTION	QTY.	MATERIAL
1	Connect Cap	1	FBE Coated Ductile Iron
2	Cotter Pin	1	Carbon Steel
3	Post Body	1	FBE Coated Ductile Iron
4	Carrier Plate	2	Carbon Steel
5	Hex Nut M6	8	Zinc Coated Carbon Steel
6	Pipe Plug 1/2" NPT	1	Zinc Coated Carbon Steel
7	Screw M6	4	Zinc Coated Carbon Steel
8	Stem Nut	1	Bronze
9	Operating Stem	1	Bronze
10	Handwheel	1	FBE Coated Ductile Iron
11	Eye Bolt M16	1	Zinc Coated Carbon Steel

NO.	DESCRIPTION	QTY.	MATERIAL
12	Flat Washer M16	1	Zinc Coated Carbon Steel
13	Hex Socket Set Screw	2	Stainless Steel
14	O-Ring	1	NBR
15	Eye Bolt M12	1	Zinc Coated Carbon Steel
16	Screw M6	12	Zinc Coated Carbon Steel
17	Ferrule	2	Carbon Steel
18	Window	2	Plastic
19	Gasket	2	NBR
20	Target "OPEN"	1	Aluminum
21	Target "SHUT"	1	Aluminum
22	Extension Rod	1	FBE Coated Carbon Steel

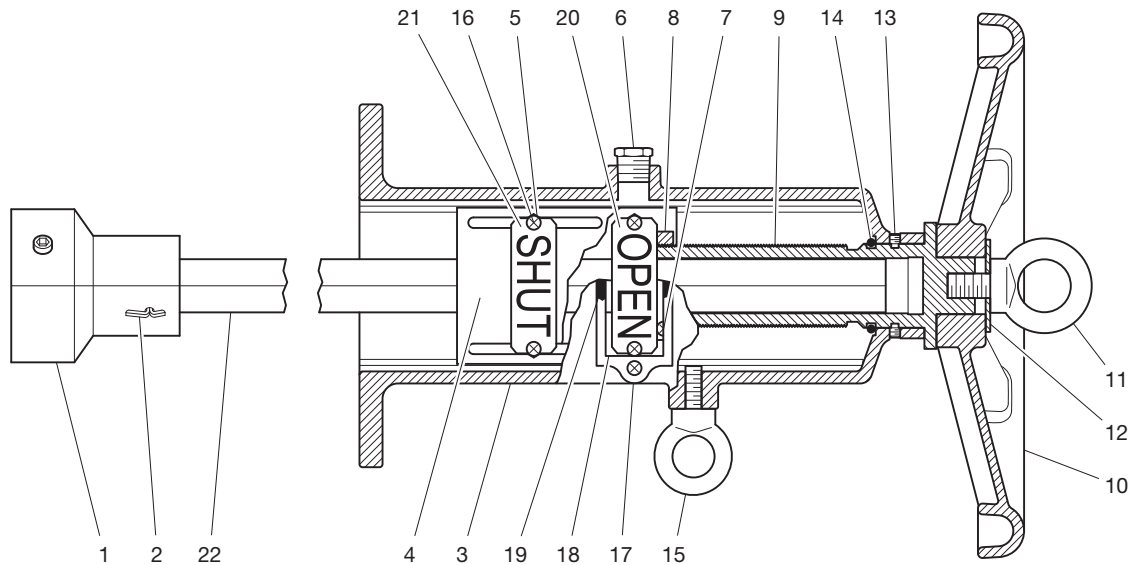
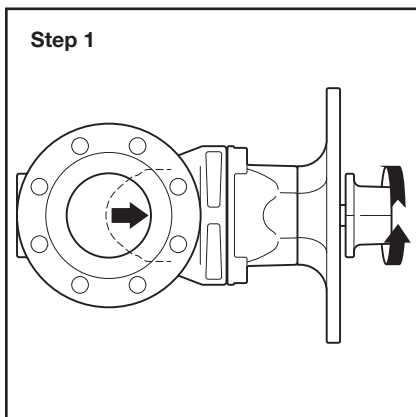
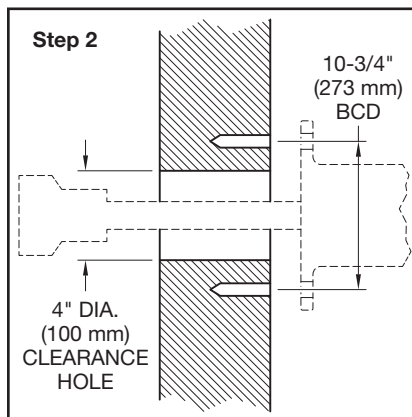

FIGURE 6
CROSS WALL INDICATOR POST
ASSEMBLY

Installation Cross Wall Indicator Post



Step 1. Rotate Gate Valve Top Cap clockwise to fully open Gate Valve.



Step 2. Cut hole in wall for Connect Cap clearance. Drill four anchor bolt holes on 10-3/4 inch (273 mm) BCD for securing Post Body to wall in orientation shown in Step 10.

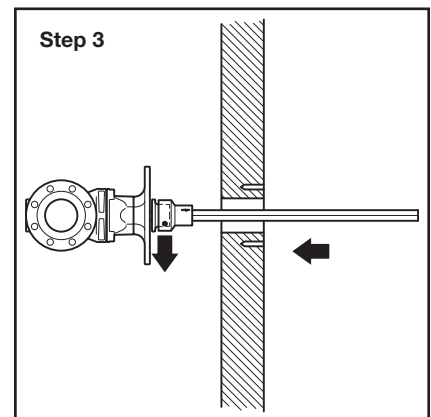

Step 3. Loosen Connect Cap Set Screws. Insert Extension Rod Assembly through wall clearance hole and temporarily engage Gate Valve Top Cap by Connect Cap.

Nominal Valve Size Inch DN	A Connect Cap Engagement Height Inches (mm)	B Valve Height Inches (mm)
4 DN100	11.77 (299)	10.87 (276)
6 DN150	15.87 (403)	13.94 (354)
8 DN200	19.17 (487)	17.72 (450)
10 DN250	23.11 (587)	21.14 (537)
12 DN300	25.08 (637)	23.86 (606)

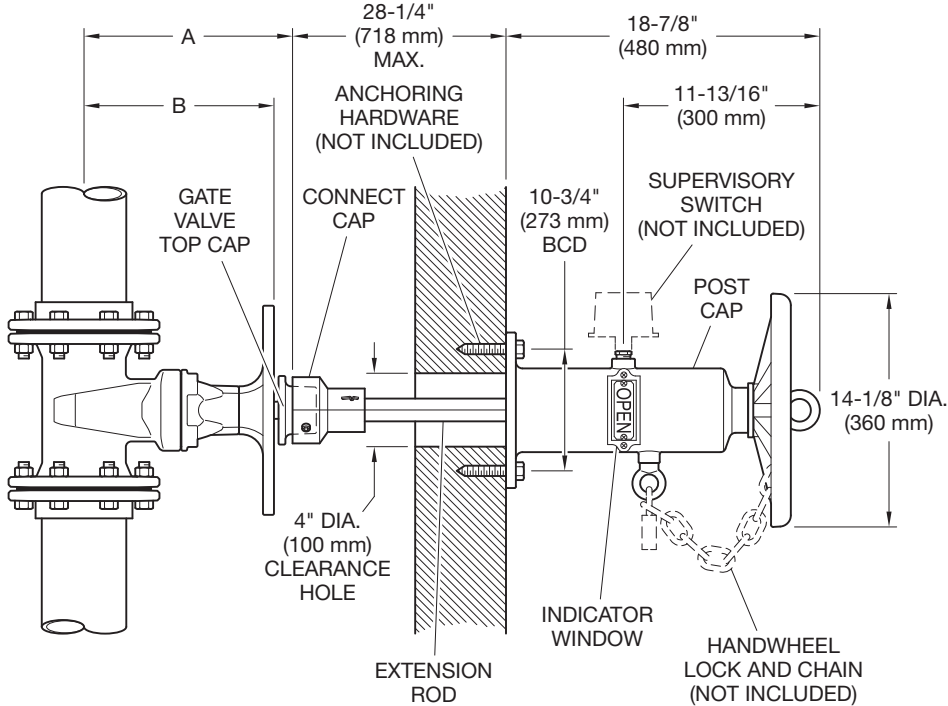
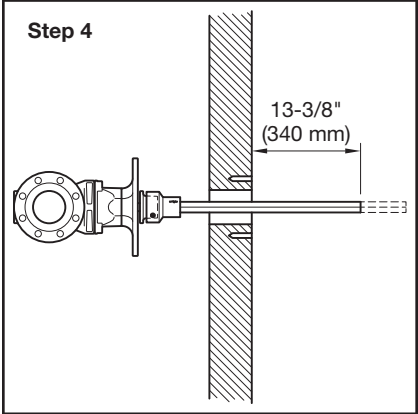
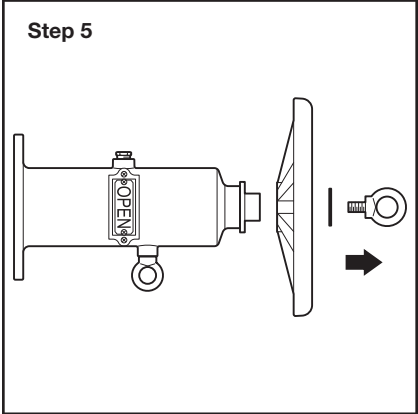

FIGURE 7
CROSS WALL INDICATOR POST
NOMINAL DIMENSIONS



Step 4. Mark Extension Rod 13-3/8 inches (340 mm) from wall. Remove Extension Rod Assembly and evenly cut extension Rod at marked location.



Step 5. Remove Eyebolt, Washer and Handwheel from Cap Assembly.

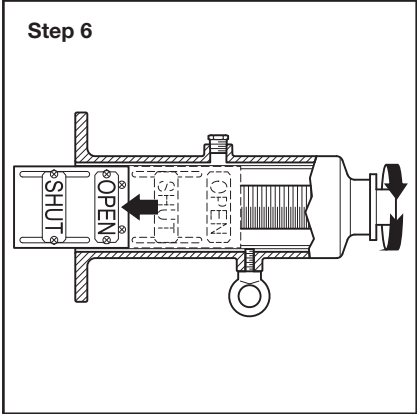

Step 6. Rotate Operating Stem counterclockwise to remove Target Carrier from Cap.

Installation Cross Wall Indicator Post

Step 7

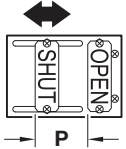

Nominal Valve Size		Dimension P	
Inches	DN	Inches	mm
4	100	1.50	38
6	150	2.28	58
8	200	2.88	73
10	250	3.38	86
12	300	4.00	101

Step 7. Loosen SHUT Target Screws and Nuts and adjust position per table above. Tighten Screws and Nuts. Repeat for opposite side of Target Carrier assembly.

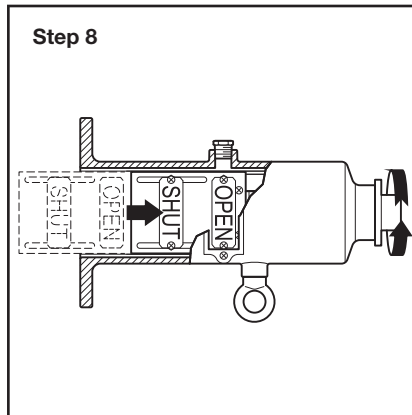

Step 8. Position Target Carrier in Cap cavity and engage Operating Stem by Stem Nut. Rotate Operating Stem clockwise until OPEN Targets are centered in Cap windows.

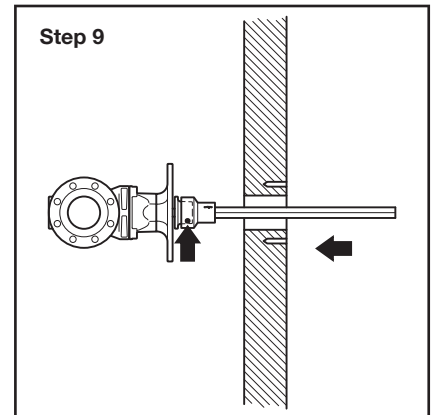

Step 9. Install Extension Rod Assembly engaging Gate Valve Top Cap by Connect Cap. Tighten Connect Cap Set Screws to secure.

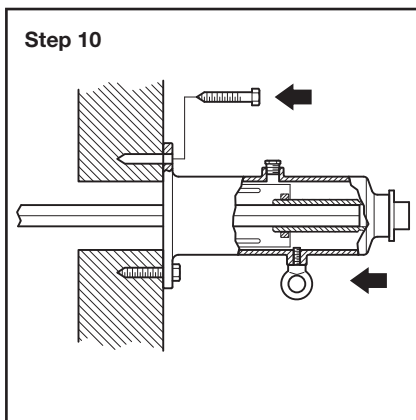

Step 10. Engage Extension Rod Assembly by Operating Stem and guide Cap Assembly into position over anchor bolt holes. Hold in place and secure with four anchor bolts (not included).

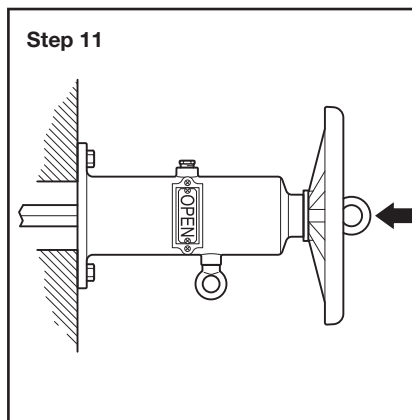

Step 11. Attach Handwheel to Cap Assembly and secure with Eyebolt and Washer.

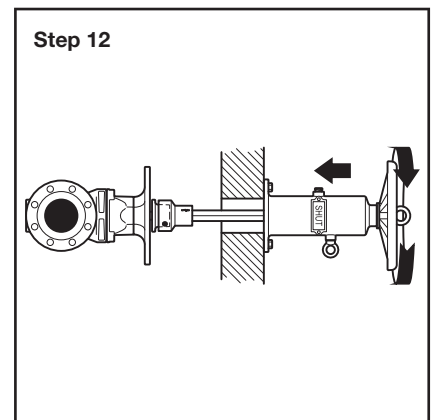

Step 12. Rotate Handwheel counter-clockwise until SHUT Targets are centered in Cap windows. Ensure that Gate Valve is fully shut.

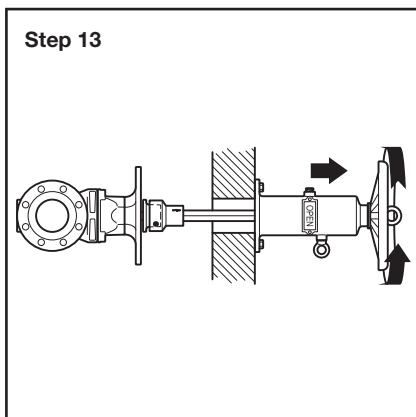

Step 13. Rotate Handwheel clockwise until OPEN Targets are centered in Cap windows. Ensure that Gate Valve is fully open.

Care and Maintenance

The TYCO Resilient-Seated Gate Valves with Vertical or Cross Wall Post Indicators must be maintained and serviced in accordance with this section.

Before closing a fire protection system main control valve for maintenance work on the fire protection system that it controls, permission to shut down the affected fire protection system must be obtained for the proper authorities and notify all personnel who may be affected by this action.

After placing a fire protection system in service, notify the proper authorities

and advise those responsible for monitoring proprietary and/or central station alarms.

The owner is responsible for the inspection, testing, and maintenance of their fire protection system and devices in compliance with this document, as well as with the applicable standards of the National Fire Protection Association (e.g., NFPA 25), in addition to the standards of any authorities having jurisdiction. Contact the installing contractor or sprinkler manufacturer regarding any questions.

Automatic sprinkler systems are recommended to be inspected, tested, and maintained by a qualified inspection service in accordance with local requirements and/or national codes.

Nominal Valve Size	Nominal Pipe Size	Part Number					
		Flange x Flange ANSI Class 150	Flange x Flange ISO 7005-2 PN16	Flange x Groove ANSI Class 150	Flange x Groove ISO 7005-2 PN16	Flange x Flange AS 2129 (Table E)	Groove x Groove
4 DN100	4.500 (114,3)	TMPX-1000003	TMPX-1000001	TMPT-1001143	TMPT-1001141	TMPX-1000005	TMPG-1001144
– DN150	6.500 (165,1)	–	–	TMPT-1501653	TMPT-1501651	–	TMPG-1501654
6 DN150	6.625 (168,3)	TMPX-1500003	TMPX-1500001	TMPT-1501683	TMPT-1501681	TMPX-1500005	TMPG-1501684
8 DN200	8.625 (219,1)	TMPX-2000003	TMPX-2000001	TMPT-2002193	TMPT-2002191	TMPX-2000005	TMPG-2002194
10 DN250	10.750 (273,1)	TMPX-2500003	TMPX-2500001	TMPT-2502733	TMPT-2502731	TMPX-2500005	TMPG-2502734
12 DN300	12.750 (323,9)	TMPX-3000003	TMPX-3000001	TMPT-3003243	TMPT-3003241	TMPX-3000005	TMPG-3003244

**TABLE A
POST INDICATOR GATE VALVE
PART NUMBERS**

Indicator Post	Size Inches (mm)	Part Number
Vertical Type A	15.9–41.1 (403–1043)	TMUP-A
Vertical Type B	39.2–64.4 (995–1635)	TMUP-B
Vertical Type C	60.8–86.0 (1545–2185)	TMUP-C
Vertical Type D	82.7–107.9 (2100–2740)	TMUP-D
Cross Wall	-	TMWP

**TABLE B
VERTICAL AND CROSS WALL
INDICATOR POST
PART NUMBERS**

Gate Valve

Debris lodged in the sealing area of the wedge may cause the valve to close hard. Backing off the indicator wrench or handwheel and closing it again, several times if necessary, can correct this problem.

The valve should never be forced to seat by applying a wrench or extension to the lever, as it may distort the valve components or score the sealing surfaces. All replacement parts must be obtained from the manufacturer to assure proper operation of the valve.

Vertical Indicator Post

It is recommended that Vertical Indicator Posts used to operate fire protection system water control valves be locked in the fully open position using the wrench. The locks must be sturdy

and resistant to breakage except by heavy bolt cutters.

It is recommended that a visual inspection be carried out on a monthly basis to ensure:

- the Post Cap, Upper Barrel, and windows have not been damaged
- the Targets indicate that the valve is open
- the Wrench is in place on the Post and is securely locked

It is further recommended that on a quarterly basis, the Vertical Indicator Post should be closed two turns and then reopened to verify that the PIV is in the fully open position and properly engages with the Post. Where a Supervisory Switch is installed, a check should be undertaken to ensure that the contacts are working properly.

Any missing or damaged parts should be immediately replaced.

Cross Wall Indicator Post

It is recommended that Cross Wall Indicator Posts used to operate fire protection system water control valves be locked in the fully open position using the Handwheel. The locks must be sturdy and resistant to breakage except by heavy bolt cutters.

It is recommended that a visual inspection be carried out on a monthly basis to ensure:

- the Post body, Handwheel, and windows have not been damaged
- the Targets indicate that the valve is open
- the Post is properly locked open

It is further recommended that on a quarterly basis, the Cross Wall Indi-

cator Post should be closed two turns and then reopened to verify that the PIV is in the fully open position and properly engages with the Post and that the Supervisory Switch contacts are working properly.

Any damaged parts should be immediately replaced.

Ordering Procedure

Contact your local distributor for availability. When placing an order, indicate the full product name and Part Number (P/N).

Refer to Table A for Gate Valve part numbers and Table B for Vertical and Cross Wall Indicator Post part numbers.

Replacement Indicator Window

Specify: Indicator Window, P/N 11047895

Replacement Vertical Indicator Post Wrench

All Vertical Indicator Post types feature a removable wrench for operating the PIV. Replace as necessary.

Specify: Vertical Indicator Post Wrench, P/N WRENCH-TMUP

