

## Preaction System with DV-5 Deluge Valve Double Interlock – Electric/Electric Actuation

### General Description

The TYCO DV-5 Double Interlock Preaction System with Electric/Electric Actuation (Fig. 1) is designed for use in applications, such as refrigerated areas, requiring the maximum degree of protection against inadvertent flooding of the sprinkler system piping.

The DV-5 Double Interlock Preaction System with Electric/Electric Actuation utilizes a DV-5 Deluge Valve and a Riser Check Valve. The Riser Check Valve (that does not require the use of priming water) isolates the Deluge Valve from the system air pressure. The releasing trim for the Deluge Valve utilizes a Solenoid Valve that is operated by energizing the releasing circuit of a Cross-Zone Deluge Valve Releasing Panel (automatic control unit).

Zone 1 of the Releasing Panel is operated by either a fire detection device or manual pull station. Zone 2 of the Releasing Panel is operated by a Low Air Pressure Alarm Switch in response to a loss of system air pressure due to the opening of an automatic sprinkler. The Solenoid Valve remains closed until it is electrically energized by the Releasing Panel.

In order for the Double Interlock Preaction System to automatically actuate, two independent events must occur. Zone 1 of the Releasing Panel must operate upon automatic operation of the electric fire detection initiating circuit or operation of the electric-manual pull initiating circuit, and Zone 2 of the Releasing Panel must operate via the Low Air Pressure Alarm Switch upon loss of air pressure from the sprinkler system piping, due to operation of one or more sprinklers.

The Double Interlock Preaction System will automatically actuate only when both Zone 1 and Zone 2 of the Releasing Panel have operated, energizing the Solenoid Valve. Accidental loss of system air pressure (e.g.: a lift truck accidentally dislodges a sprinkler), or operation of just the fire detection circuit (e.g.: an accidental operation of

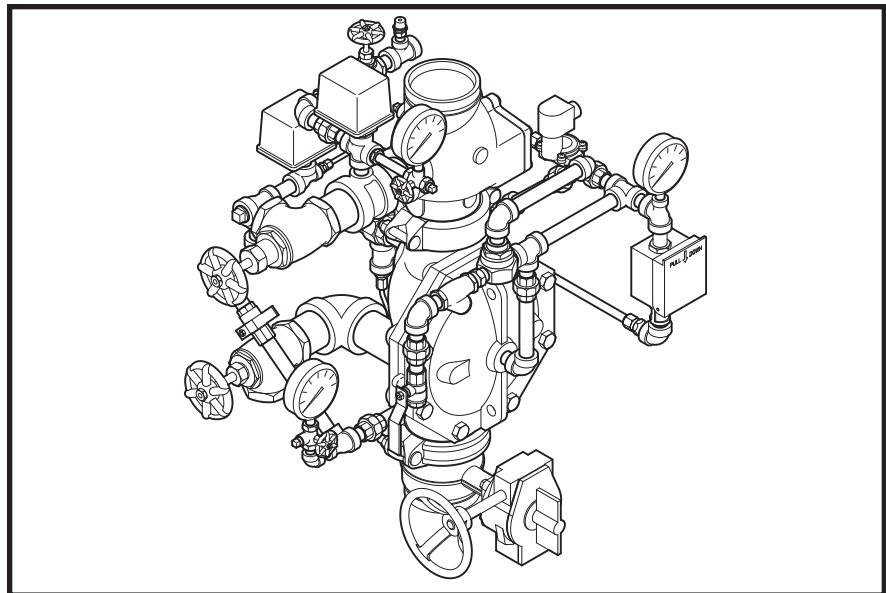

an electric pull station), will only cause an alarm, and will not actuate the system or flood the sprinkler system piping.

The DV-5 Deluge Valve (described in Technical Data Sheet TFP1305) is a diaphragm style valve that depends upon water pressure in the Diaphragm Chamber to hold the Diaphragm closed against the water supply pressure. When the DV-5 Valve is set for service, the Diaphragm Chamber is pressurized through the trim connections from the inlet side of the system's main control valve, for example an O.S.&Y. gate valve or butterfly valve (Fig. 1).

Operation the Solenoid Valve releases water from the Diaphragm Chamber faster than it can be replenished through the 1/8 inch (3,2 mm) restriction provided by the Model ASV-1 Automatic Shut-Off Valve in the diaphragm supply connections (Item 5 - Fig. 3A, also described in Technical Data Sheet TFP1384). This results in a rapid pressure drop in the Diaphragm Chamber below the valve trip point. The water supply pressure then forces the Diaphragm open permitting water to flow into the system piping, as well as through the Alarm Port to actuate the system alarms.

As water flows into the system, the pilot chamber of the Model ASV-1 Automatic Shut-Off Valve (Item 5 -Fig. 3A) becomes pressurized and the ASV-1 automatically shuts off the diaphragm chamber supply flow to the DV-5 Diaphragm Chamber. Shutting off the diaphragm chamber supply flow prevents the DV-5 Diaphragm Chamber from becoming re-pressurized, thereby preventing inadvertent closing of the DV-5 during a fire (as may be the case should the Solenoid Valve become de-energized after its initial operation).

#### **NOTICE**

*The DV-5 Double Interlock Preaction System with Electric/Electric Actuation described herein must be installed and maintained in compliance with this document, as well as with the applicable standards of the National Fire Protection Association, in addition to the standards of any other authorities having jurisdiction. Failure to do so may impair the performance of the related devices.*

*The owner is responsible for maintaining their fire protection system and devices in proper operating condition. Contact the installing contractor or product manufacturer with any questions.*

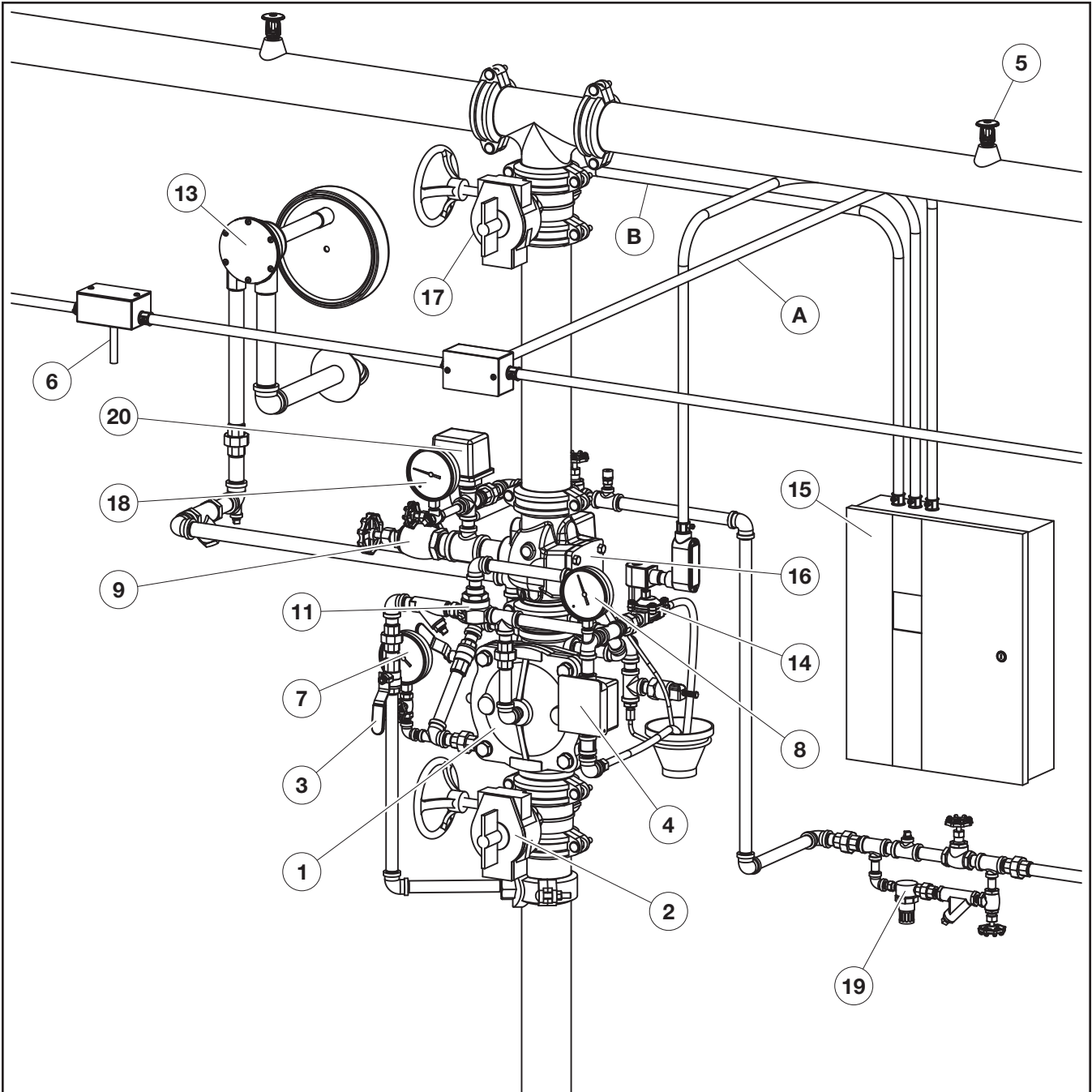

- |  |  |  |
|--|--|--|
| 1 - DV-5 Deluge Valve                                      | 9 - System Drain Valve (N.C.)                                    | 16 - Riser Check Valve                             |
| 2 - Main Control Valve (N.O.)                              | 10 - Main Drain Valve (N.C.)<br>(Shown at Rear of Valve)         | 17 - System Shut-Off Valve (N.O.)                  |
| 3 - Diaphragm Chamber Supply Control Valve (N.O.)          | 11 - Diaphragm Chamber Automatic Shut-Off Valve                  | 18 - Air Pressure Gauge                            |
| 4 - Local Manual Control Station                           | 12 - Waterflow Pressure Alarm Switch<br>(Shown at Rear of Valve) | 19 - Automatic Air/Nitrogen Supply                 |
| 5 - Automatic Sprinklers                                   | 13 - Water Motor Alarm (Optional)                                | 20 - Low Pressure Alarm Switch                     |
| 6 - Heat Detectors, Smoke Detectors, etc. (Fire Detection) | 14 - Solenoid Valve  | A - Fire Detection Initiating Circuit (Zone 1)     |
| 7 - Water Supply Pressure Gauge                            | 15 - Cross-Zone Deluge Valve Releasing Panel                     | B - Low Pressure Alarm Initiating Circuit (Zone 2) |
| 8 - Diaphragm Chamber Pressure Gauge                       |  |  |

**FIGURE 1 (1 OF 2)**  
**DOUBLE INTERLOCK PREACTION SYSTEM WITH ELECTRIC/ELECTRIC ACTUATION**  
**WITHOUT MODEL QRS ELECTRONIC ACCELERATOR**  
**SYSTEM SCHEMATIC (FRONT VIEW)**

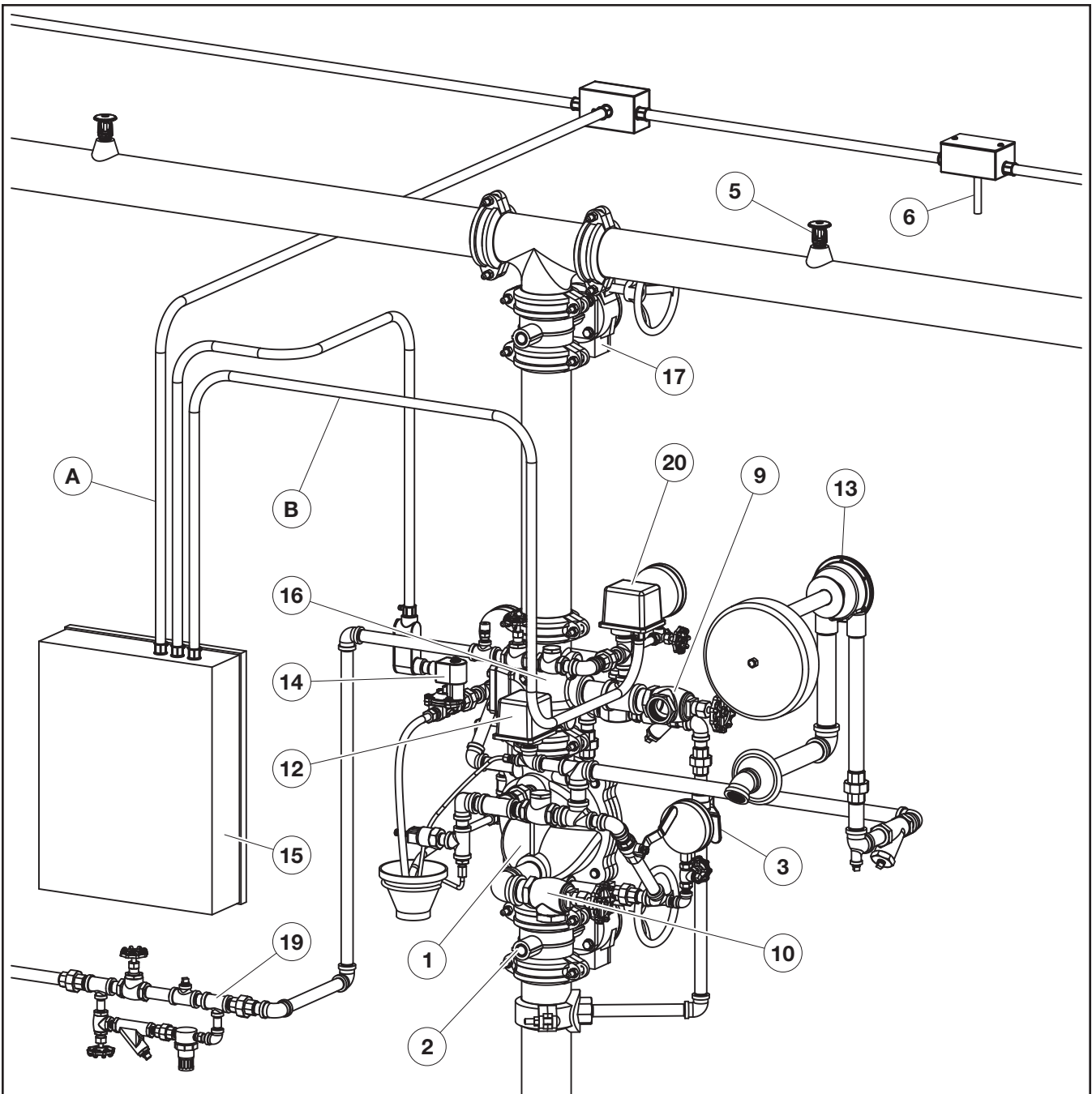

- |  |  |  |
|--|--|--|
| 1 - DV-5 Deluge Valve                                      | 8 - Diaphragm Chamber Pressure Gauge (Shown at Front of Valve) | 16 - Riser Check Valve                             |
| 2 - Main Control Valve (N.O.)                              | 9 - System Drain Valve (N.C.)                                  | 17 - System Shut-Off Valve (N.O.)                  |
| 3 - Diaphragm Chamber Supply Control Valve (N.O.)          | 10 - Main Drain Valve (N.C.)                                   | 18 - Air Pressure Gauge (Shown at Front of Valve)  |
| 4 - Local Manual Control Station (Shown at Front of Valve) | 11 - Diaphragm Chamber Automatic Shut-Off Valve                | 19 - Automatic Air/Nitrogen Supply                 |
| 5 - Automatic Sprinklers                                   | 12 - Waterflow Pressure Alarm Switch                           | 20 - Low Pressure Alarm Switch                     |
| 6 - Heat Detectors, Smoke Detectors, etc. (Fire Detection) | 13 - Water Motor Alarm (Optional)                              | A - Fire Detection Initiating Circuit (Zone 1)     |
| 7 - Water Supply Pressure Gauge (Shown at Front of Valve)  | 14 - Solenoid Valve  | B - Low Pressure Alarm Initiating Circuit (Zone 2) |
|  | 15 - Cross-Zone Deluge Valve Releasing Panel                   |  |

**FIGURE 1 (2 OF 2)**  
**DOUBLE INTERLOCK PREACTION SYSTEM WITH ELECTRIC/ELECTRIC ACTUATION**  
**WITHOUT MODEL QRS ELECTRONIC ACCELERATOR**  
**SYSTEM SCHEMATIC (REAR VIEW)**

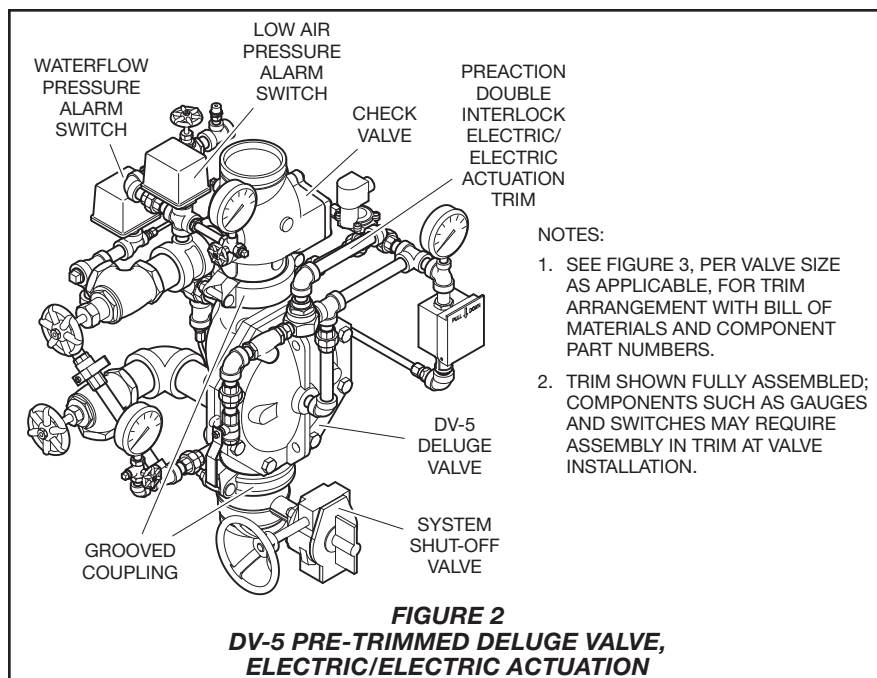

- NOTES:
1. SEE FIGURE 3, PER VALVE SIZE AS APPLICABLE, FOR TRIM ARRANGEMENT WITH BILL OF MATERIALS AND COMPONENT PART NUMBERS.
  2. TRIM SHOWN FULLY ASSEMBLED; COMPONENTS SUCH AS GAUGES AND SWITCHES MAY REQUIRE ASSEMBLY IN TRIM AT VALVE INSTALLATION.

## Technical Data

**Approvals**  
UL and C-UL Listed  
FM Approved

**Deluge Valve**  
DV-5

**Riser Check Valve**  
Model CV-1FR

**NOTE:** 1-1/2 inch (DN40) risers utilize a 2 inch (DN50) Model CV-1FR Riser Check Valve connected to the 1-1/2 inch (DN40) DV-5 Deluge Valve by a 2 x 1-1/2 inch Figure 716 Reducing Coupling.

### Valve Trim

The Double Interlock Preaction System with Electric/Electric Actuation Trim (Fig. 3A or 3B) forms a part of the laboratory listings and approvals. The trim is necessary for proper operation of the DV-5 Valve.

Each package of trim includes the following items:

- Water Supply Pressure Gauge
- Diaphragm Chamber Pressure Gauge
- Diaphragm Chamber Connections
- Manual Control Station
- Main Drain Valve
- System Drain Valve
- Alarm Test Valve
- Automatic Drain Valve

- System Air Pressure Gauge
- Air Supply Connections
- Low Air Pressure Alarm Switch
- Waterflow Pressure Alarm Switch (PS10-2)

The following three items and all items listed above are included in the Pre-trimmed Valve Assembly and can be ordered separately for the valve trim:

- 24VDC Solenoid
- Model BFV-N Butterfly Valve
- Figure 577 Grooved Coupling

To ease field assembly of the trim arrangement, the trim components are provided partially assembled as shown in Figure 3B.

The trim arrangement is provided with galvanized or black nipples and fittings. The galvanized trim is intended for non-corrosive or corrosive conditions, whereas the black trim is principally intended for use with AFFF systems.

**NOTE:** When the system pressure is greater than 175 psi (12,1 bar), provision is to be made to replace the standard order 300 psi (20,7 bar) Water Pressure Gauges, shown in Figure 3A or 3B with separately ordered 600 psi (41,4 bar) Water Pressure Gauges.

### System Design Considerations

Because a double interlock preaction system requires time for a drop in system air pressure to occur (concurrently with the response time for the separate fire detection system) before it will allow water to enter the system piping, this system has characteristics

similar to a dry pipe sprinkler system. Therefore, the system design considerations for a dry pipe system are normally applied to a double interlock preaction system, — including: a 30% increase in design area; a maximum 1 minute water delivery time for system capacities of 750 gallons (2800 liters) or more; and, prohibition of gridded system piping.

As an option, the DV-5 Double Interlock Preaction System with Electric/Electric Actuation may be equipped with the Model QRS Electronic Accelerator to reduce the time to valve actuation following the operation of the electric detection system and one or more automatic sprinklers. Refer to Technical Data Sheet TFP1100 for details regarding installation requirements and pressure ratings.

In order to readily perform the System Inspection Procedure described in the Care and Maintenance section, it is recommended that a System Shut-Off Valve be installed above the Riser Check Valve, as shown in Figure 1. The System Shut-Off Valve should be a listed or approved (as appropriate) indicating valve with a supervisory switch to monitor the normally open position.

### Detection System

The Double Interlock Preaction System With Electric/Electric Actuation Trim provides for electric operation of the DV-5 Valve by a detection system consisting of electrical devices such as heat sensitive thermostats, smoke detectors, and/or electric manual pull stations. Information on the various types of separately ordered Solenoid Valves that may be used with this trim package is given in Technical Data Sheet TFP2180. Nominal installation dimensions for the Double Interlock Preaction System With Electric/Electric Actuation Trim are shown in Figure 4.

The cross-zone deluge valve releasing panel (automatic control unit) with battery back-up, fire detection devices, manual pull stations, and signaling devices, that are utilized with the Double Interlock Preaction System with Electric/Electric Actuation must be UL Listed, ULC Listed, C-UL Listed, or FM Approved, as applicable.

**NOTES:** Approval by Factory Mutual is contingent on the use of an FM Approved 24VDC Solenoid Valve (P/N 52-287-1-024 or P/N 52-287-1-124). FM only approves solenoid valves for use in non-hazardous locations.

Consult with the authority having jurisdiction regarding installation criteria pertaining to electric actuation circuitry.



NO.	DESCRIPTION	QTY.	P/N
1	300 psi/ 2000 kPa Water Pressure Gauge	2	92-343-1-005
2	1/4" Gauge Test Valve	1	46-005-1-002
3	Model MC-1 Manual Control Station	1	52-289-2-001
4	Model AD-1 Automatic Drain Valve	1	52-793-2-004
5	Model ASV-1 Automatic Shut-Off Valve	1	92-343-1-021
6	Waterflow Pressure Alarm Switch, Model PS10-2	1	25710
7	1/2" Ball Valve	2	46-050-1-004
8	1/2" Spring Loaded Check Valve	1	92-322-1-002
9	1/2" Y-Strainer	1	52-353-1-005
10	3/4" Swing Check Valve	1	46-049-1-005
11	3/4" Angle Valve	1	46-048-1-005
12	Drip Funnel Connector	1	92-211-1-005
13	Drip Funnel Bracket	1	92-211-1-003
14	Drip Funnel	1	92-343-1-007
15	3/32" Vent Fitting	1	92-032-1-002
16	1/4" x 18" Tubing	1	CH
17	1/2" Tubing Connector	1	CH
18	1/2" x 12" Tubing	1	CH
19	1/4" Plug	1	CH
20	3/4" Plug	1	CH
21	1/2" Union	5	CH
22	3/4" Union	1	CH
23	1/4" 90° Elbow	1	CH

NO.	DESCRIPTION	QTY.	P/N
24	1/2" 90° Elbow	7	CH
25	3/4" 90° Elbow	1	CH
26	3/4" x 1/2" 90° Elbow	1	CH
27	1/2" Tee	3	CH
28	1/2" x 1/4" x 1/2" Tee	3	CH
29	3/4" Tee	1	CH
30	3/4" x 1/2" x 3/4" Tee	2	CH
31	1/4" x Close Nipple	2	CH
32	1/2" x Close Nipple	3	CH
33	1/2" x 1-1/2" Nipple	11	CH
34	1/2" x 2" Nipple	1	CH
35	1/2" x 2-1/2" Nipple	3	CH
36	1/2" x 5" Nipple	2	CH
37	1/2" x 7" Nipple	1	CH
38	Select Nipple per Table	1	CH
39	Select Nipple per Table	1	CH
40	3/4" x 1-1/2" Nipple	6	CH
41	3/4" x 2" Nipple	1	CH
42	3/4" x 4" Nipple	1	CH
P1	250 psi/ 1750 kPa Air Pressure Gauge	1	92-343-1-012
P2	1/4" Gauge Test Valve	1	46-005-1-002
P3	Low Air Pressure Alarm Switch, Model PS10-2	1	25710

NO.	DESCRIPTION	QTY.	P/N
P4	1/4" Pressure Relief Valve	1	92-343-1-020
P5	1/2" Swing Check Valve	1	46-049-1-004
P6	1/2" Globe Valve	1	46-047-1-004
P7	3/4" Angle Valve	1	46-048-1-007
P8	1/4" Plug	3	CH
P9	1/2" x 1/4" Reducing Bushing	1	CH
P10	1/2" Union	1	CH
P11	1/2" 90° Elbow	1	CH
P12	1/2" Cross	1	CH
P13	1/2" x 1/2" x 1/4" Tee	1	CH
P14	1" x 3/4" x 1/2" Tee	1	CH
P15	1/4" x 3" Nipple	1	CH
P16	1/2" x 1-1/2" Nipple	5	CH
P17	1/2" x 7-1/2" Nipple	1	CH
P18	3/4" x 1-1/2" Nipple	1	CH
P19	1" x 2" Nipple	1	CH

E1	Item No. Not Used		
E2	1/2" Tubing Connector	1	CH
E3	1/2" x 24" Tubing	1	CH
E4	1/2" x 1-1/2" Nipple	1	CH

COMPONENTS INCLUDED ONLY IN PRE-TRIMMED VALVE ASSEMBLIES:

A1	Model CV-1FR Check Valve, 2" (DN50)	1	59-590-1-020
A2	Butterfly Valve, Power Ball 300:		
	1-1/2" (DN40)	1	51024A
	2" (DN50)	1	51021A
A3	Figure 577 Coupling:		
	1-1/2" (DN40)	1	57715ACP
	2" (DN50)	1	57720ACP
A4	Coupling for 1-1/2" (DN40) DV-5:		
	Figure 716 Reducing Coupling, 2" x 1-1/2"	1	7162015ES
	Coupling for 2" (DN50) DV-5:		
	Figure 577 Coupling, 2"	1	57720ACP
A5	Solenoid Valve	1	52-287-1-024

Nipple Number	Select Appropriate Nipple Sizes per DV-5 Deluge Valve Size	
	1-1/2" (DN40)	2" (DN50)
38	1/2" x Close	1/2" x 2"
39	1/2" x 5"	1/2" x 5-1/2"

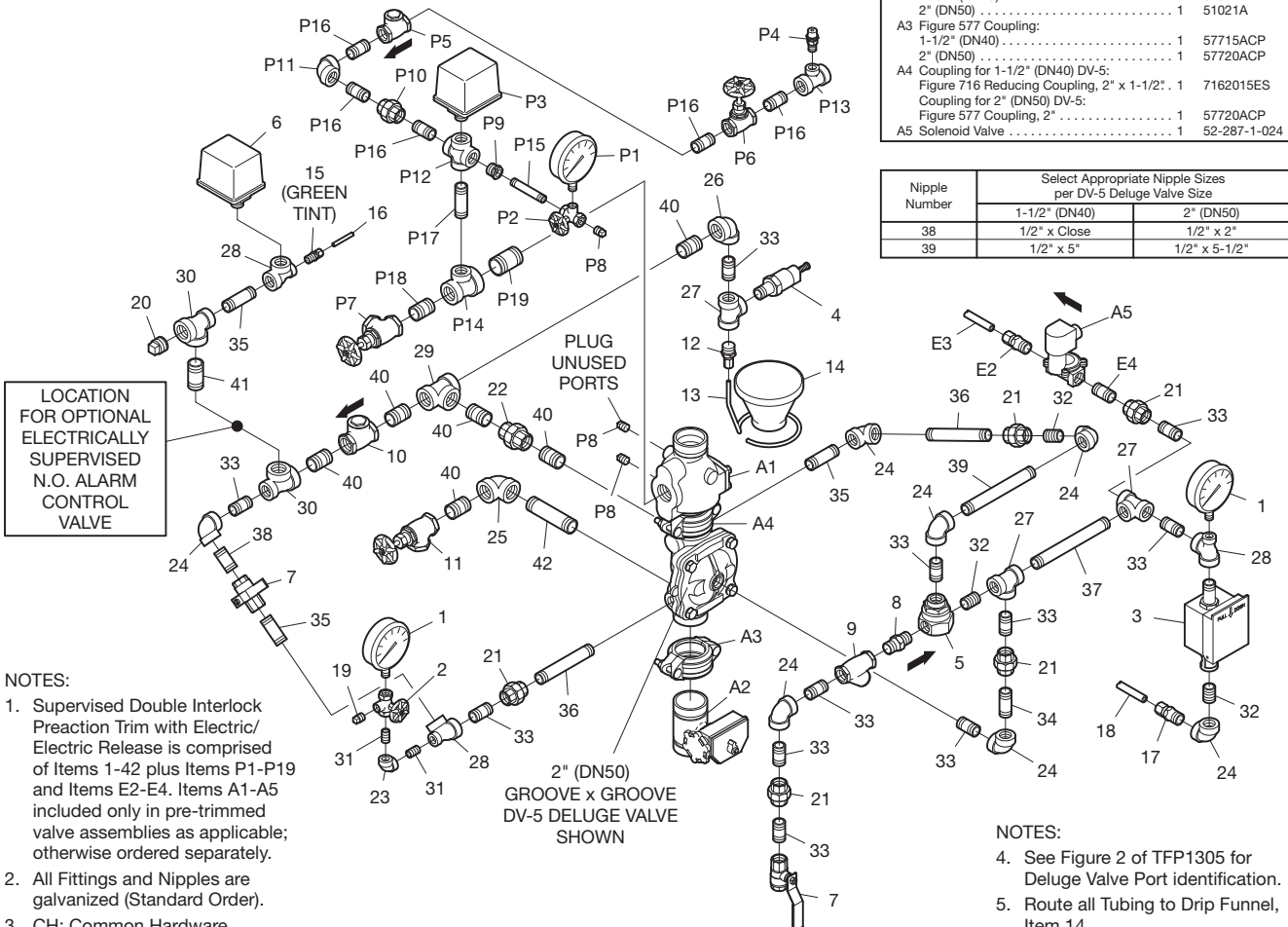

- NOTES:
- Supervised Double Interlock Preaction Trim with Electric/Electric Release is comprised of Items 1-42 plus Items P1-P19 and Items E2-E4. Items A1-A5 included only in pre-trimmed valve assemblies as applicable; otherwise ordered separately.
  - All Fittings and Nipples are galvanized (Standard Order).
  - CH: Common Hardware.

- NOTES:
- See Figure 2 of TFP1305 for Deluge Valve Port identification.
  - Route all Tubing to Drip Funnel, Item 14.

**FIGURE 3A (1 OF 3)**  
**1-1/2 AND 2 INCH (DN40 AND DN50) DV-5 DOUBLE INTERLOCK PREACTION SYSTEM WITH ELECTRIC/ELECTRIC ACTUATION TRIM WITHOUT MODEL QRS ELECTRONIC ACCELERATOR EXPLODED VIEW**

NO.	DESCRIPTION	QTY.	P/N
1	300 psi/ 2000 kPa Water Pressure Gauge	2	92-343-1-005
2	1/4" Gauge Test Valve	1	46-005-1-002
3	Model MC-1 Manual Control Station	1	52-289-2-001
4	Model AD-1 Automatic Drain Valve	1	52-793-2-004
5	Model ASV-1 Automatic Shut-Off Valve	1	92-343-1-021
6	Waterflow Pressure Alarm Switch, Model PS10-2	1	25710
7	1/2" Ball Valve	2	46-050-1-004
8	1/2" Spring Loaded Check Valve	1	92-322-1-002
9	1/2" Y-Strainer	1	52-353-1-005
10	3/4" Swing Check Valve	1	46-049-1-005
11	1-1/4" Angle Valve	1	46-048-1-007
12	Drip Funnel Connector	1	92-211-1-005
13	Drip Funnel Bracket	1	92-211-1-003
14	Drip Funnel	1	92-343-1-007
15	3/32" Vent Fitting	1	92-032-1-002
16	1/4" x 18" Tubing	1	CH
17	1/2" Tubing Connector	1	CH

NO.	DESCRIPTION	QTY.	P/N
18	1/2" x 18" Tubing	1	CH
19	1/4" Plug	1	CH
20	3/4" Plug	1	CH
21	1/2" Union	5	CH
22	3/4" Union	1	CH
23	1/4" 90° Elbow	1	CH
24	1/2" 90° Elbow	7	CH
25	3/4" x 1/2" 90° Elbow	1	CH
26	1-1/4" 90° Elbow	1	CH
27	1/2" Tee	3	CH
28	1/2" x 1/4" x 1/2" Tee	3	CH
29	3/4" Tee	1	CH
30	3/4" x 1/2" x 3/4" Tee	2	CH
31	1/4" x Close Nipple	2	CH
32	1/2" x Close Nipple	2	CH
33	1/2" x 1-1/2" Nipple	13	CH
34	1/2" x 2-1/2" Nipple	1	CH
35	1/2" x 3-1/2" Nipple	1	CH

NO.	DESCRIPTION	QTY.	P/N
36	1/2" x 4" Nipple	1	CH
37	1/2" x 4-1/2" Nipple	1	CH
38	1/2" x 5" Nipple	1	CH
39	1/2" x 5-1/2" Nipple	1	CH
40	1/2" x 7" Nipple	2	CH
41	3/4" x 1-1/2" Nipple	5	CH
42	3/4" x 2" Nipple	1	CH
43	1-1/4" x 2" Nipple	1	CH
44	1-1/4" x 4" Nipple	1	CH

P1	250 psi/ 1750 kPa Air Pressure Gauge	1	92-343-1-012
P2	1/4" Gauge Test Valve	1	46-005-1-002
P3	Low Air Pressure Alarm Switch, Model PS10-2	1	25710
P4	1/4" Pressure Relief Valve	1	92-343-1-020
P5	1/2" Swing Check Valve	1	46-049-1-004
P6	1/2" Globe Valve	1	46-047-1-004
P7	1-1/4" Angle Valve	1	46-048-1-007
P8	1/4" Plug	3	CH
P9	1/2" x 1/4" Reducing Bushing	1	CH
P10	1/2" Union	1	CH
P11	1/2" 90° Elbow	1	CH
P12	1/2" Cross	1	CH
P13	1/2" x 1/2" x 1/4" Tee	1	CH
P14	1-1/4" x 1-1/4" x 1/2" Tee	1	CH
P15	1/4" x 3" Nipple	1	CH
P16	1/2" x 1-1/2" Nipple	6	CH
P17	1-1/4" x 2" Nipple	1	CH
P18	1-1/4" x 3" Nipple	1	CH

E1	Item No. Not Used		
E2	1/2" Tubing Connector	1	CH
E3	1/2" x 24" Tubing	1	CH
E4	1/2" x 1-1/2" Nipple	1	CH

COMPONENTS INCLUDED ONLY IN PRE-TRIMMED VALVE ASSEMBLIES:

A1	Model CV-1FR Check Valve, 3" (DN80)	1	59-590-1-030
A2	Model BFV-N Butterfly Valve, 3" (DN80)	1	59300F030N
A3	Figure 577 Coupling, 3" (DN80)	2	57730ACP
A4	Solenoid Valve	1	52-287-1-024

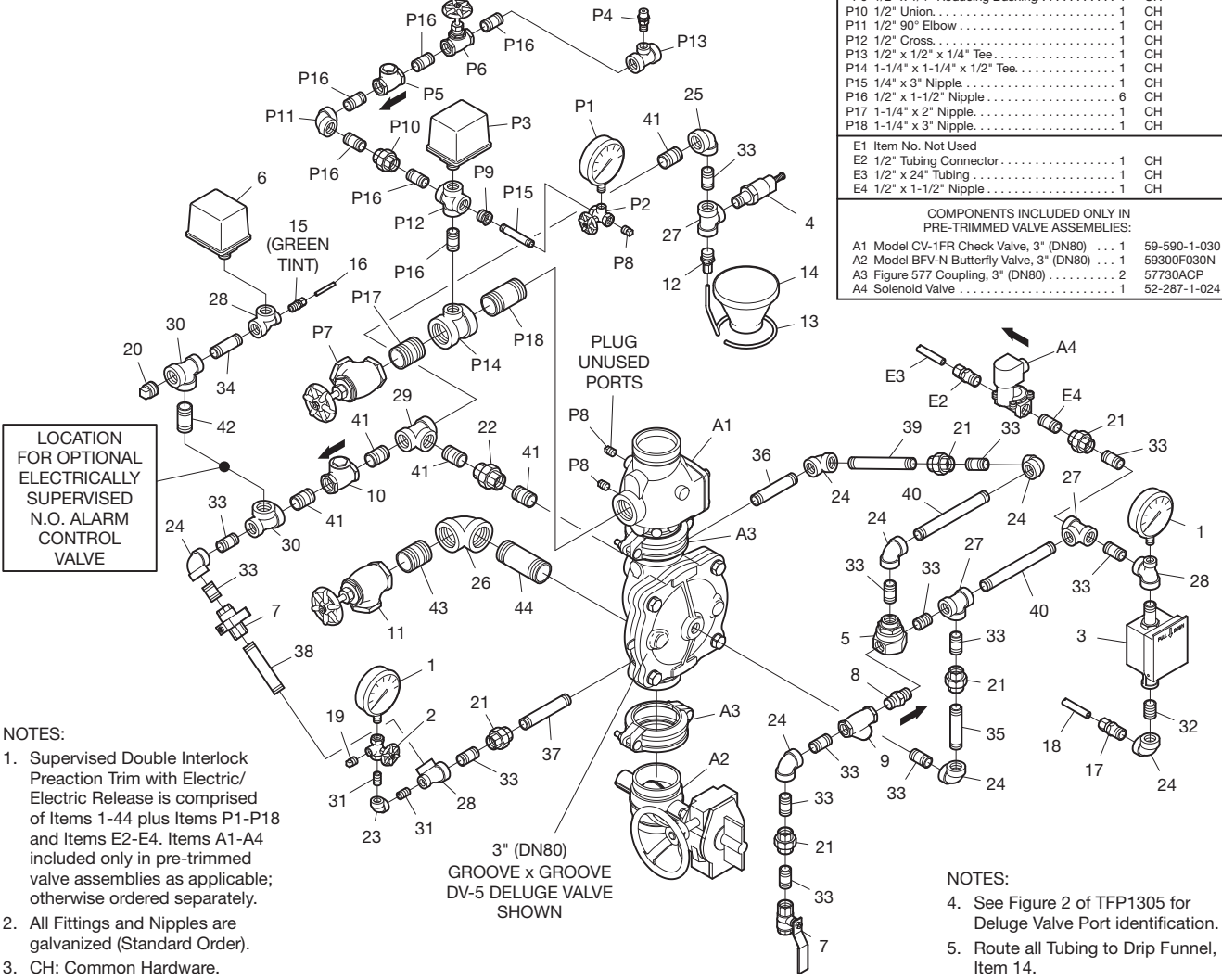

- NOTES:
- Supervised Double Interlock Preaction Trim with Electric/Electric Release is comprised of Items 1-44 plus Items P1-P18 and Items E2-E4. Items A1-A4 included only in pre-trimmed valve assemblies as applicable; otherwise ordered separately.
  - All Fittings and Nipples are galvanized (Standard Order).
  - CH: Common Hardware.

- NOTES:
- See Figure 2 of TFP1305 for Deluge Valve Port identification.
  - Route all Tubing to Drip Funnel, Item 14.

**FIGURE 3A (2 OF 3)**  
**3 INCH (DN80) DV-5 DOUBLE INTERLOCK PREACTION SYSTEM WITH ELECTRIC/ELECTRIC ACTUATION TRIM WITHOUT MODEL QRS ELECTRONIC ACCELERATOR EXPLODED VIEW**

NO.	DESCRIPTION	QTY.	P/N
1	300 psi/ 2000 kPa Water Pressure Gauge	2	92-343-1-005
2	1/4" Gauge Test Valve	1	46-005-1-002
3	Model MC-1 Manual Control Station	1	52-289-2-001
4	Model AD-1 Automatic Drain Valve	1	52-793-2-004
5	Model ASV-1 Automatic Shut-Off Valve	1	92-343-1-021
6	Waterflow Pressure Alarm Switch, Model PS10-2	1	25710
7	1/2" Ball Valve	2	46-050-1-004
8	1/2" Spring Loaded Check Valve	1	92-322-1-002
9	1/2" Y-Strainer	1	52-353-1-005
10	3/4" Swing Check Valve	1	46-049-1-005
11	Item No. Not Used		
12	2" Angle Valve	1	46-048-1-009
13	Drip Funnel Connector	1	92-211-1-005
14	Drip Funnel Bracket	1	92-211-1-003
15	Drip Funnel	1	92-343-1-007
16	3/32" Vent Fitting	1	92-032-1-002
17	1/4" x 24" Tubing	1	CH
18	1/2" Tubing Connector	1	CH
19	1/2" x 24" Tubing	1	CH
20	1/4" Plug	1	CH
21	3/4" Plug	1	CH
22	1/2" Union	5	CH
23	1" Union	1	CH
24	1/4" 90° Elbow	1	CH
25	1/2" 90° Elbow	7	CH
26	1/2" Tee	3	CH
27	1/2" x 1/4" x 1/2" Tee	3	CH

NO.	DESCRIPTION	QTY.	P/N
28	3/4" x 1/2" x 3/4" Tee	2	CH
29	1" x 1/2" 90° Elbow	1	CH
30	1" x 3/4" x 1" Tee	1	CH
31	2" 90° Elbow	1	CH
32	1/4" x Close Nipple	2	CH
33	1/2" x Close Nipple	2	CH
34	1/2" x 1-1/2" Nipple	10	CH
35	1/2" x 2-1/2" Nipple	2	CH
36	1/2" x 3" Nipple	1	CH
37	1/2" x 5" Nipple	2	CH
38	1/2" x 8" Nipple	1	CH
39	1/2" x 7" Nipple	1	CH
40	Select Nipple per Table	1	CH
41	Select Nipple per Table	1	CH
42	Select Nipple per Table	1	CH
43	3/4" x 2-1/2" Nipple	1	CH
44	3/4" x 2" Nipple	1	CH
45	Select Nipple per Table	1	CH
46	1" x Close Nipple	2	CH
47	1" x 3" Nipple	1	CH
48	Item No. Not Used		
49	2" x 3" Nipple	2	CH
50	1/2" x 9" Nipple	1	CH
P1	250 psi/ 1750 kPa Air Pressure Gauge	1	92-343-1-012
P2	1/4" Gauge Test Valve	1	46-005-1-002
P3	Low Air Pressure Alarm Switch, Model PS10-2	1	25710

NO.	DESCRIPTION	QTY.	P/N
P4	1/4" Pressure Relief Valve	1	92-343-1-020
P5	1/2" Swing Check Valve	1	46-049-1-004
P6	1/2" Globe Valve	1	46-047-1-004
P7	2" Angle Valve	1	46-048-1-009
P8	1/4" Plug	3	CH
P9	1/2" x 1/4" Reducing Bushing	1	CH
P10	1/2" Union	1	CH
P11	1/2" 90° Elbow	1	CH
P12	1/2" Cross	1	CH
P13	1/2" x 1/2" x 1/4" Tee	1	CH
P14	2" x 2" x 1/2" Tee	1	CH
P15	1/4" x 3" Nipple	1	CH
P16	1/2" x 1-1/2" Nipple	6	CH
P17	2" x 3" Nipple	2	CH

E1	Item No. Not Used		
E2	1/2" Tubing Connector	1	CH
E3	1/2" x 24" Tubing	1	CH
E4	1/2" x 1-1/2" Nipple	1	CH

COMPONENTS INCLUDED ONLY IN PRE-TRIMMED VALVE ASSEMBLIES:

A1	Model CV-1FR Check Valve:		
4"	(DN100)	1	59-590-1-040
6"	(DN150)	1	59-590-1-060
8"	(DN200)	1	59-590-1-080
A2	Model BFV-N Butterfly Valve:		
4"	(DN100)	1	59300F040N
6"	(DN150)	1	59300F060N
8"	(DN200)	1	59300F080N
A3	Figure 577 Coupling:		
4"	(DN100)	2	57740ACP
6"	(DN150)	2	57760ACP
8"	(DN200)	2	57780ACP
A4	Solenoid Valve	1	52-287-1-024

Nipple No.	Select Appropriate Nipple Sizes per DV-5 Deluge Valve Size		
	4" (DN100)	6" (DN150)	8" (DN200)
40	1/2" x 2-1/2"	1/2" x 5-1/2"	1/2" x 8-1/2"
41	1/2" x 2"	1/2" x 3"	1/2" x 3-1/2"
42	1/2" x 6-1/2"	1/2" x 7-1/2"	1/2" x 9"
45	3/4" x 2-1/2"	3/4" x 3-1/2"	3/4" x 4-1/2"

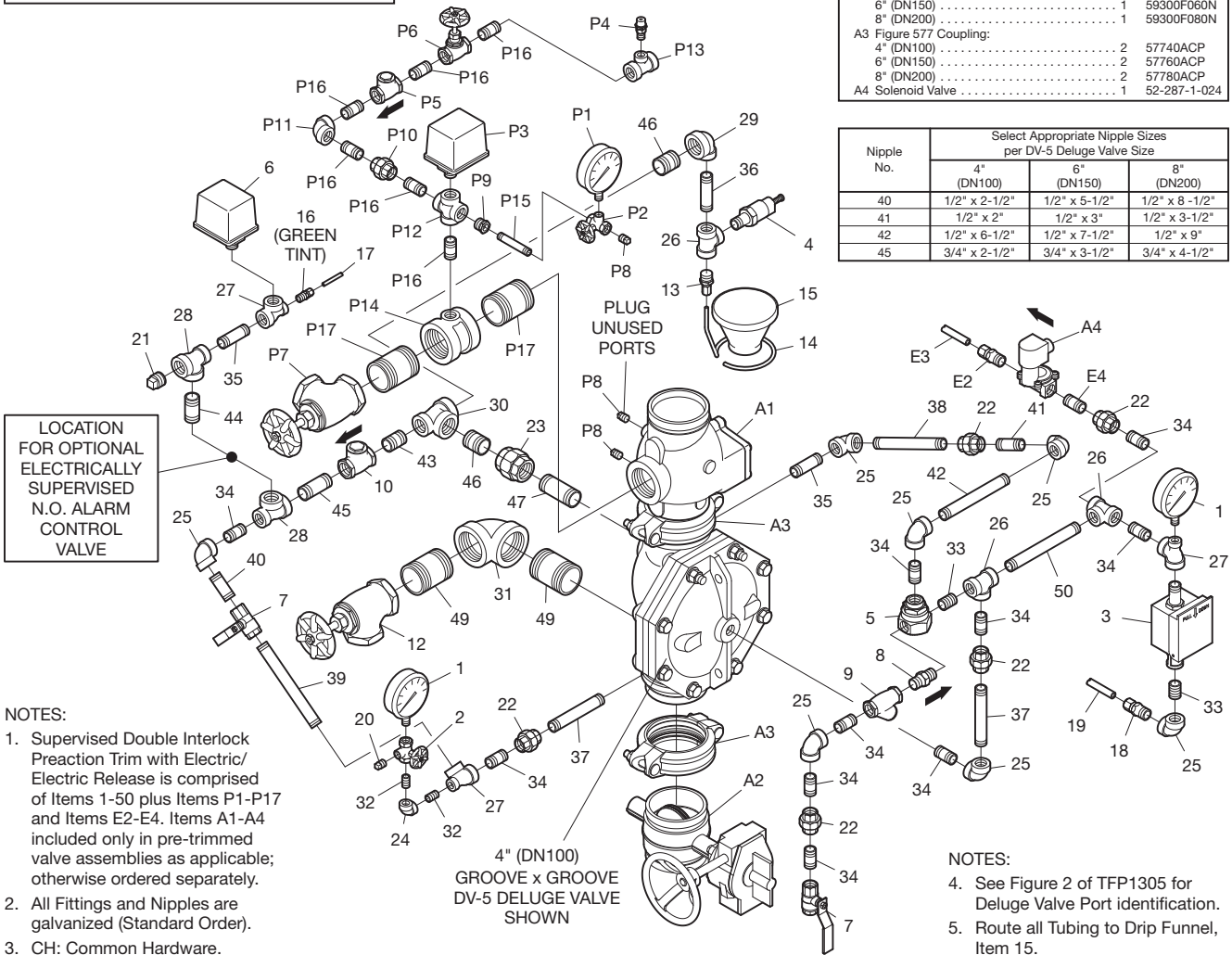

- NOTES:
- Supervised Double Interlock Preaction Trim with Electric/Electric Release is comprised of Items 1-50 plus Items P1-P17 and Items E2-E4. Items A1-A4 included only in pre-trimmed valve assemblies as applicable; otherwise ordered separately.
  - All Fittings and Nipples are galvanized (Standard Order).
  - CH: Common Hardware.

- NOTES:
- See Figure 2 of TFP1305 for Deluge Valve Port identification.
  - Route all Tubing to Drip Funnel, Item 15.

**FIGURE 3A (3 OF 3)**  
**4, 6, AND 8 INCH (DN100, DN150, AND DN200) DV-5 DOUBLE INTERLOCK PREACTION SYSTEM WITH ELECTRIC/ELECTRIC ACTUATION TRIM WITHOUT MODEL QRS ELECTRONIC ACCELERATOR EXPLODED VIEW**

**NOTES:**

1. Use only 2" (DN50) Model CV-1FR Riser Check Valve in 1-1/2" (DN40) and 2" (DN50) assemblies. Use CV-1FR Valve size equal to mating DV-5 Valve in larger assemblies.
2. Nipples 1-4 vary in length relative to DV-5 size. Select per table. All other nipples packed unassembled shall be installed per appropriate trim exploded view, Figure 3A Part 1, 2, or 3.
3. Install subassemblies in alphabetical order.
4. See Figure 2 of TFP1305 for Deluge Valve Port identification.
5. Route all Tubing to Drip Funnel.

Nipple Number	Select Appropriate Nipple Sizes per DV-5 Deluge Valve Size					
	1-1/2" (DN40)	2" (DN50)	3" (DN80)	4" (DN100)	6" (DN150)	8" (DN200)
1	1/2" x Close	1/2" x 2"	1/2" x 1-1/2"	1/2" x 2-1/2"	1/2" x 5-1/2"	1/2" x 8-1/2"
2	1/2" x Close	1/2" x Close	1/2" x 1-1/2"	1/2" x 2"	1/2" x 3"	1/2" x 3-1/2"
3	1/2" x 5"	1/2" x 5-1/2"	1/2" x 7"	1/2" x 6-1/2"	1/2" x 7-1/2"	1/2" x 9"
4	3/4" x 1-1/2"	3/4" x 1-1/2"	3/4" x 1-1/2"	3/4" x 2-1/2"	3/4" x 3-1/2"	3/4" x 4-1/2"
System Main Drain Size	3/4" NPT	3/4" NPT	1-1/4" NPT	2" NPT	2" NPT	2" NPT
Main Drain Size	3/4" NPT	3/4" NPT </tr				

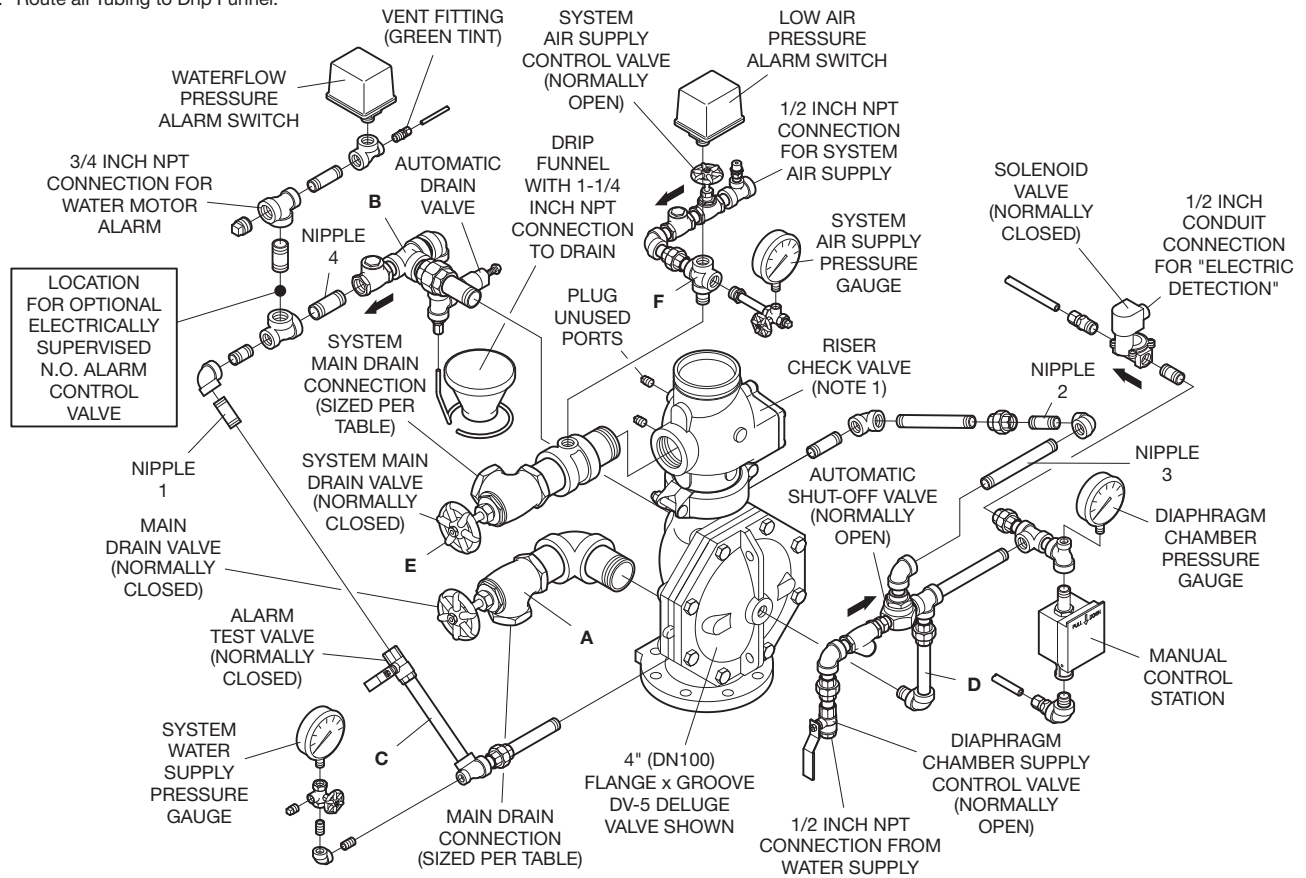
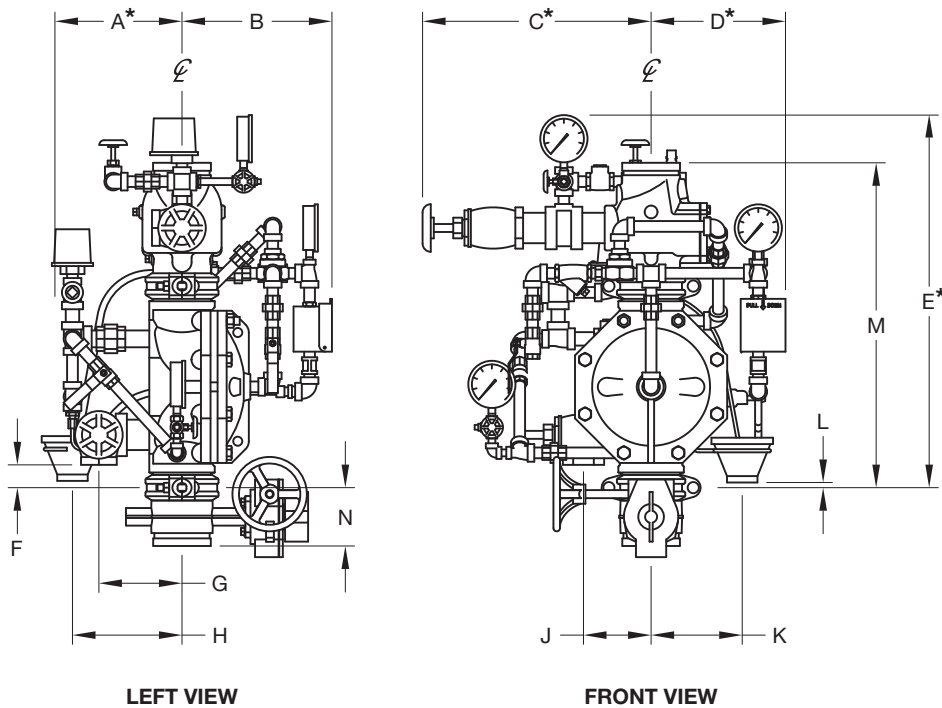

**FIGURE 3B**  
**1-1/2 THRU 8 INCH (DN40 THRU DN200) DV-5 DOUBLE INTERLOCK PREACTION SYSTEM WITH ELECTRIC/ELECTRIC ACTUATION TRIM WITHOUT MODEL QRS ELECTRONIC ACCELERATOR OPERATIONAL COMPONENTS SEMI-PREASSEMBLED TRIM EXPLODED ARRANGEMENT**



Valve Size	Nominal Installation Dimensions in Inches and (mm)												
	A	B	C	D	E	F	G	H	J	K	L	M	N
1-1/2" (DN40)	7.00 (177,8)	8.88 (225,4)	13.00 (330,2)	10.50 (266,7)	25.50 (647,7)	4.00 (101,6)	5.81 (147,6)	5.81 (147,6)	3.00 (76,2)	7.00 (177,8)	4.00 (101,6)	14.81 (376,2)	4.02 (102,1)
2" (DN50)	7.13 (181,0)	9.13 (231,8)	13.00 (330,2)	10.50 (266,7)	26.06 (661,9)	3.13 (79,4)	6.00 (152,4)	6.00 (152,4)	3.00 (76,2)	7.00 (177,8)	3.13 (79,4)	15.38 (390,5)	4.09 (103,9)
3" (DN80)	7.81 (198,4)	10.44 (265,1)	14.50 (368,3)	10.50 (266,7)	25.00 (635,0)	1.69 (42,9)	6.69 (170,0)	6.69 (170,0)	4.25 (108,0)	7.00 (177,8)	0.25 (6,4)	21.13 (536,6)	3.85 (98,0)
4" (DN100)	10.00 (254,0)	11.75 (298,5)	17.88 (454,0)	12.50 (317,5)	29.13 (739,8)	1.75 (44,5)	6.50 (165,1)	8.56 (217,5)	6.25 (158,8)	7.13 (181,0)	0.38 (9,5)	25.38 (644,5)	4.56 (116,0)
6" (DN150)	11.38 (289,0)	14.31 (363,5)	18.75 (476,3)	12.50 (317,5)	31.94 (811,2)	3.50 (88,9)	7.88 (200,0)	9.94 (252,4)	6.25 (158,8)	7.13 (181,0)	1.56 (39,7)	29.63 (752,5)	5.86 (149,0)
8" (DN200)	12.00 (304,8)	16.00 (406,4)	21.25 (539,8)	12.50 (317,5)	36.75 (933,5)	1.75 (44,5)	10.75 (273,1)	10.63 (269,9)	6.25 (158,8)	7.13 (181,0)	7.13 (181,0)	36.50 (927,1)	5.26 (134,0)

\* MINIMUM CLEARANCE



**FIGURE 4**  
**1-1/2 THRU 8 INCH (DN40 AND DN200) DV-5 DOUBLE INTERLOCK PREACTION SYSTEM WITH ELECTRIC/ELECTRIC ACTUATION TRIM WITH OR WITHOUT MODEL QRS ELECTRONIC ACCELERATOR NOMINAL INSTALLATION DIMENSIONS**

The Double Interlock Preaction System With Electric/Electric Actuation Trim is provided with a Model ASV-1 Automatic Shut-Off Valve (Item 5 -Fig. 3A); consequently, the release circuit of the Releasing Panel need only provide the standard ten minutes of alarm condition intended to energize the Solenoid Valve to open. After the ten minute duration, at which point should the Solenoid Valve become de-energized and close (especially while operating under battery back-up), the Automatic Shut-Off Valve will have already automatically closed, thereby preventing the DV-5 Diaphragm Chamber from becoming re-pressurized and preventing an inadvertent closing of the DV-5 during a fire event.

#### **System Air Pressure Requirements**

The recommended system air pressure for the Double Interlock Preaction System with Electric/Electric Actuation is nominally 15 psi (1,0 bar), irrespective of the water supply pressure. The use of a higher system air pressure may increase water delivery time, and the use of a lower system air pressure may prevent clearing the alarm of the Low Air Pressure Alarm Switch (Item P3 -Fig. 3A) on increasing pressure. The Low Pressure Alarm Switch is field set to alarm at nominally 12 psi (0,8 bar) on decreasing pressure. It is recommended that the system air pressure be maintained by either of the following methods:

- A maximum 200 psi (13,8 bar) plant air supply in combination with the Model AMD-1 Air Maintenance Device described in Technical Data Sheet TFP1221
- A maximum 3000 psi (206,9 bar) nitrogen cylinder in combination with the Model AMD-3 Nitrogen Maintenance Device described in Technical Data Sheet TFP1241

**NOTES:** *It is recommended that the pressure maintenance device be of a type that maintains a constant system pressure, i.e., a pressure maintenance device that utilizes a pressure regulator versus a pressure switch (e.g., the AMD-1 or AMD-3). Use of a pressure switch operated pressure maintenance device with a cut-in/cut-out differential may result in a delay in the operation of the system due to a fire, because of the cut-out pressure being higher than the recommended nominal system air pressure.*

*The dew point of the air or nitrogen supply, for a system exposed to freezing conditions, must be maintained below the lowest ambient temperature to which the system piping will be*

*exposed. Introduction of moisture into the system piping can create ice build up which could prevent proper operation of the system.*

The Pressure Relief Valve (Item P4 - Fig. 3A) is typically field set to crack open at a pressure of about 20 psi (1,4 bar).

#### **Friction Loss**

The nominal pressure loss versus flow data for the DV-5 Deluge Valve plus Riser Check Valve is provided in Graph A.

## **Installation**

### **NOTICE**

*1-1/2 inch (DN40) risers utilize a 2 inch (DN50) Riser Check Valve in combination with the 1-1/2 (DN40) DV-5 Deluge Valve.*

*Proper operation of the DV-5 Deluge Valve depends upon its trim being installed in accordance with the instructions given in this technical data sheet. Failure to follow the appropriate trim diagram may prevent the DV-5 Valve from functioning properly, as well as void listings, approvals, and the manufacturer's warranties.*

*Field adjustments of the Air Maintenance Device, Low Pressure Alarm Switch, and Pressure Relief Valve are required. The Air Maintenance Device and the Low Pressure Alarm Switch should be set as close as possible to the specified settings in order to minimize water delivery time.*

*When using compressed air as opposed to compressed nitrogen for refrigerated area service, alternate air supply connections with an air dryer may be required by the authority having jurisdiction. The "1/2 Inch NPT Connection For System Air Supply" shown in Figure 3B is to be plugged when using an alternate air supply connection; the location of the Air Pressure Maintenance is to be as specified by the authority having jurisdiction; and, Step 10 regarding the adjustment of the Pressure Relief Valve can be omitted, since the Pressure Relief Valve in this case will be ineffective.*

*The DV-5 Valve must be installed in a readily visible and accessible location.*

*The DV-5 Valve and associated trim must be maintained at a minimum temperature of 40°F (4°C).*

*Heat tracing of the DV-5 Valve or its associated trim is not permitted. Heat tracing can result in the formation of hardened mineral deposits that can prevent proper operation.*

The TYCO DV-5 Deluge Valve is to be installed in accordance with the following criteria:

**Step 1.** All nipples, fittings, and devices must be clean and free of scale and burrs before installation. Use pipe thread sealant sparingly on male pipe threads only.

**Step 2.** The DV-5 Valve must be trimmed in accordance with Figure 3A or 3B (or TFP1100 when using Model QRS Electronic Accelerator).

**Step 3.** Care must be taken to ensure that check valves, strainers, globe valves, etc. are installed with the flow arrows in the proper direction.

**Step 4.** Drain tubing to the drip funnel must be installed with smooth bends that will not restrict flow.

**Step 5.** The main drain and drip funnel drain may be interconnected provided a check valve is located at least 12 inches (300 mm) below the drip funnel.

**Step 6.** Suitable provision must be made for disposal of drain water. Drainage water must be directed so that it will not cause accidental damage to property or danger to persons.

**Step 7.** Connect the Diaphragm Chamber Supply Control Valve to the inlet side of the system's main control valve in order to facilitate setting of the DV-5 Valve (Fig. 4).

**Step 8.** Unused pressure alarm switch connections must be plugged.

**Step 9.** A suitable automatic supervisory air (nitrogen) supply, as described in the Technical Data Section, is to be installed in accordance with the applicable Technical Data Sheet and set to maintain nominally 15 psi (1,0 bar).

**Step 10.** Adjust the Pressure Relief Valve (Item P4 - Fig. 3A), as applicable, to crack open at approximately 20 psi (1,4 bar). As shipped, it is set to open at approximately 45 psi (3,1 bar).

To reset the Pressure Relief Valve, first loosen the jam nut and then adjust the cap accordingly — clockwise for a higher pressure setting or counter-clockwise for a lower pressure setting. After verifying the desired pressure setting, tighten the jam nut.

**Step 11.** Adjust the Low Pressure Alarm Switch (Item P3 - Fig. 3A) to transfer the electrical contacts at nominally 12 psi (0,8 bar) on decreasing pressure. As shipped, the switch is set to transfer the electrical contacts at approximately 5 psi (0,3 bar) on decreasing pressure.

Use the instructions provided with the switch to adjust the pressure setting.

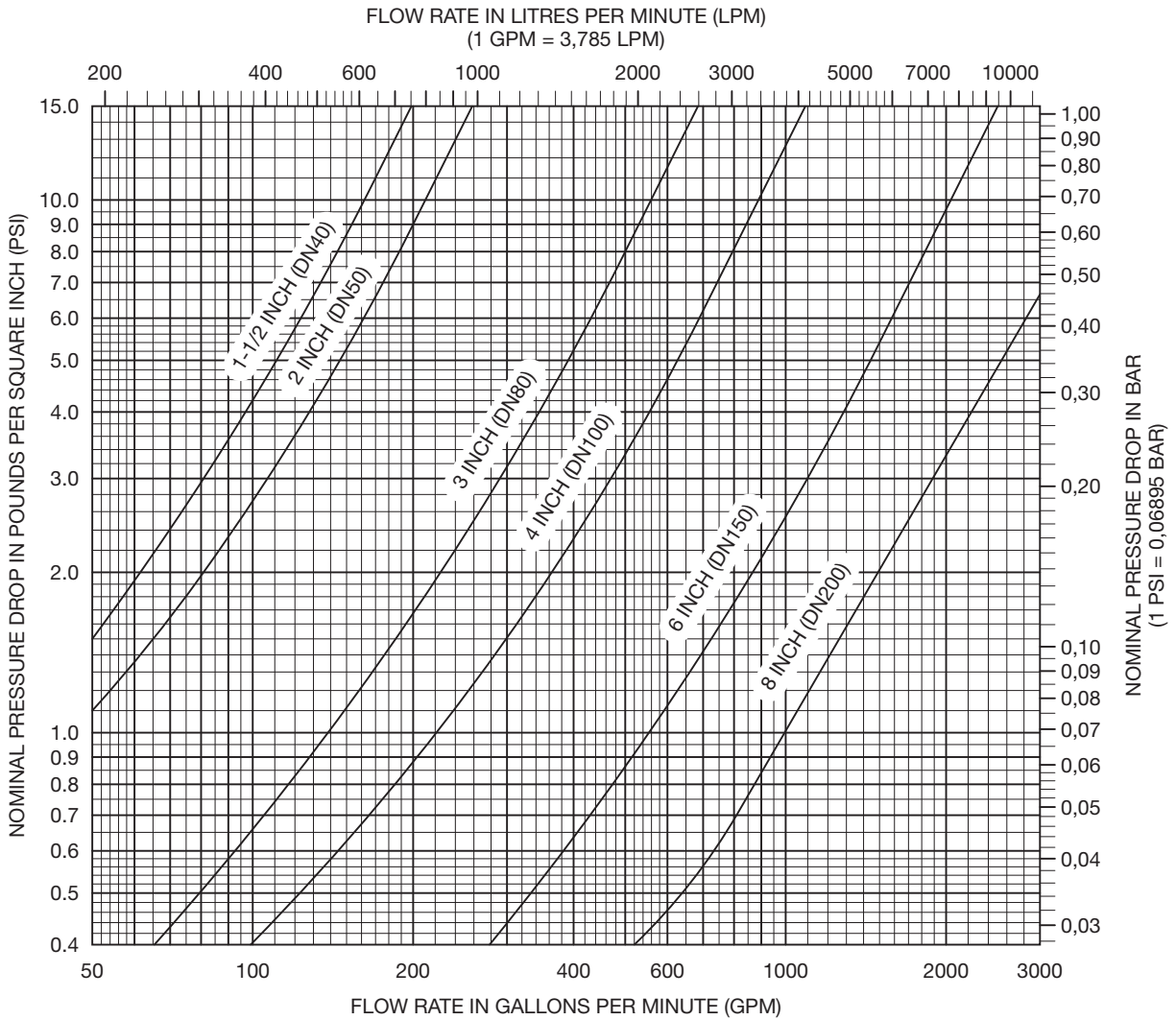

The approximate friction loss, based on the Hazen and Williams formula and expressed in equivalent length of pipe with C=120, is as follows:

- 15 feet of 1-1/2 Sch. 40 pipe for the 1-1/2 inch Valve Combination\*\*calculated on a typical flow rate of 100 gpm.
- 28 feet of 2 inch Sch. 40 pipe for the 2 inch Valve Combination\* calculated on a typical flow rate of 175 gpm.
- 37 feet of 3 inch Sch. 40 pipe for the 3 inch Valve Combination\* calculated on a typical flow rate of 350 gpm.
- 48 feet of 4 inch Sch. 40 pipe for the inch Valve Combination\* calculated on a typical flow rate of 600 gpm.
- 73 feet of 6 inch Sch. 40 pipe for the 6 inch Valve Combination\* calculated on a typical flow rate of 1500 gpm.
- 103 feet of 8 inch Sch. 30 pipe for the 8 inch Valve Combination\* calculated on a typical flow rate of 2500 gpm.

**GRAPH A**  
**DELUGE AND CHECK VALVE COMBINATION\***  
**NOMINAL PRESSURE LOSS VERSUS FLOW**

\* DV-5 Deluge Valve combined with Model CV-1FR Riser Check Valve  
\*\*1-1/2 inch DV-5 Deluge Valve combined with 2 inch Model CV-1FR Riser Check Valve

**Step 12.** Conduit and electrical connections are to be made in accordance with the requirements of the authority having jurisdiction and/or the National Electric Code.

**NOTICE**

*The heat detection devices are to be connected to the Zone 1 initiating circuit contacts of the Cross-Zone Deluge Valve Releasing Panel.*

*The Low Air Pressure Alarm Switch contacts are to be connected to the Zone 2 initiating circuit contacts of the Cross-Zone Deluge Valve Releasing Panel.*

**Step 13.** Before a system hydrostatic test is performed in accordance with NFPA 13 system acceptance test requirements, the DV-5 Diaphragm Chamber is to be depressurized; the Automatic Drain Valve (Item 4 - Fig. 3A) is to be temporarily replaced with a 1/2 inch NPT plug, the 3/32 inch Vent Fitting (Item 16 - Fig. 3A) is to be temporarily replaced with a 1/4 inch NPT plug, and the Diaphragm Cover Bolts must be uniformly and securely tightened using a cross-draw sequence. After tightening, double-check to make certain that all of the Diaphragm Cover Bolts are securely tightened.

## Valve Setting Procedure

Steps 1 through 15 are to be performed when initially setting the TYCO DV-5 Deluge Valve, after an operational test of the fire protection system, or after system operation due to a fire.

**Step 1.** Close the Main Control Valve.

**Step 2.** Close the Diaphragm Chamber Supply Control Valve and the System Air Supply Control Valve.

**Step 3.** Open the Main Drain Valve, System Drain Valve, and all auxiliary drains in the system. After water ceases to discharge, close the System Drain Valve and auxiliary drain valves. Leave the Main Drain Valve open.

**NOTE:** Do not open the Inspector's Test Connection and auxiliary drains if resetting after a system test; otherwise, system air pressure will be relieved unnecessarily.

**Step 4.** Depress the plunger of the Automatic Drain Valve to verify that it is open and that the DV-5 Valve is completely drained.

**Step 5.** Clean the Strainer in the Diaphragm Chamber Supply connection by removing the clean-out plug and strainer basket. The Strainer may be

flushed out by momentarily opening the Diaphragm Chamber Supply Control Valve.

**Step 6.** Inspect for and clear all ice plugs where system piping has been exposed to freezing conditions and when there has been a flow of water into the system.

**Step 7.** Replace all damaged or operated sprinklers. Replacement sprinklers must be of the same type and temperature rating as those that operated.

**NOTICE**

*In order to prevent the possibility of a subsequent operation of an overheated solder type sprinkler, any solder type sprinklers that were possibly exposed to a temperature greater than their maximum rated ambient must also be replaced.*

**Step 8.** Service the air dryer, if applicable, in accordance with the manufacturer's instructions.

**Step 9.** Open the System Air Supply Control Valve and allow the system to automatically re-establish its nominal air pressure of 15 psi (1,0 bar). Observe the Automatic Drain Valve for leaks. If there are leaks, determine/correct the cause of the leakage problem within the Riser Check Valve.

**Step 10.** Reset the actuation system.

**Manual Actuation** — Push the operating lever up; however, do not close the hinged cover at this time.

**Electric Actuation** — Reset the electric detection system in accordance with the manufacturer's instructions to de-energize the Solenoid Valve.

**NOTE:** For systems equipped with the Model QRS Electronic Accelerator installed per Technical Data Sheet TFP1100, momentarily press the System Reset button (Figure 6 in TFP1100). Zone 1 Alarm and Zone 2 Low Air Alarm should then clear.

**Step 11.** Open the Diaphragm Chamber Supply Control Valve and allow full pressure to build up in the Diaphragm Chamber.

**Step 12.** Operate (open) the Manual Control Station to vent trapped air from the Diaphragm Chamber. If necessary, first open the hinged cover, and then fully pull down on the operating lever. Slowly close the operating lever, by pushing it up, after aerated water ceases to discharge from the Manual Control Station drain tubing. Close the hinged cover and insert a new break rod in the small hole through the top of the enclosing box.

**Step 13.** Inspect the drain connections from the Manual Control Station and the Solenoid Valve. Any leaks must be corrected before proceeding to the next step.

**Step 14.** Verify the ability for the DV-5 Diaphragm to hold pressure as follows:

- With the diaphragm chamber pressurized per Step 12, temporarily close the Diaphragm Chamber Supply Control Valve, and monitor the Diaphragm Chamber Pressure Gauge for a drop in pressure.
- If a drop in pressure is noted, the DV-5 Diaphragm is to be replaced and/or any leaks must be corrected before proceeding to the next step.
- If the Diaphragm Chamber Pressure Gauge does not indicate a drop in pressure, re-open the Diaphragm Chamber Supply Control Valve and proceed to the next step.

**Step 15.** Slowly open the Main Control Valve. Close the Main Drain Valve as soon as water discharges from the drain connection. Observe the Automatic Drain Valve for leaks. If there are leaks, determine/correct the cause of the leakage problem. If there are no leaks, the DV-5 Valve is ready to be placed in service and the Main Control Valve must then be fully opened.

**NOTICE**

*When the Main Control Valve is opened, the pressure on the Diaphragm Chamber may increase. This increase in pressure is normal, and if the pressure is greater than 250 psi (17,2 bar), the pressure is to be relieved by partially and temporarily opening the Manual Control Station; however, do not allow the pressure as indicated on the Diaphragm Chamber Pressure Gauge to drop below the supply pressure shown on the Water Supply Pressure Gauge, since this action may result in tripping of the DV-5 Valve.*

*After setting a fire protection system, notify the proper authorities and advise those responsible for monitoring proprietary and/or central station alarms.*



## Care and Maintenance

The following procedures, inspections, and maintenance must be performed as indicated, in addition to any specific requirements of the NFPA, and any impairment must be immediately corrected.

Before closing a fire protection system main control valve for maintenance work on the fire protection system that it controls, permission to shut down the affected fire protection system must be obtained from the proper authorities and all personnel who may be affected by this action must be notified.

The owner is responsible for the inspection, testing, and maintenance of their fire protection system and devices in compliance with this document, as well as with the applicable standards of the National Fire Protection Association (e.g., NFPA 25), in addition to the standards of any authority having jurisdiction. Contact the installing contractor or product manufacturer with any questions.

Automatic sprinkler systems are recommended to be inspected, tested, and maintained by a qualified Inspection Service in accordance with local requirements and/or national codes.

It is recommended that the System Inspection Procedure be performed at least semi-annually by a qualified Inspection Service. The Double Interlock Preaction System Inspection Procedure may be followed in lieu of performing any of the operational tests recommended in the technical data sheets for the DV-5 Deluge Valve, Riser Check Valve, 24 VDC Solenoid Valve, and Model MC-1 Manual Control Station.

### NOTICE

*It is recommended that the individuals responsible for the care and maintenance of the Double Interlock Preaction System develop a working understanding of the system, in general, prior to performing inspection and/or maintenance procedures. These instructions, as well as individual instructions for the Deluge Valve, Riser Check Valve, Solenoid Valve, Manual Control Station, switches, and pressure maintenance device should be reviewed.*

*The following procedures pertain to the automatic control valve portion of the Double Interlock Preaction System. Refer to the manufacturer's instructions and NFPA 25 for care and maintenance procedures for all other devices (e.g.,*

*electric detection, main control and system shut-off valves, supervisory devices, sprinklers, etc.).*

*Before performing the System Inspection Procedure, which will result in operation of alarms, notify the proper authorities and all personnel who may be affected.*

### System Inspection Procedure

**Step 1.** Close the Main Control Valve (Fig. 1) and then open the DV-5 Main Drain Valve (Fig. 3B).

**Step 2.** Manually operate Zone 1 of the Releasing Panel, and verify the following:

- The operation of the Releasing Panel and its associated alarms
- That there is no leakage from the Solenoid Valve (Fig. 3B)

**NOTE:** *During this procedure, the Solenoid Valve should remain closed and the DV-5 Deluge Valve Diaphragm Chamber should remain pressurized.*

*This procedure is used to verify that the DV-5 Deluge Valve will remain set if the electric detection system (Zone 1) operates but the sprinkler system (Zone 2) remains in its normally pressurized condition.*

**Step 4.** Restore the electric fire detection system to a normal condition in accordance with the manufacturer's instructions.

**Step 5.** Open the Inspector's Test Connection to relieve system air pressure, and verify the following:

- That the Low Air Pressure Alarm Switch (Fig. 3B) and Zone 2 of the Releasing Panel, as well as its associated alarms, operate properly. The Low Pressure Alarm Switch should operate at approximately 12 psi (0,8 bar).
- That there is no leakage from the Solenoid Valve (Fig. 3B)

**Step 6.** Close the Inspector's Test Connection.

**NOTE:** *During this procedure, the Solenoid Valve should remain closed and the DV-5 Deluge Valve Diaphragm Chamber should remain pressurized.*

*This procedure is used to verify that the DV-5 Deluge Valve will remain set if the Low Pressure Alarm Switch (Zone 2) operates due to loss of system air pressure and the electric detection system (Zone 1) remains in a normal condition.*

**Step 7.** Restore the electric fire detection system to a normal condition in accordance with the manufacturer's instructions after the system air pressure has automatically been restored to normal.

**Step 8.** Close the System Shut-off Valve (Fig. 1).

**Step 9.** Open the Main Control Valve (Fig. 1) one turn beyond the position at which water just begins to flow from the Main Drain Valve (Fig. 3B).

**Step 10.** Close the Main Drain Valve.

**Step 11.** Close the Air Supply Control Valve.

**Step 12.** Manually operate Zone 1 of the Releasing Panel, and then operate Zone 2 of the Releasing Panel by partially opening the System Main Drain Valve (Fig. 2B) to relieve air pressure at the Low Pressure Alarm Switch, and verify the following:

- That the DV-5 Deluge Valve operates, as is indicated by a discharge of water from the System Main Drain Valve
- That the Waterflow Pressure Alarm Switch (Fig. 3B) and its associated alarms properly operate
- That the Water Motor Alarm, if applicable, properly operates

**NOTE:** *This procedure simulates automatic system operation upon both electric detection and loss of system air pressure.*

**Step 13.** Reset the Double Interlock Preaction System in accordance with the System Setting Procedure section.

### Quarterly Waterflow Alarm Test Procedure

Testing of the system waterflow alarms must be performed quarterly. To test the waterflow alarm, open the Alarm Test Valve, which will allow a flow of water to the Waterflow Pressure Alarm Switch and/or Water Motor Alarm. Upon satisfactory completion of the test, close the Alarm Test Valve.

## Ordering Procedure

The DV-5 Double Interlock Praction System With Electric/Electric Actuation trim can be ordered pre-trimmed or non-assembled as separate items.

For non-assembled the following items must be ordered separately:

- DV-5 Deluge Valve
- CV-1FR Riser Check Valve
- Couplings
- Double Interlock Praction Electric/Electric Actuation Trim, Semi-Preassembled
- Supervisory Air Supply
- Accessories

**NOTE:** 1-1/2 inch (DN40) risers utilize a 2 inch (DN50) Model CV-1FR Riser Check Valve connected to the 1-1/2 inch (DN40) DV-5 Deluge Valve by a 2 x 1-1/2 inch Figure 716 Reducing Coupling.

### Replacement Trim Parts

Specify: (description) for use with DV-5 Deluge Valve, P/N (see Figure 3A)

### DV-5 Deluge Valve (Select One)

P/Ns are for American Standard Groove x Groove Connections, and Threaded Ports, For other configurations refer to Technical Data Sheet TFP1305. Specify: (size) DV-5 Groove x Groove Deluge Valve, P/N (specify):

1-1/2 Inch	P/N 52-477-1-919
2 Inch	P/N 52-477-1-910
3 Inch	P/N 52-477-1-912
4 Inch	P/N 52-477-1-913
6 Inch	P/N 52-477-1-915
8 Inch	P/N 52-477-1-916

### Riser Check Valve (Select One)

P/Ns are for American Standard Grooved Connections. For other configurations, refer to Technical Data Sheet TFP950 for the Groove x Groove Model CV-1FR Riser Check Valve. Specify: (size), Model CV-1FR Groove x Groove Riser Check Valve, P/N (specify):

2 Inch	P/N 59-590-1-020
3 Inch	P/N 59-590-1-030
4 Inch	P/N 59-590-1-040
6 Inch	P/N 59-590-1-060
8 Inch	P/N 59-590-1-080

**NOTE:** For 1-1/2 inch (DN40) risers, use the 2 inch (DN50) Riser Check Valve.

### Coupling (Select One)

P/Ns are for American Standard Grooved Connections. For other configurations and finishes, refer to Technical Data Sheet TFP1830 or TFP1880. A coupling to attach the Riser Check Valve to the outlet of the Deluge Valve must be separately ordered. Specify: (Size), (Figure #), painted, (description), P/N (specify). For 1-1/2 inch risers, order an additional Reducing Coupling for the outlet of the 2 inch Riser Check Valve.

2 x 1-1/2 Inch Figure 716 Painted Reducing Coupling	P/N 7162015ES
2 Inch Figure 772 Painted Rigid Coupling	P/N 77220ASC
3 Inch Figure 772 Painted Rigid Coupling	P/N 77230ASC
4 Inch Figure 772 Painted Rigid Coupling	P/N 77240ASC
6 Inch Figure 772 Painted Rigid Coupling	P/N 77260ASC
8 Inch Figure 772 Painted Rigid Coupling	P/N 77280ASC

### Double Interlock Praction Trim (Select One)

Specify: (specify size), (specify galvanized or black — galvanized is standard) Semi-Preassembled Double Interlock Praction System with Electric/Electric Actuation Trim for DV-5 Deluge Valves, P/N (specify):

1-1/2 & 2 Inch Galvanized	P/N 52-478-2-328
1-1/2 & 2 Inch Black	P/N 52-478-1-328
3 Inch Galvanized	P/N 52-478-2-125
3 Inch Black	P/N 52-478-1-125
4, 6 & 8 Inch Galvanized	P/N 52-478-2-322
4, 6 & 8 Inch Black	P/N 52-478-1-322

### Automatic System Air Supply (Select One)

A device capable of maintaining a nominal system air or nitrogen pressure of nominal 15 psi (1,0 bar) must be separately ordered. Specify: (Model and Description), P/N (specify):

Model AMD-1 Air Maintenance Device (TFP1221)	P/N 52-324-2-002
Model AMD-3 Nitrogen Maintenance Device (TFP1241)	P/N 52-328-2-001

### Solenoid Valve (Select One Only When Using Double Interlock Praction Trim without Model QRS Accelerator)

A Solenoid Valve compatible with the anticipated maximum water supply pressure must be ordered separately. Refer to Technical Data Sheet TFP2180 for other voltage ratings and NEMA classifications. Specify: 24 VDC, NEMA 2, 4 and 4X, (specify 175 or 250 psi) Solenoid Valve, P/N (specify):

175 psi	P/N 52-287-1-024
250 psi	P/N 52-287-1-124

### Pre-trimmed DV-5 Double Interlock - Electric/Electric Actuation Assembly with Butterfly Valve

Specify: (size), G x G End Connection, Pre-Trimmed DV-5 Assembly with Butterfly Valve, P/N (specify):

1-1/2 Inch G x G	P/N 52-918-0-1AP
2 Inch G x G	P/N 52-928-0-1AP
3 Inch G x G	P/N 52-938-0-1AP
4 Inch G x G	P/N 52-948-0-1AP
6 Inch G x G	P/N 52-968-0-1AP
8 Inch G x G	P/N 52-988-0-1AP

### Pre-trimmed DV-5 Double Interlock - Electric/Electric Actuation Assembly without Butterfly Valve

Specify: (specify size), (specify) End Connection, Pre-Trimmed DV-5 Assembly without Butterfly Valve, P/N (specify):

3 Inch F x G	P/N 52-938-2-1AP
4 Inch F x G	P/N 52-948-2-1AP
6 Inch F x G	P/N 52-968-2-1AP
8 Inch F x G	P/N 52-988-2-1AP

### Accessories (as needed)

Specify: (description), P/N (specify):

600 psi Water Pressure Gauge	P/N 92-343-1-004
Model WMA-1 Water Motor Alarm (TFP921)	P/N 52-630-1-001P

**Model QRS Electronic Accelerator**  
Please refer to Technical Data Sheet TFP1100.