

DV-5 Deluge Valve, Diaphragm Style, 1-1/2 thru 8 Inch (DN40 thru DN200), Deluge System – Electric Actuation

General Description

The DV-5 Deluge Valve (described in Technical Data Sheet TFP1305) is a diaphragm style valve that depends upon water pressure in the Diaphragm Chamber to hold the Diaphragm closed against the water supply pressure. When the DV-5 Valve is set for service, the Diaphragm Chamber is pressurized through the trim connections from the inlet side of the system's main control valve, for example an O.S.&Y. gate valve or butterfly valve (Ref. Figures 1 and 4).

Operation of an electrical device such as a heat sensitive thermostat, smoke detector, or electrical manual control station signals the Deluge Valve Releasing Panel to energize the Solenoid Valve. In turn, the energized Solenoid Valve opens to release water from the Diaphragm Chamber faster than it can be replenished through the 1/8 inch (3,2 mm) restriction provided by the Model ASV-1 Automatic Shut-Off Valve in the diaphragm supply connections (Item 5 - Fig. 3A and 5, also described in Technical Data Sheet TFP1384). This results in a rapid pressure drop in the Diaphragm Chamber and the force differential applied through the Diaphragm that holds it in the set position is reduced below the valve trip point. The water supply pressure then forces the Diaphragm open permitting water to flow into the system piping, as well as through the Alarm Port to actuate the system alarms.

As water flows into the system, the pilot chamber of the Model ASV-1 Automatic Shut-Off Valve (Item 5 - Fig. 3A and 5) becomes pressurized and the ASV-1 automatically shuts off the diaphragm chamber supply flow to the DV-5 Diaphragm Chamber. Shutting off the diaphragm chamber supply flow prevents the DV-5 Diaphragm Chamber from becoming re-pressurized, thereby preventing inadvertent closing of the DV-5 during a fire (as may be the case should the Solenoid Valve become de-energized after its initial operation).

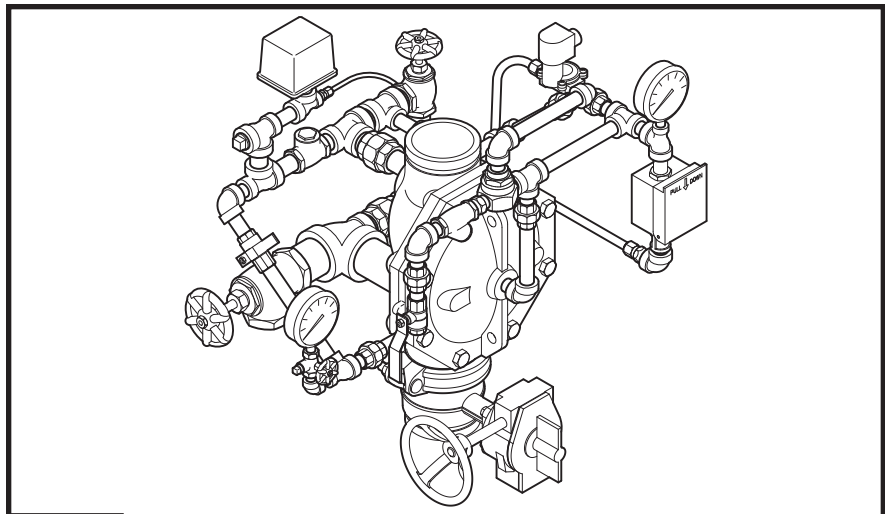

NOTICE

The DV-5 Deluge Valve with Electric Actuation Trim described herein must be installed and maintained in compliance with this document, as well as with the applicable standards of the National Fire Protection Association, in addition to the standards of any other authorities having jurisdiction. Failure to do so may impair the performance of these devices.

The owner is responsible for maintaining their fire protection system and devices in proper operating condition. Contact the installing contractor or product manufacturer with any questions.

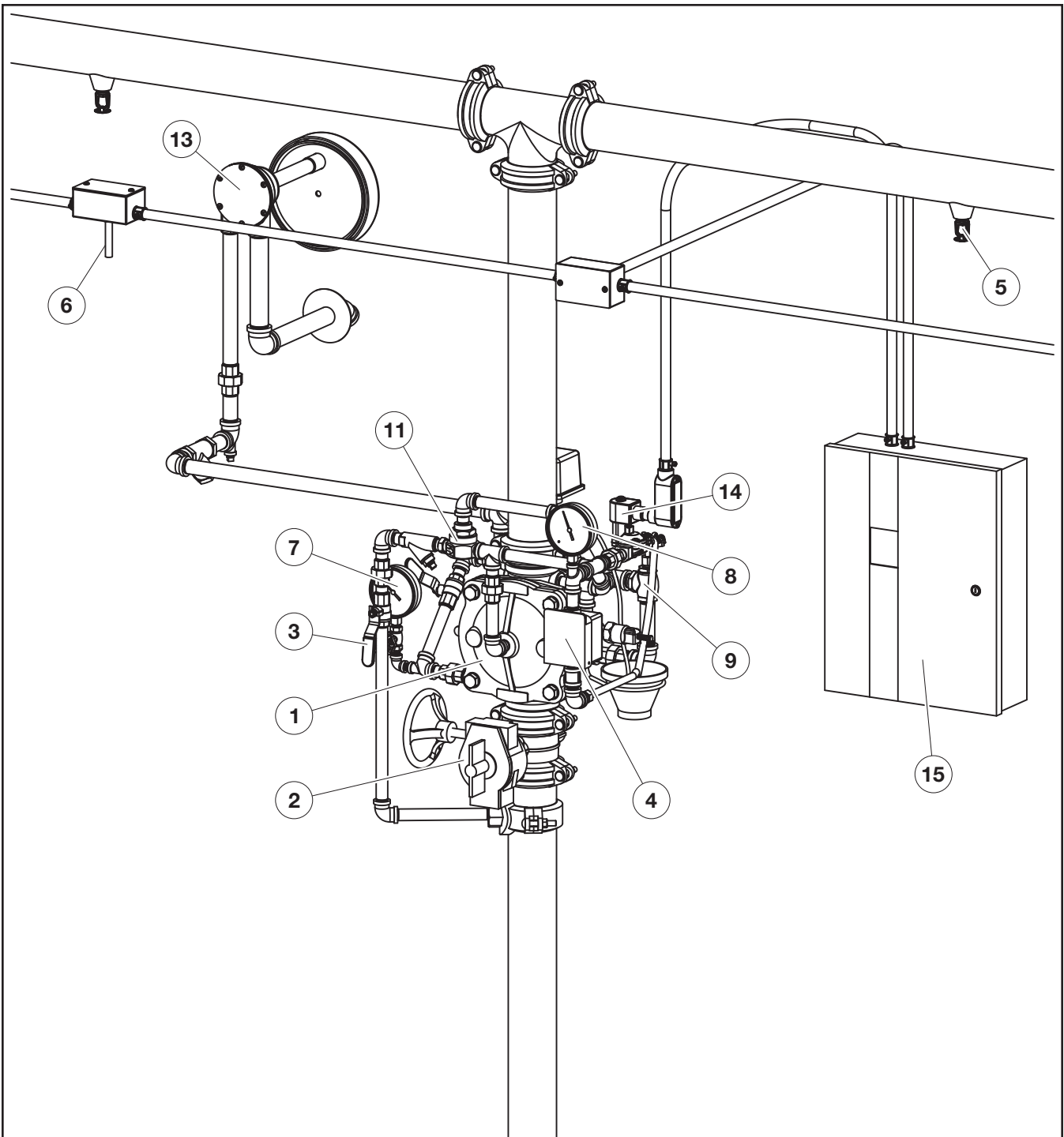

- 1 - DV-5 Deluge Valve
- 2 - Main Control Valve (N.O.)
- 3 - Diaphragm Chamber Supply Control Valve (N.O.)
- 4 - Local Manual Control Station
- 5 - Open Nozzles or Sprinklers
- 6 - Heat Detectors, Smoke Detectors, etc. (Fire Detection)

- 7 - Water Supply Pressure Gauge
- 8 - Diaphragm Chamber Pressure Gauge
- 9 - System Drain Valve (N.C.)
- 10 - Main Drain Valve (N.C.) (Shown at Rear of Valve)
- 11 - Diaphragm Chamber Automatic Shut-Off Valve

- 12 - Waterflow Pressure Alarm Switch (Shown at Rear of Valve)
- 13 - Water Motor Alarm (Optional)
- 14 - Solenoid Valve
- 15 - Deluge Valve Releasing Panel

FIGURE 1 (1 OF 2)
SYSTEM SCHEMATIC (FRONT VIEW)
ELECTRIC ACTUATION

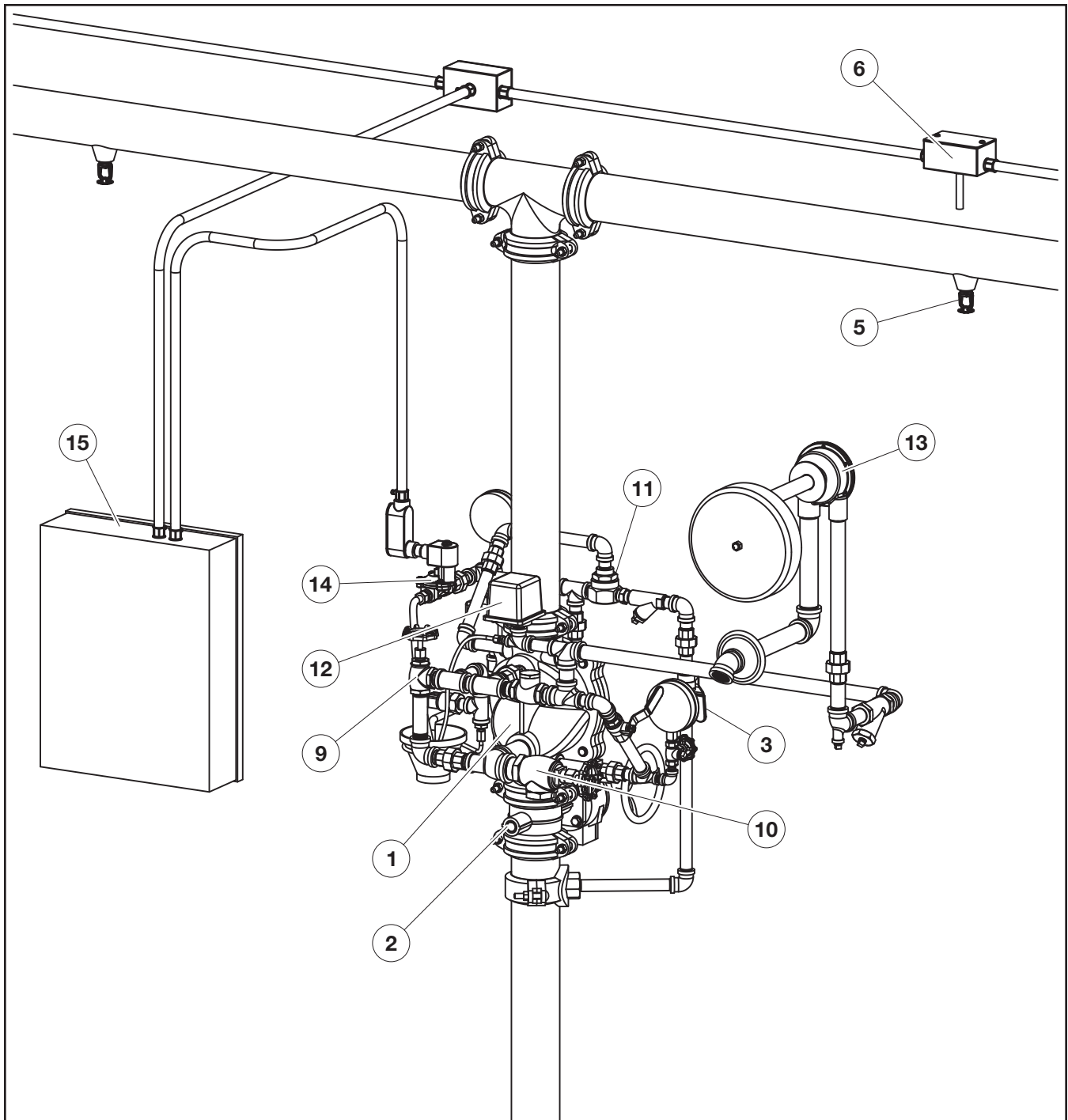

- | | | |
|------------------------------------------------------------|----------------------------------------------------------------|-----------------------------------|
| 1 - DV-5 Deluge Valve | 7 - Water Supply Pressure Gauge (Shown at Front of Valve) | 13 - Water Motor Alarm (Optional) |
| 2 - Main Control Valve (N.O.) | 8 - Diaphragm Chamber Pressure Gauge (Shown at Front of Valve) | 14 - Solenoid Valve |
| 3 - Diaphragm Chamber Supply Control Valve (N.O.) | 9 - System Drain Valve (N.C.) | 15 - Deluge Valve Releasing Panel |
| 4 - Local Manual Control Station (Shown at Front of Valve) | 10 - Main Drain Valve (N.C.) | |
| 5 - Open Nozzles or Sprinklers | 11 - Diaphragm Chamber Automatic Shut-Off Valve | |
| 6 - Heat Detectors, Smoke Detectors, etc. (Fire Detection) | 12 - Waterflow Pressure Alarm Switch | |

FIGURE 1 (2 OF 2)
SYSTEM SCHEMATIC (REAR VIEW)
ELECTRIC ACTUATION

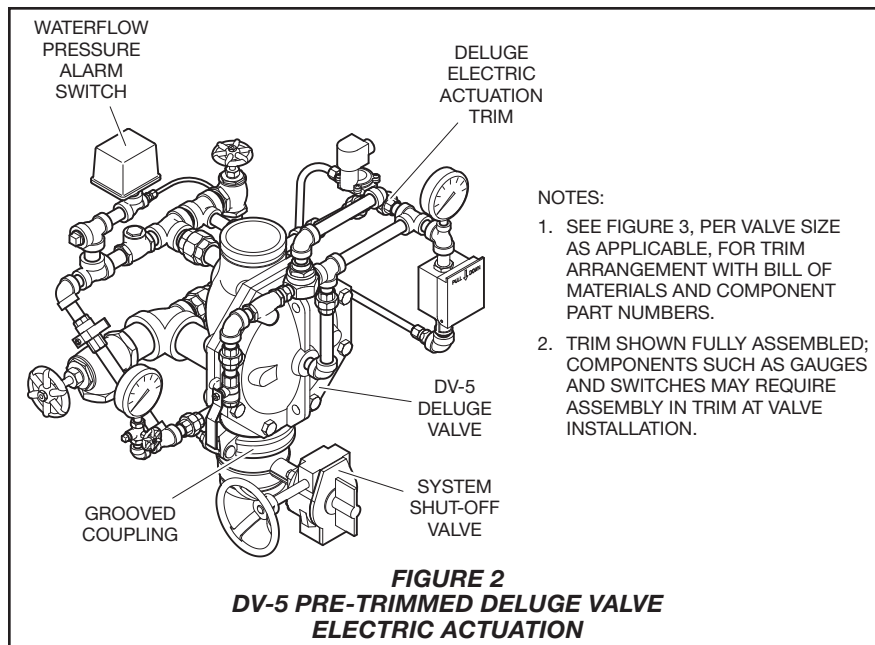

Technical Data

Approvals

UL and C-UL Listed
FM Approved.

Valve Trim

The Vertical Electric Actuation Trim (Fig. 3A/3B) and Horizontal Electric Actuation Trim (Fig. 5) form a part of the laboratory listings and approvals for the DV-5 Valve and are necessary for its proper operation.

Each package of trim includes the following items:

- Water Supply Pressure Gauge
- Diaphragm Chamber Pressure Gauge
- Diaphragm Chamber Connections
- Manual Control Station
- Main Drain Valve
- System Drain Valve
- Alarm Test Valve
- Automatic Drain Valve

The following items are included in the Pre-trimmed Valve Assembly and can be ordered separately for the valve trim:

- Model BFV-N Butterfly Valve
- Waterflow Pressure Alarm Switch (PS10-2)
- Figure 577 Grooved Coupling

To ease field assembly of the trim arrangement, the vertical trim components are provided partially assembled as shown in Figure 3B.

The trim arrangement is provided with galvanized, black, or brass nipples and fittings. The galvanized and brass trim are intended for non-corrosive or corrosive conditions, whereas the black trim is principally intended for use with AFFF systems.

NOTE: When the system pressure is greater than 175 psi (12,1 bar), provision is to be made to replace the standard order 300 psi (20,7 bar) Water Pressure Gauges, shown in Figure 3A/3B and 5 with separately ordered 600 psi (41,4 bar) Water Pressure Gauges.

The Electric Actuation Trim is required for electric operation of the DV-5 Valve by a detection system consisting of electrical devices such as heat sensitive thermostats, smoke detectors, and/or electric manual pull stations. Information on the various types of separately ordered Solenoid Valves that may be used with this trim package is given in Technical Data Sheet TFP2180. Nominal installation dimensions for the Vertical Electric Actuation Trim are shown in Figure 4.

NOTE: Approval by Factory Mutual is contingent on the use of an FM Approved 24VDC Solenoid Valve. FM only approves solenoid valves for use in non-hazardous locations.

Consult with the authority having jurisdiction regarding installation criteria pertaining to electric actuation circuitry.

The Electric Actuation Trim is provided with a Model ASV-1 Automatic Shut-Off Valve (Item 5 - Fig. 3A and 5); consequently, the release circuit of the Releasing Panel need only provide the standard ten minutes of alarm condi-

tion intended to energize the Solenoid Valve to open. After the ten minute duration, at which point should the Solenoid Valve become de-energized and close (especially while operating under battery back-up), the Automatic Shut-Off Valve will have already automatically closed, thereby preventing the DV-5 Diaphragm Chamber from becoming re-pressurized, and preventing an inadvertent closing of the DV-5 during a fire event.

Materials of Construction

NOTES: The galvanized or brass nipples and fittings for the Valve Trim provide corrosion resistance and are intended to extend the life of the installation of the DV-5 Valve when exposed to internal and external corrosive conditions. Although these selections are intended to resist corrosion, it is recommended that the end user or other technical expert familiar with conditions at the proposed installation be consulted with respect to these selections for a given corrosive condition.

Systems using a seawater or brackish water supply require special considerations in order to extend the life of the valve and trim. This type of system ideally should be configured with a primary source of clean fresh water (e.g., a pressurized water tank) and that only upon system operation is the secondary water supply (seawater or brackish water) allowed to enter the system. After the system operation, the system should be thoroughly flushed with clean fresh water. Following this recommendation will increase the service life of the DV-5 Valve and Valve Trim.

Pressure Gauges. Bronze bourdon tube with brass socket.

Gauge Test Valve. Bronze body per ASTM B584.

Manual Control Station. Corrosion resistant copper alloys and glass filled PTFE seals. Thermoplastic enclosure.

Automatic Drain Valve. Brass body per ASTM B584, Type 440 stainless steel or brass per ASTM B134 Ball, and galvanized steel inlet.

Automatic Shut-Off Valve. Brass body, cover, and center seat per UNS C36000, Type 316 stainless steel spring, and Nylon fabric reinforced, natural rubber diaphragm per ASTM D2000.

Ball Valve. Corrosion resistant copper alloys and glass filled PTFE seals.

Spring Loaded Check Valve. Brass body and buna-n seal.

NO.	DESCRIPTION	QTY.	P/N
1	300 psi/ 2000 kPa Water Pressure Gauge	2	92-343-1-005
2	1/4" Gauge Test Valve	1	46-005-1-002
3	Model MC-1 Manual Control Station	1	52-289-2-001
4	Model AD-1 Automatic Drain Valve	1	52-793-2-004
5	Model ASV-1 Automatic Shut-Off Valve	1	92-343-1-021
6	Item No. Not Used		
7	1/2" Ball Valve	2	46-050-1-004
8	1/2" Spring Loaded Check Valve	1	92-322-1-002
9	1/2" Y-Strainer	1	52-353-1-005
10	3/4" Swing Check Valve	1	46-049-1-005
11	3/4" Angle Valve	2	46-048-1-005
12	Drip Funnel Connector	1	92-211-1-005
13	Drip Funnel Bracket	1	92-211-1-003
14	Drip Funnel	1	92-343-1-007
15	3/32" Vent Fitting	1	92-032-1-002
16	1/4" x 18" Tubing	1	CH
17	1/2" Tubing Connector	1	CH
18	1/2" x 12" Tubing	1	CH
19	1/4" Plug	1	CH
20	3/4" Plug	1	CH
21	1/2" Union	5	CH

NO.	DESCRIPTION	QTY.	P/N
22	3/4" Union	2	CH
23	1/4" 90° Elbow	1	CH
24	1/2" 90° Elbow	8	CH
25	3/4" 90° Elbow	1	CH
26	1/2" Tee	3	CH
27	1/2" x 1/4" x 1/2" Tee	3	CH
28	3/4" Tee	2	CH
29	3/4" x 1/2" x 3/4" Tee	2	CH
30	3/4" x 3/4" x 1/2" Tee	1	CH
31	1/4" x Close Nipple	2	CH
32	1/2" x Close Nipple	3	CH
33	1/2" x 1-1/2" Nipple	10	CH
34	1/2" x 2" Nipple	1	CH
35	1/2" x 2-1/2" Nipple	4	CH
36	1/2" x 5" Nipple	2	CH
37	1/2" x 7" Nipple	1	CH
38	Select Nipple per Table	1	CH
39	Select Nipple per Table	1	CH
40	Select Nipple per Table	1	CH
41	3/4" x Close Nipple	1	CH
42	3/4" x 1-1/2" Nipple	8	CH

NO.	DESCRIPTION	QTY.	P/N
43	3/4" x 2" Nipple	1	CH
44	3/4" x 4" Nipple	1	CH
45	Select Nipple per Table	1	CH
E1	Solenoid Valve Ordered Separately Per Data Sheet TFP2180	1	Refer to Data Sheet
E2	1/2" Tubing Connector	1	CH
E3	1/2" x 24" Tubing	1	CH
E4	1/2" x 1-1/2" Nipple	1	CH
COMPONENTS INCLUDED ONLY IN PRE-TRIMMED VALVE ASSEMBLIES:			
A1	Waterflow Pressure Alarm Switch, Model PS10-2	1	25710
A2	Butterfly Valve, Power Ball 300: 1-1/2" (DN40)	1	51024A
	2" (DN50)	1	51021A
A3	Figure 577 Coupling: 1-1/2" (DN40)	1	57715ACP
	2" (DN50)	1	57720ACP

Nipple Number	Select Appropriate Nipple Sizes per DV-5 Deluge Valve Size	
	1-1/2" (DN40)	2" (DN50)
38	1/2" x 1-1/2"	1/2" x 2"
39	1/2" x 2"	1/2" x 1-1/2"
40	1/2" x 5"	1/2" x 5-1/2"
45	3/4" x 1-1/2"	3/4" x 2-1/2"

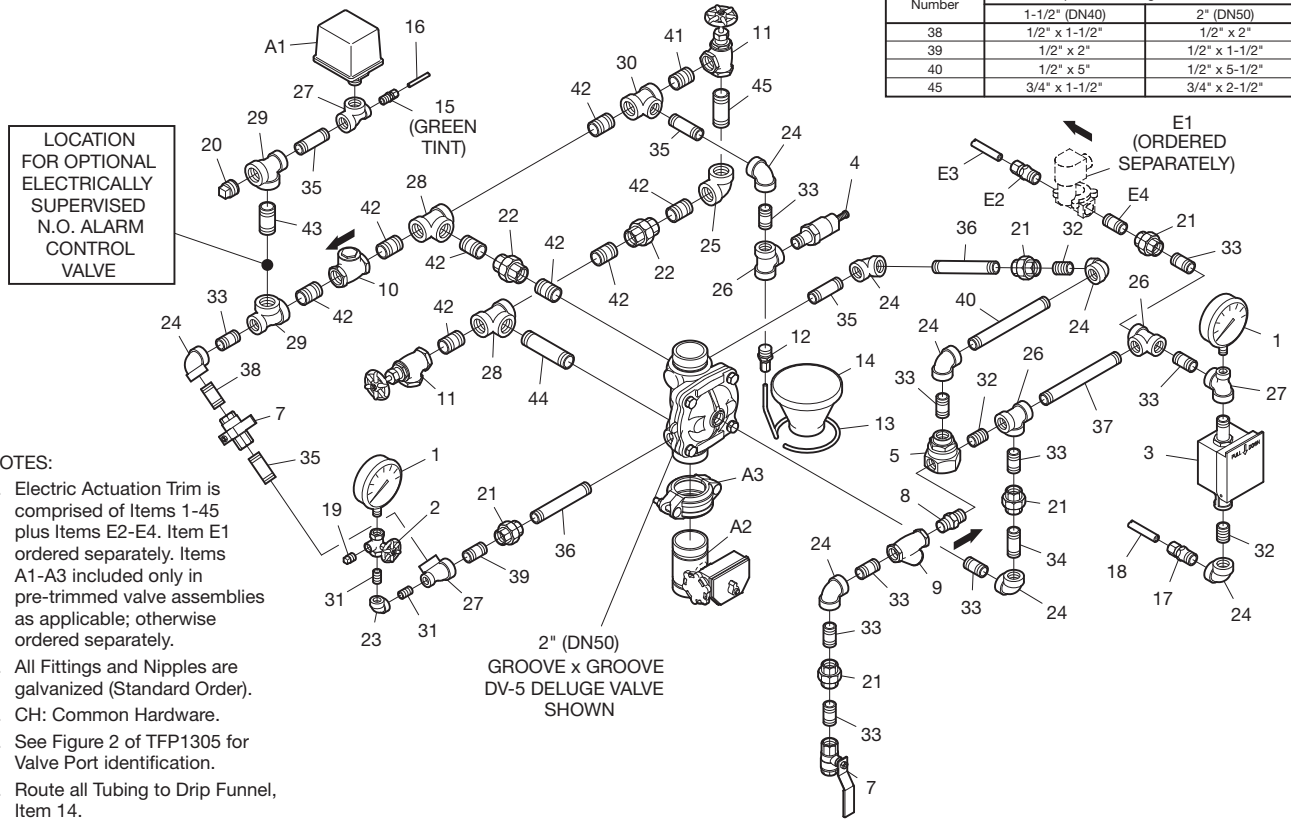

- NOTES:
1. Electric Actuation Trim is comprised of Items 1-45 plus Items E2-E4. Item E1 ordered separately. Items A1-A3 included only in pre-trimmed valve assemblies as applicable; otherwise ordered separately.
 2. All Fittings and Nipples are galvanized (Standard Order).
 3. CH: Common Hardware.
 4. See Figure 2 of TFP1305 for Valve Port identification.
 5. Route all Tubing to Drip Funnel, Item 14.

FIGURE 3A (1 OF 3)
1-1/2 AND 2 INCH (DN40 AND DN50) DV-5 DELUGE VALVES
EXPLODED VIEW OF VERTICAL ELECTRIC ACTUATION TRIM

Y-Strainer. Bronze body per ASTM B584 and Type 304 stainless steel screen.

Swing Check Valve. Bronze body per ASTM B584 and buna-n seal.

Angle Valve. Bronze body per ASTM B584 and nitrile disc (TEFLON disc for 2 inch size valve).

3/32" Vent Fitting. Brass per ASTM B16.

Tubing Connector. Brass per ASTM B16.

Tubing. Type L copper per ASTM B88.

Pipe Fittings. Galvanized malleable iron per ANSI B16.3 or cast iron per ANSI B16.4; black malleable iron per ANSI B16.3 or cast iron per ANSI B16.4; or, bronze per ANSI B16.15.

Pipe Nipples. Schedule 40 galvanized steel per ASTM A53 or A135; Schedule 40 black steel per ASTM A53 or A135; or, Schedule 40 red brass pipe per ASTM B43.

NO.	DESCRIPTION	QTY.	P/N
1	300 psi/ 2000 kPa Water Pressure Gauge	2	92-343-1-005
2	1/4" Gauge Test Valve	1	46-005-1-002
3	Model MC-1 Manual Control Station	1	52-289-2-001
4	Model AD-1 Automatic Drain Valve	1	52-793-2-004
5	Model ASV-1 Automatic Shut-Off Valve	1	92-343-1-021
6	Item No. Not Used		
7	1/2" Ball Valve	2	46-050-1-004
8	1/2" Spring Loaded Check Valve	1	92-322-1-002
9	1/2" Y-Strainer	1	52-353-1-005
10	3/4" Swing Check Valve	1	46-049-1-005
11	3/4" Angle Valve	1	46-048-1-005
12	1-1/4" Angle Valve	1	46-048-1-007
13	Drip Funnel Connector	1	92-211-1-005
14	Drip Funnel Bracket	1	92-211-1-003
15	Drip Funnel	1	92-343-1-007
16	3/32" Vent Fitting	1	92-032-1-002
17	1/4" x 18" Tubing	1	CH
18	1/2" Tubing Connector	1	CH

NO.	DESCRIPTION	QTY.	P/N
19	1/2" x 12" Tubing	1	CH
20	1/4" Plug	1	CH
21	3/4" Plug	1	CH
22	1/2" Union	5	CH
23	3/4" Union	2	CH
24	1/4" 90° Elbow	1	CH
25	1/2" 90° Elbow	8	CH
26	3/4" 90° Elbow	1	CH
27	1/2" Tee	3	CH
28	1/2" x 1/4" x 1/2" Tee	3	CH
29	3/4" Tee	1	CH
30	3/4" x 1/2" x 3/4" Tee	2	CH
31	3/4" x 3/4" x 1/2" Tee	1	CH
32	1-1/4" x 3/4" x 1-1/4" Tee	1	CH
33	1/4" x Close Nipple	2	CH
34	1/2" x Close Nipple	2	CH
35	1/2" x 1-1/2" Nipple	13	CH
36	1/2" x 2-1/2" Nipple	2	CH

NO.	DESCRIPTION	QTY.	P/N
37	1/2" x 3-1/2" Nipple	1	CH
38	1/2" x 4" Nipple	1	CH
39	1/2" x 4-1/2" Nipple	1	CH
40	1/2" x 5" Nipple	1	CH
41	1/2" x 5-1/2" Nipple	1	CH
42	1/2" x 7" Nipple	2	CH
43	3/4" x Close Nipple	3	CH
44	3/4" x 1-1/2" Nipple	5	CH
45	3/4" x 2" Nipple	1	CH
46	3/4" x 4-1/2" Nipple	1	CH
47	1-1/4" x 2" Nipple	1	CH
48	1-1/4" x 4" Nipple	1	CH
E1	Solenoid Valve Ordered Separately		Refer to
	Per Data Sheet TFP2180	1	Data Sheet
E2	1/2" Tubing Connector	1	CH
E3	1/2" x 24" Tubing	1	CH
E4	1/2" x 1-1/2" Nipple	1	CH

COMPONENTS INCLUDED ONLY IN PRE-TRIMMED VALVE ASSEMBLIES:

A1	Waterflow Pressure Alarm Switch, Model PS10-2.	1	25710
A2	Model BFV-N Butterfly Valve, 3" (DN80)	1	59300F030N
A3	Figure 577 Coupling, 3" (DN80)	1	57730ACP

LOCATION FOR OPTIONAL ELECTRICALLY SUPERVISED N.O. ALARM CONTROL VALVE

NOTES:

1. Electric Actuation Trim is comprised of Items 1-48 plus Items E2-E4. Item E1 ordered separately. Items A1-A3 included only in pre-trimmed valve assemblies as applicable; otherwise ordered separately.
2. All Fittings and Nipples are galvanized (Standard Order).
3. CH: Common Hardware.
4. See Figure 2 of TFP1305 for Valve Port identification.
5. Route all Tubing to Drip Funnel, Item 15.

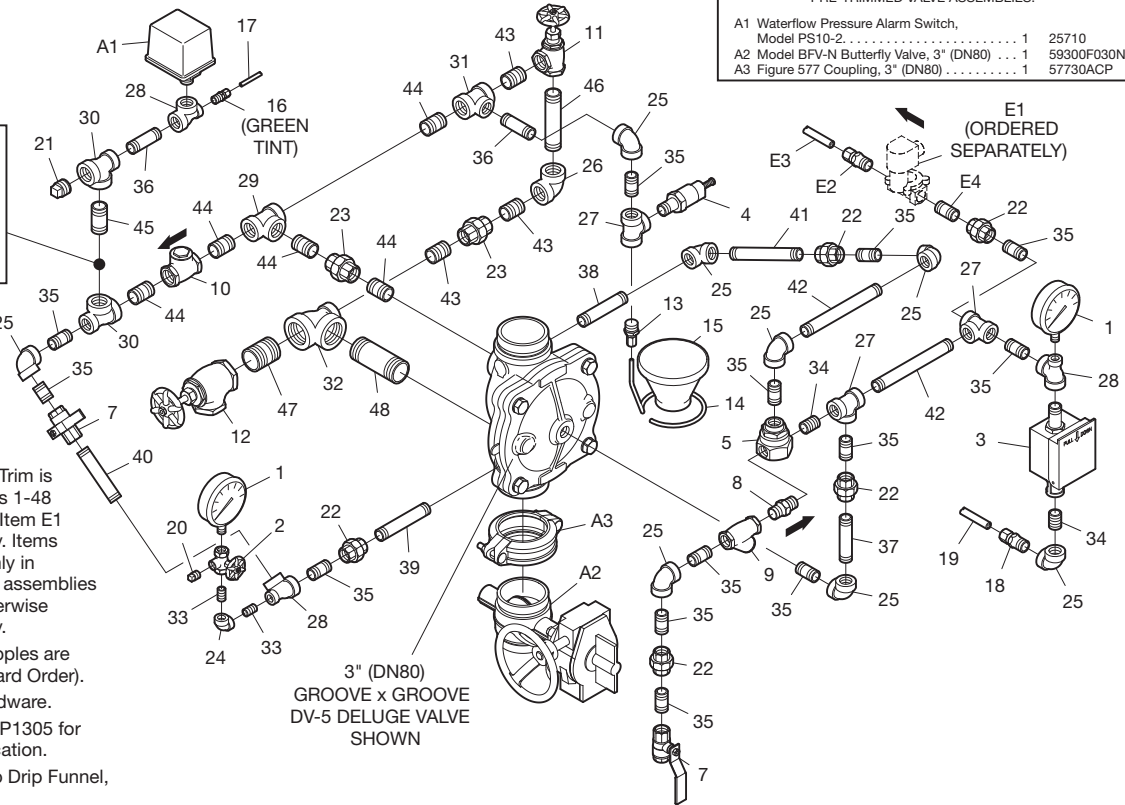

FIGURE 3A (2 OF 3)
3 INCH (DN80) DV-5 DELUGE VALVE
EXPLODED VIEW OF VERTICAL ELECTRIC ACTUATION TRIM

NO.	DESCRIPTION	QTY.	P/N
1	300 psi/ 2000 kPa Water Pressure Gauge	2	92-343-1-005
2	1/4" Gauge Test Valve	1	46-005-1-002
3	Model MC-1 Manual Control Station	1	52-289-2-001
4	Model AD-1 Automatic Drain Valve	1	52-793-2-004
5	Model ASV-1 Automatic Shut-Off Valve	1	92-343-1-021
6	Item No. Not Used		
7	1/2" Ball Valve	2	46-050-1-004
8	1/2" Spring Loaded Check Valve	1	92-322-1-002
9	1/2" Y-Strainer	1	52-353-1-005
10	3/4" Swing Check Valve	1	46-049-1-005
11	1" Angle Valve	1	46-048-1-006
12	2" Angle Valve	1	46-048-1-009
13	Drip Funnel Connector	1	92-211-1-005
14	Drip Funnel Bracket	1	92-211-1-003
15	Drip Funnel	1	92-343-1-007
16	3/32" Vent Fitting	1	92-032-1-002
17	Select Tubing per Table	1	CH
18	1/2" Tubing Connector	1	CH
19	1/2" x 24" Tubing	1	CH
20	1/4" Plug	1	CH
21	3/4" Plug	1	CH
22	1/2" Union	5	CH
23	1" Union	2	CH
24	1/4" 90° Elbow	1	CH
25	1/2" 90° Elbow	8	CH
26	1" 90° Elbow	1	CH
27	1/2" Tee	3	CH
28	1/2" x 1/4" x 1/2" Tee	3	CH
29	3/4" x 1/2" x 3/4" Tee	2	CH

NO.	DESCRIPTION	QTY.	P/N
30	1" x 1" x 1/2" Tee	1	CH
31	1" x 3/4" x 1" Tee	1	CH
32	2" x 1" x 2" Tee	1	CH
33	1/4" x Close Nipple	2	CH
34	1/2" x Close Nipple	2	CH
35	1/2" x 1-1/2" Nipple	10	CH
36	1/2" x 2-1/2" Nipple	3	CH
37	Select Nipple per Table	1	CH
38	1/2" x 5" Nipple	2	CH
39	1/2" x 6" Nipple	1	CH
40	1/2" x 7" Nipple	2	CH
41	Select Nipple per Table	1	CH
42	Select Nipple per Table	1	CH
43	Select Nipple per Table	1	CH
44	3/4" x 1-1/2" Nipple	1	CH
45	3/4" x 2" Nipple	1	CH
46	Select Nipple per Table	1	CH
47	1" x Close Nipple	5	CH
48	1" x 3" Nipple	1	CH
49	Select Nipple per Table	1	CH
50	2" x 3" Nipple	1	CH
51	2" x 5" Nipple	1	CH
52	Select Nipple per Table	1	CH

COMPONENTS INCLUDED ONLY IN PRE-TRIMMED VALVE ASSEMBLIES:		
NO.	DESCRIPTION	QTY. P/N
A1	Waterflow Pressure Alarm Switch, Model PS10-2	1 25710
A2	Model BFV-N Butterfly Valve:	
	4" (DN100)	1 59300F040N
	6" (DN150)	1 59300F060N
	8" (DN200)	1 59300F080N
A3	Figure 577 Coupling:	
	4" (DN100)	1 57740ACP
	6" (DN150)	1 57760ACP
	8" (DN200)	1 57780ACP

Tube No.	Select Appropriate Tube Size per DV-5 Deluge Valve Size		
	4" (DN100)	6" (DN150)	8" (DN200)
17	1/4" x 24"	1/4" x 24"	1/4" x 32"

Nipple No.	Select Appropriate Nipple Sizes per DV-5 Deluge Valve Size		
	4" (DN100)	6" (DN150)	8" (DN200)
37	1/2" x 3"	1/2" x 3"	1/2" x 5"
41	1/2" x 2-1/2"	1/2" x 5-1/2"	1/2" x 8-1/2"
42	1/2" x 2"	1/2" x 3"	1/2" x 3-1/2"
43	1/2" x 6-1/2"	1/2" x 7-1/2"	1/2" x 9"
46	3/4" x 2-1/2"	3/4" x 3-1/2"	3/4" x 4-1/2"
49	1" x 6"	1" x 9"	1" x 12"
52	1/2" x 7"	1/2" x 7"	1/2" x 9"

LOCATION FOR OPTIONAL ELECTRICALLY SUPERVISED N.O. ALARM CONTROL VALVE

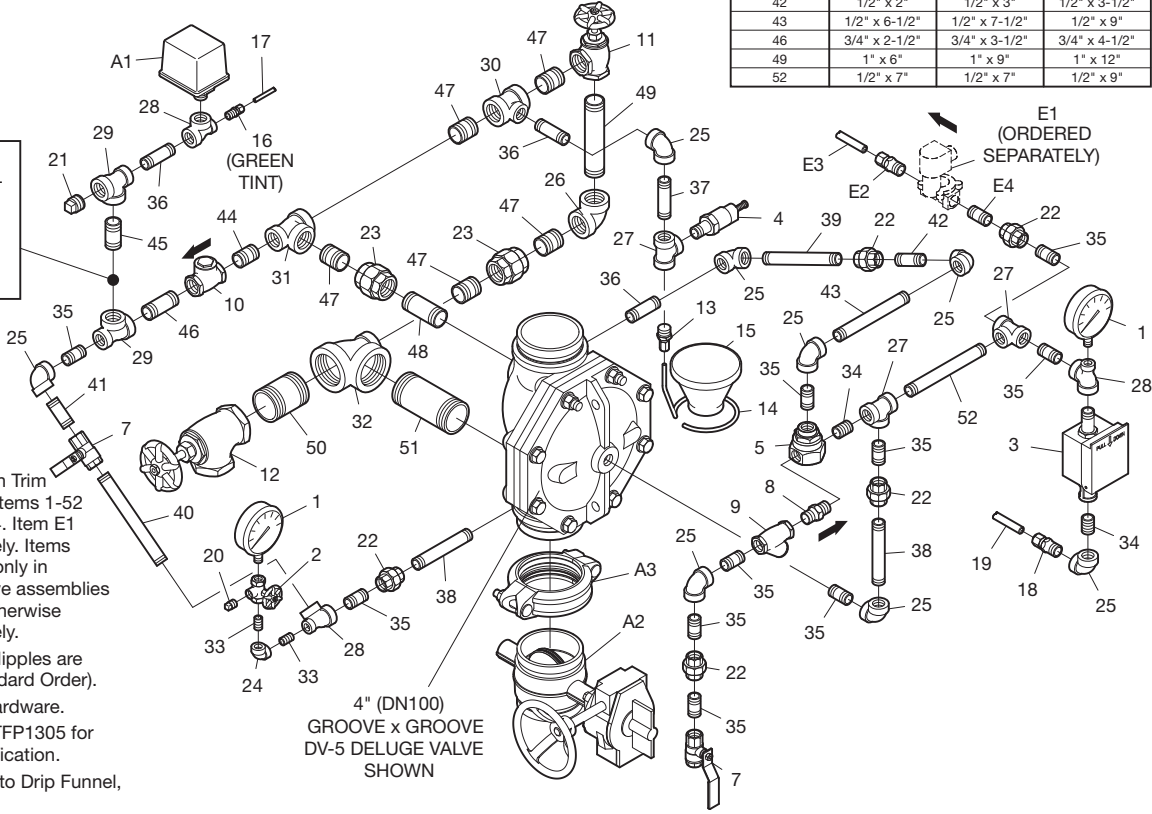

- NOTES:
1. Electric Actuation Trim is comprised of Items 1-52 plus Items E2-E4. Item E1 ordered separately. Items A1-A3 included only in pre-trimmed valve assemblies as applicable; otherwise ordered separately.
 2. All Fittings and Nipples are galvanized (Standard Order).
 3. CH: Common Hardware.
 4. See Figure 2 of TFP1305 for Valve Port identification.
 5. Route all Tubing to Drip Funnel, Item 15.

FIGURE 3A (3 OF 3)
4, 6, AND 8 INCH (DN100, DN150 AND DN200) DV-5 DELUGE VALVES
EXPLODED VIEW OF VERTICAL ELECTRIC ACTUATION TRIM

Nipple Number	Select Appropriate Nipple and Tube Sizes per DV-5 Deluge Valve Size					
	1-1/2" (DN40)	2" (DN50)	3" (DN80)	4" (DN100)	6" (DN150)	8" (DN200)
1	1/2" x Close	1/2" x 2"	1/2" x 1-1/2"	1/2" x 2-1/2"	1/2" x 5-1/2"	1/2" x 8-1/2"
2	1/2" x Close	1/2" x Close	1/2" x 1-1/2"	1/2" x 2"	1/2" x 3"	1/2" x 3-1/2"
3	1/2" x 5"	1/2" x 5-1/2"	1/2" x 7"	1/2" x 6-1/2"	1/2" x 7-1/2"	1/2" x 9"
4	3/4" x 1-1/2"	3/4" x 1-1/2"	3/4" x 1-1/2"	3/4" x 2-1/2"	3/4" x 3-1/2"	3/4" x 4-1/2"
5	3/4" x 1-1/2"	3/4" x 2-1/2"	3/4" x 4-1/2"	1" x 6"	1" x 9"	1" x 12"
6	1/2" x 1-1/2"	1/2" x 1-1/2"	1/2" x 1-1/2"	1/2" x 3"	1/2" x 3"	1/2" x 5"
7	1/2" x 7"	1/2" x 7"	1/2" x 7"	1/2" x 7"	1/2" x 7"	1/2" x 9"
Main Drain Size	3/4" NPT	3/4" NPT	1-1/4" NPT	2" NPT	2" NPT	2" NPT
Tube 1	1/4" x 18"	1/4" x 18"	1/4" x 18"	1/4" x 24"	1/4" x 24"	1/4" x 32"

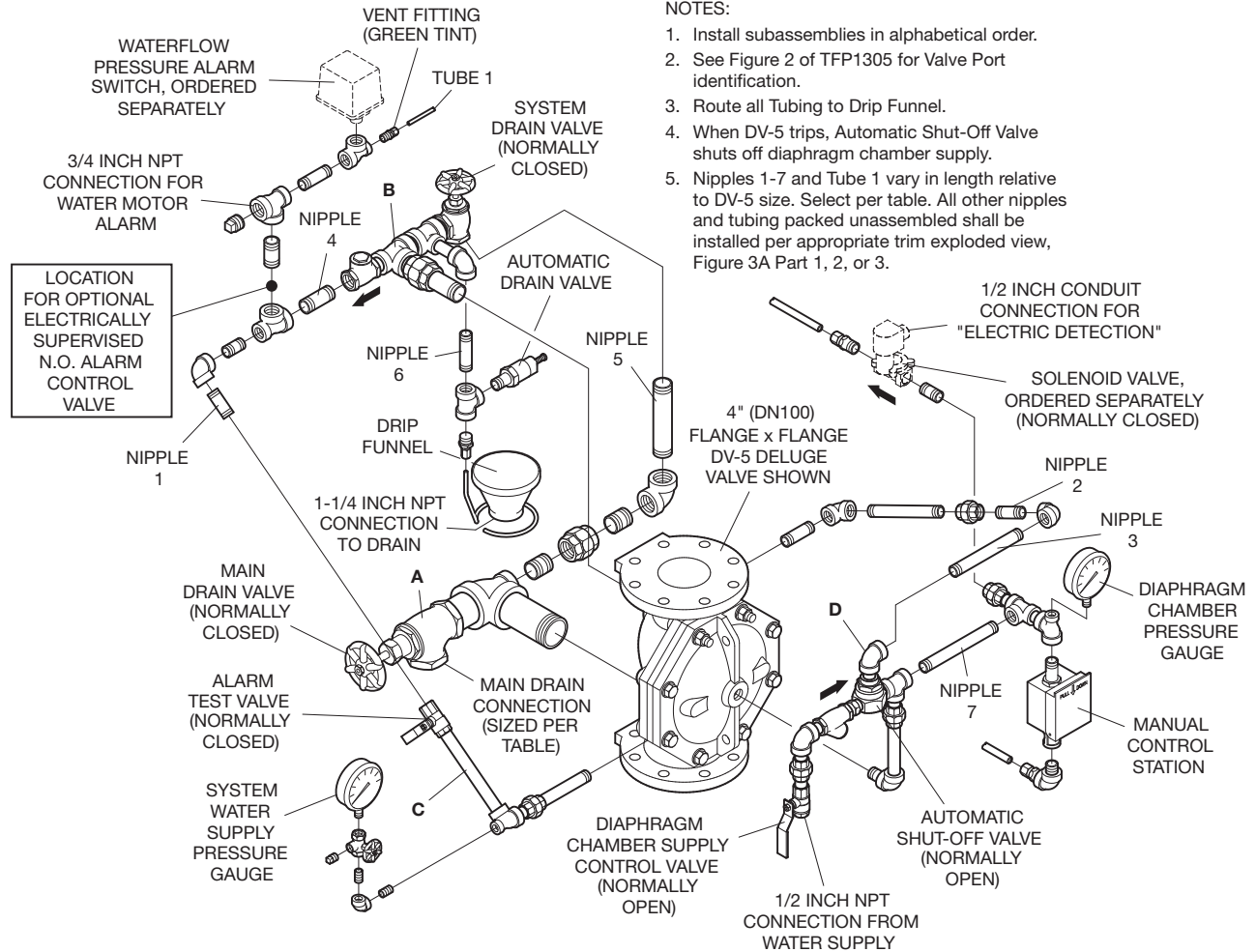

NOTES:

1. Install subassemblies in alphabetical order.
2. See Figure 2 of TFP1305 for Valve Port identification.
3. Route all Tubing to Drip Funnel.
4. When DV-5 trips, Automatic Shut-Off Valve shuts off diaphragm chamber supply.
5. Nipples 1-7 and Tube 1 vary in length relative to DV-5 size. Select per table. All other nipples and tubing packed unassembled shall be installed per appropriate trim exploded view, Figure 3A Part 1, 2, or 3.

FIGURE 3B
1-1/2 THRU 8 INCH (DN40 THRU DN200) DV-5 DELUGE VALVES
OPERATIONAL COMPONENTS OF VERTICAL ELECTRIC ACTUATION TRIM
EXPLODED ARRANGEMENT OF SEMI-PREASSEMBLED TRIM

Valve Size	Nominal Installation Dimensions in Inches and (mm)												
	A	B	C	D	E	F	G	H	J	K	L	M	N
1-1/2" DN40	7.00 (177,8)	8.88 (225,4)	13.19 (335,0)	10.50 (266,7)	15.25 (387,4)	1.25 (31,8)	5.81 (147,6)	1.81 (46,0)	3.00 (76,2)	7.00 (177,8)	3.88 (98,4)	8.00 (204,0)	4.02 (102,1)
2" DN50	7.13 (181,0)	9.13 (231,8)	13.19 (335,0)	10.50 (266,7)	15.56 (395,3)	0.94 (23,8)	6.00 (152,4)	2.00 (50,8)	3.00 (76,2)	7.00 (177,8)	3.00 (76,2)	8.63 (220,0)	4.09 (103,9)
3" DN80	7.81 (198,4)	10.44 (265,1)	13.19 (335,0)	10.50 (266,7)	19.13 (485,8)	1.63 (41,3)	6.69 (170,0)	2.69 (68,3)	4.25 (108,0)	7.00 (177,8)	0.88 (22,2)	12.75 (324,0)	3.85 (98,0)
4" DN100	10.00 (254,0)	11.75 (298,5)	14.31 (363,5)	10.50 (266,7)	22.13 (562,0)	1.75 (44,5)	8.56 (217,5)	4.44 (112,7)	6.25 (158,8)	7.13 (181,0)	0.63 (15,9)	15.75 (400,0)	4.56 (116,0)
6" DN150	11.38 (289,0)	14.31 (363,5)	15.31 (388,9)	10.50 (266,7)	23.31 (592,1)	3.50 (88,9)	9.94 (252,4)	5.81 (147,6)	6.25 (158,8)	7.13 (181,0)	1.81 (46,0)	18.13 (460,4)	5.86 (149,0)
8" DN200	12.00 (304,8)	16.00 (406,4)	16.25 (412,8)	10.50 (266,7)	25.50 (647,7)	1.75 (44,5)	10.75 (273,1)	6.50 (165,1)	6.25 (158,8)	7.13 (181,0)	7.38 (187,3)	22.50 (570,0)	5.26 (134,0)

* MINIMUM CLEARANCE

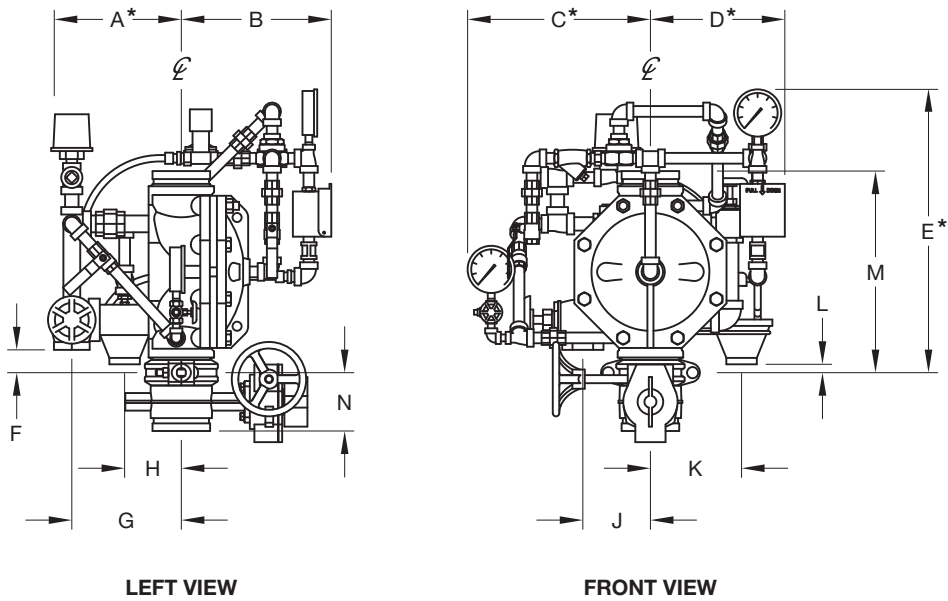

FIGURE 4
1-1/2 THRU 8 INCH (DN40 THRU DN200) DV-5 DELUGE VALVES
VERTICAL ELECTRIC ACTUATION / NOMINAL INSTALLATION DIMENSIONS

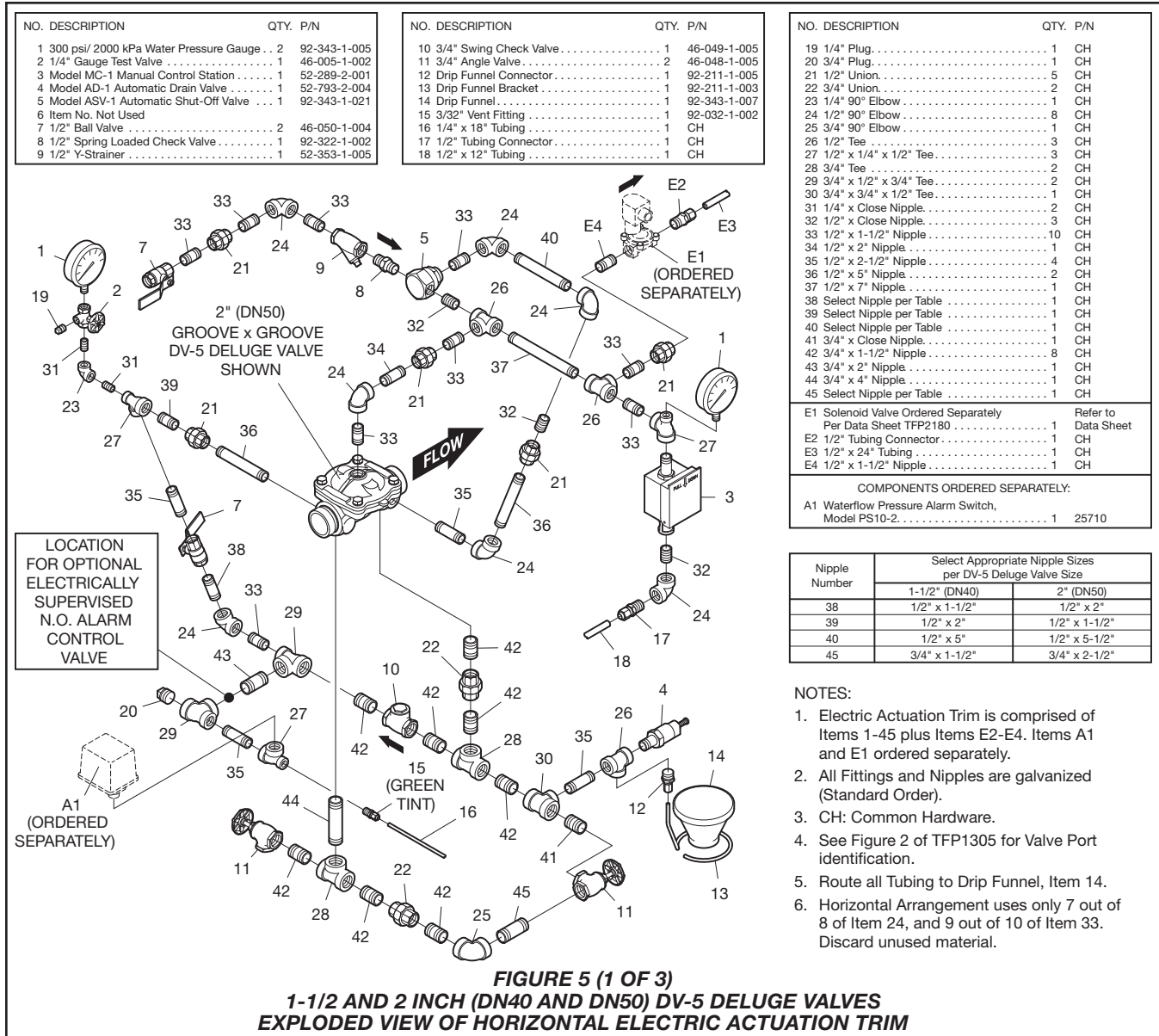

FIGURE 5 (1 OF 3)
1-1/2 AND 2 INCH (DN40 AND DN50) DV-5 DELUGE VALVES
EXPLODED VIEW OF HORIZONTAL ELECTRIC ACTUATION TRIM

Installation

General Instructions

Proper operation of the DV-5 Deluge Valves depends upon their trim being installed in accordance with the instructions given in this Technical Data Sheet. Failure to follow the appropriate trim diagram may prevent the DV-5 Valve from functioning properly, as well as void listings, approvals, and the manufacturer's warranties.

The DV-5 Valve must be installed in a readily visible and accessible location.

The DV-5 Valve, associated trim, and wet pilot lines must be maintained at a minimum temperature of 40°F (4°C).

Heat tracing of the DV-5 Valve or its associated trim is not permitted. Heat tracing can result in the formation of hardened mineral deposits that are capable of preventing proper operation.

The DV-5 Deluge Valve is to be installed in accordance with the following criteria:

Step 1. All nipples, fittings, and devices must be clean and free of scale and burrs before installation. Use pipe thread sealant sparingly on male pipe threads only.

Step 2. The DV-5 Valve must be trimmed in accordance with Figure 3A/3B or 5.

Step 3. Care must be taken to ensure that check valves, strainers, globe valves, etc. are installed with the flow arrows in the proper direction.

Step 4. Drain tubing to the Drip Funnel must be installed with smooth bends that will not restrict flow.

Step 5. The main drain and Drip Funnel drain may be interconnected provided a check valve is located at least 12 inches (300 mm) below the Drip Funnel.

Step 6. Suitable provision must be made for disposal of drain water. Drainage water must be directed such that it will not cause accidental damage to property or danger to persons.

Step 7. Connect the Diaphragm Chamber Supply Control Valve to the inlet side of the system's Main Control Valve in order to facilitate setting of the DV-5 Valve (Ref. Figure 4).

Step 8. Unused pressure alarm switch connections must be plugged.

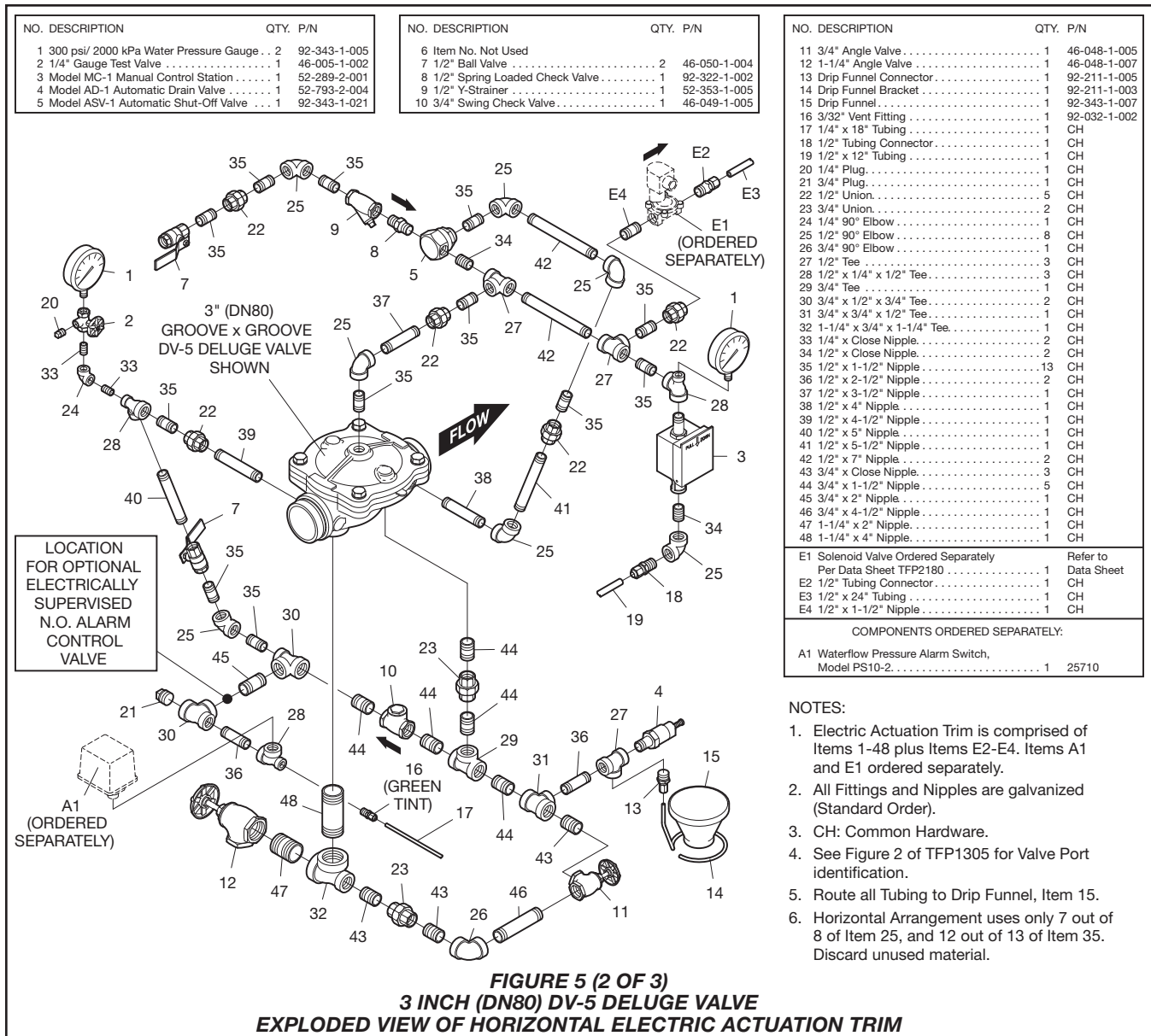

FIGURE 5 (2 OF 3)
3 INCH (DN80) DV-5 DELUGE VALVE
EXPLODED VIEW OF HORIZONTAL ELECTRIC ACTUATION TRIM

Step 9. Conduit and electrical connections are to be made in accordance with the requirements of the authority having jurisdiction and/or the National Electric Code.

Step 10. Before a system hydrostatic test is performed in accordance with NFPA 13 system acceptance test requirements, the DV-5 Diaphragm Chamber is to be depressurized, the Automatic Drain Valve (Item 4, Fig. 3A and 5) is to be temporarily replaced with a 1/2 inch NPT plug, the 3/32 inch Vent Fitting (Item 16 - Fig. 3A and 5) is to be temporarily replaced with a 1/4 inch NPT plug, and the Diaphragm Cover Bolts must be uniformly and securely tightened using a cross-draw sequence. After tightening, double-check to make certain that all of the Diaphragm Cover Bolts are securely tightened.

NO. DESCRIPTION	QTY.	P/N
1 300 psi/ 2000 kPa Water Pressure Gauge	2	92-343-1-005
2 1/4" Gauge Test Valve	1	46-005-1-002
3 Model MC-1 Manual Control Station	1	52-289-2-001
4 Model AD-1 Automatic Drain Valve	1	52-793-2-004
5 Model ASV-1 Automatic Shut-Off Valve	1	92-343-1-021
6 Item No. Not Used		
7 1/2" Ball Valve	2	46-050-1-004
8 1/2" Spring Loaded Check Valve	1	92-322-1-002
9 1/2" Y-Strainer	1	52-353-1-005
10 3/4" Swing Check Valve	1	46-049-1-005
11 1" Angle Valve	1	46-048-1-006
12 2" Angle Valve	1	46-048-1-009
13 Drip Funnel Connector	1	92-211-1-005
14 Drip Funnel Bracket	1	92-211-1-003

NO. DESCRIPTION	QTY.	P/N
15 Drip Funnel	1	92-343-1-007
16 3/32" Vent Fitting	1	92-032-1-002
17 Select Tubing per Table	1	CH
18 1/2" Tubing Connector	1	CH
19 1/2" x 24" Tubing	1	CH
20 1/4" Plug	1	CH
21 3/4" Plug	1	CH
22 1/2" Union	5	CH
23 1" Union	2	CH
24 1/4" 90° Elbow	1	CH
25 1/2" 90° Elbow	8	CH
26 1" 90° Elbow	1	CH
27 1/2" Tee	3	CH
28 1/2" x 1/4" x 1/2" Tee	3	CH

NO. DESCRIPTION	QTY.	P/N
29 3/4" x 1/2" x 3/4" Tee	2	CH
30 1" x 1" x 1/2" Tee	1	CH
31 1" x 3/4" x 1" Tee	1	CH
32 2" x 1" x 2" Tee	1	CH
33 1/4" x Close Nipple	2	CH
34 1/2" x Close Nipple	2	CH
35 1/2" x 1-1/2" Nipple	10	CH
36 1/2" x 2-1/2" Nipple	3	CH
37 Select Nipple per Table	1	CH
38 1/2" x 5" Nipple	2	CH
39 1/2" x 6" Nipple	1	CH
40 1/2" x 7" Nipple	2	CH
41 Select Nipple per Table	1	CH
42 Select Nipple per Table	1	CH
43 Select Nipple per Table	1	CH
44 3/4" x 1-1/2" Nipple	1	CH
45 3/4" x 2" Nipple	1	CH
46 Select Nipple per Table	1	CH
47 1" x Close Nipple	5	CH
48 1" x 3" Nipple	1	CH
49 Select Nipple per Table	1	CH
50 2" x 3" Nipple	1	CH
51 2" x 5" Nipple	1	CH
52 Select Nipple per Table	1	CH

E1 Solenoid Valve Ordered Separately	Refer to
Per Data Sheet TFP2180	Data Sheet
E2 1/2" Tubing Connector	1 CH
E3 1/2" x 24" Tubing	1 CH
E4 1/2" x 1-1/2" Nipple	1 CH

COMPONENTS ORDERED SEPARATELY:

A1 Waterflow Pressure Alarm Switch, Model PS10-2	1	25710
------------------------------------------------------------	---	-------

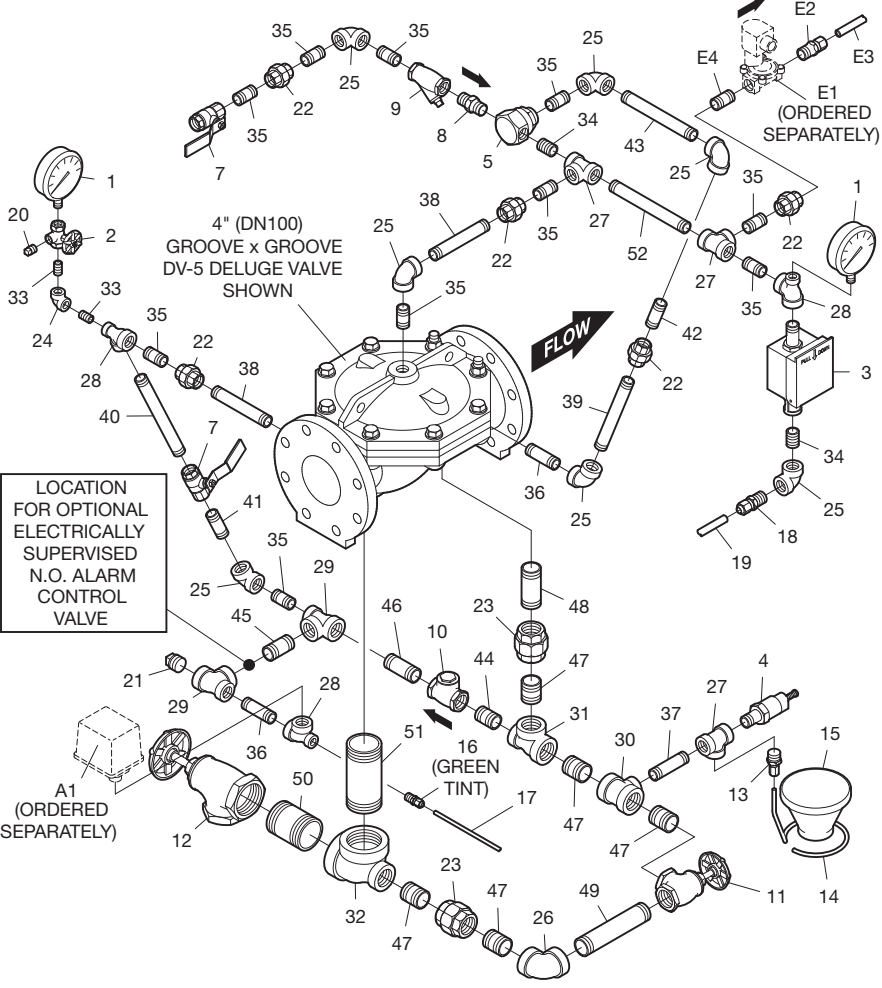

Tube No.	Select Appropriate Tube Size per DV-5 Deluge Valve Size		
	4" (DN100)	6" (DN150)	8" (DN200)
17	1/4" x 24"	1/4" x 24"	1/4" x 32"

Nipple No.	Select Appropriate Nipple Sizes per DV-5 Deluge Valve Size		
	4" (DN100)	6" (DN150)	8" (DN200)
37	1/2" x 3"	1/2" x 3"	1/2" x 5"
41	1/2" x 2-1/2"	1/2" x 5-1/2"	1/2" x 8-1/2"
42	1/2" x 2"	1/2" x 3"	1/2" x 3-1/2"
43	1/2" x 6-1/2"	1/2" x 7-1/2"	1/2" x 9"
46	3/4" x 2-1/2"	3/4" x 3-1/2"	3/4" x 4-1/2"
49	1" x 6"	1" x 9"	1" x 12"
52	1/2" x 7"	1/2" x 7"	1/2" x 9"

- NOTES:
1. Electric Actuation Trim is comprised of Items 1-52 plus Items E2-E4. Items A1 and E1 ordered separately.
 2. All Fittings and Nipples are galvanized (Standard Order).
 3. CH: Common Hardware.
 4. See Figure 2 of TFP1305 for Valve Port identification.
 5. Route all Tubing to Drip Funnel, Item 15.
 6. Horizontal Arrangement uses only 7 out of 8 of Item 25, and 2 out of 3 of Item 36. Discard unused material.

FIGURE 5 (3 OF 3)
4, 6, AND 8 INCH (DN100, DN150, AND DN200) DV-5 DELUGE VALVES
EXPLODED VIEW OF HORIZONTAL ELECTRIC ACTUATION TRIM

Valve Setting Procedure

Steps 1 through 11 are to be performed when initially setting the DV-5 Deluge Valve; after an operational test of the fire protection system; or, after system operation due to a fire.

NOTE: *When the system is using either a seawater or brackish water supply, it is recommended that the system be thoroughly flushed with clean fresh water. Following this recommendation will increase the service life of the DV-5 Valve and Trim.*

Step 1. Close the Main Control Valve.

Step 2. Close the Diaphragm Chamber Supply Control Valve.

Step 3. Open the Main Drain Valve, System Drain Valve, and all auxiliary drains in the system. Close the System Drain Valve and auxiliary drain valves after water ceases to discharge. Leave the Main Drain Valve open.

Step 4. Depress the plunger of the Automatic Drain Valve to verify that it is open and that the DV-5 Valve is completely drained.

Step 5. Clean the Strainer in the Diaphragm Chamber Supply connection by removing the clean-out plug and strainer basket. The Strainer may be flushed out by momentarily opening the Diaphragm Chamber Supply Control Valve.

Step 6. Reset the actuation system.

Manual Actuation — Push the operating lever up; however, do not close the hinged cover at this time.

Electric Actuation — Reset the electric detection system in accordance with the manufacturer's instructions to de-energize the solenoid valve.

Step 7. Open the Diaphragm Chamber Supply Control Valve and allow time for full pressure to build up in the Diaphragm Chamber.

Step 8. Operate (open) the Manual Control Station to vent trapped air from the Diaphragm Chamber. If necessary, first open the hinged cover, and then fully pull down on the operating lever. Slowly close the operating lever, by pushing it up, after aerated water ceases to discharge from the Manual Control Station drain tubing. Close the hinged cover and insert a new break rod in the small hole through the top of the enclosing box.

Step 9. Inspect the drain connections from the Manual Control Station and Solenoid Valve. Any leaks must be corrected before proceeding to the next step.

Step 10. Verify the ability for the DV-5 Diaphragm to hold pressure as follows:

With the diaphragm chamber pressurized per Step 8, temporarily close the Diaphragm Chamber Supply Control Valve, and then monitor the Diaphragm Chamber Pressure Gauge for a drop in pressure.

If a drop in pressure is noted, the DV-5 Diaphragm is to be replaced and/or any leaks must be corrected before proceeding to the next step.

If the Diaphragm Chamber Pressure Gauge indicates no drop in pressure, re-open the Diaphragm Chamber Supply Control Valve and proceed to the next step.

Step 11. Slowly open the Main Control Valve. Close the Main Drain Valve as soon as water discharges from the drain connection. Observe the Automatic Drain Valve for leaks. If there are leaks, determine/correct the cause of the leakage problem. If there are no leaks, the DV-5 Valve is ready to be placed in service and the Main Control Valve must then be fully opened.

NOTE: *When the Main Control Valve is opened, the pressure on the Diaphragm Chamber may increase. This increase in pressure is normal, and if the pressure is greater than 250 psi (17,2 bar), the pressure is to be relieved by partially and temporarily opening the Manual Control Station; however, do not allow the pressure as indicated on the Diaphragm Chamber Pressure Gauge to drop below the supply pressure shown on the Water Supply Pressure Gauge, since this action may result in tripping of the DV-5 Valve.*

After setting a fire protection system, notify the proper authorities and advise those responsible for monitoring proprietary and/or central station alarms.

Care and Maintenance

The following procedures and inspections must be performed as indicated, in addition to any specific requirements of the NFPA, and any impairment must be immediately corrected.

Before closing a fire protection system Main Control Valve for maintenance work on the fire protection system that it controls, permission to shut down the affected fire protection systems must first be obtained from the proper authorities and all personnel who may be affected by this action must be notified. Reset the DV-5 Deluge Valve in accordance with the Valve Setting Procedure section.

The owner is responsible for the inspection, testing, and maintenance of their fire protection system and devices in compliance with this document, as well as with the applicable standards of the National Fire Protection Association (e.g., NFPA 25), in addition to the standards of any authority having jurisdiction. Contact the installing contractor or product manufacturer with any questions.

It is recommended that automatic sprinkler systems be inspected, tested, and maintained by a qualified Inspection Service in accordance with local requirements and/or national codes.

NOTICE

Some of the procedures outlined in this section will result in operation of the associated alarms. Consequently, notification must first be given to the owner and the fire department, central station, or other signal station to which the alarms are connected.

When the system is using either a seawater or brackish water supply, internal and external inspection of the DV-5 Valve and Trim is essential. Parts showing any signs of corrosion must be replaced to ensure the integrity of the system.

Annual Operation Test Procedure

Proper operation of the DV-5 Valve (i.e., opening of the DV-5 Valve as during a fire condition) must be verified at least once a year as follows:

Step 1. If water must be prevented from flowing beyond the riser, perform the following steps:

- Close the Main Control Valve.
- Open the Main Drain Valve.
- Open the Main Control Valve one turn beyond the position at which water just begins to flow from the Main Drain Valve.
- Close the Main Drain Valve.

Step 2. Test the Deluge Valve Releasing Panel in accordance with the manufacturer's instructions to energize the solenoid valve.

NOTE: *Be prepared to quickly perform Steps 3, 4, and 5, if water must be prevented from flowing beyond the riser.*

Step 3. Verify that the DV-5 Valve has tripped, as indicated by the flow of water into the system.

Step 4. Close the system's Main Control Valve.

Step 5. Close the Diaphragm Chamber Supply Control Valve.

Step 6. Reset the DV-5 Deluge Valve in accordance with the Valve Setting Procedure.

Quarterly Waterflow Alarm Test Procedure

Testing of the system waterflow alarms must be performed quarterly. To test the waterflow alarm, open the Alarm Test Valve, which will allow a flow of water to the Pressure Alarm Switch and/or Water Motor Alarm. Upon satisfactory completion of the test, close the Alarm Test Valve.

Ordering Procedure

NOTE: Part Numbers for factory pre-trimmed DV-5 Valves are provided in the Price Book.

DV-5 Semi-Preassembled Vertical Electric Actuation Trim

Specify: (specify size and finish — galvanized is standard) Semi-Preassembled Vertical Electric Actuation Trim for DV-5 Deluge Valves, P/N (specify):

- 1-1/2 & 2 Inch Galvanized . . . P/N 52-477-2-309
- 1-1/2 & 2 Inch Black P/N 52-477-1-309
- 1-1/2 & 2 Inch Brass P/N 52-477-3-309

- 3 Inch Galvanized P/N 52-477-2-106
- 3 Inch Black P/N 52-477-1-106
- 3 Inch Brass P/N 52-477-3-106

- 4, 6 & 8 Inch Galvanized P/N 52-477-2-303
- 4, 6 & 8 Inch Black P/N 52-477-1-303
- 4, 6 & 8 Inch Brass P/N 52-477-3-303

DV-5 Unassembled Electric Actuation Trim for Vertical or Horizontal Installation

Specify: (specify size and finish — galvanized is standard) Unassembled Electric Actuation Trim for Vertical or Horizontal Installation of DV-5 Deluge Valves, P/N (specify):

- 1-1/2 & 2 Inch Galvanized . . . P/N 52-477-2-209
- 1-1/2 & 2 Inch Black P/N 52-477-1-209
- 1-1/2 & 2 Inch Brass P/N 52-477-3-209

- 3 Inch Galvanized P/N 52-477-2-206
- 3 Inch Black P/N 52-477-1-206
- 3 Inch Brass P/N 52-477-3-206

- 4, 6 & 8 Inch Galvanized P/N 52-477-2-203
- 4, 6 & 8 Inch Black P/N 52-477-1-203
- 4, 6 & 8 Inch Brass P/N 52-477-3-203

Pre-trimmed DV-5 Assembly Electric Actuation Trim with Butterfly Valve

Specify: (size), G x G End Connection, Pre-trimmed DV-5 Assembly with Butterfly Valve, P/N (specify):

- 1-1/2 Inch G x G P/N 52-913-0-1AP
- 2 Inch G x G P/N 52-923-0-1AP
- 3 Inch G X G P/N 52-933-0-1AP
- 4 Inch G x G P/N 52-943-0-1AP
- 6 Inch G x G P/N 52-963-0-1AP
- 8 Inch G x G P/N 52-983-0-1AP

Pre-trimmed DV-5 Assembly Electric Actuation Trim without Butterfly Valve

Specify: (specify size), (specify) End Connection, Pre-trimmed DV-5 Assembly without Butterfly Valve, P/N (specify):

- 1-1/2 Inch T x T P/N 52-913-3-1AP
- 2 Inch T x T P/N 52-923-3-1AP
- 3 Inch F x F P/N 52-933-1-1AP
- 3 Inch F x G P/N 52-933-2-1AP
- 4 Inch F x F P/N 52-943-1-1AP
- 4 Inch F x G P/N 52-943-2-1AP
- 6 Inch F x F P/N 52-963-1-1AP
- 6 Inch F x G P/N 52-963-2-1AP
- 8 Inch F x F P/N 52-983-1-1AP
- 8 Inch F x G P/N 52-983-2-1AP

Accessories

Refer to the Technical Data Sheets for the following, as applicable, for details and additional accessories:

- 600 PSI Water Pressure Gauge P/N 92-343-1-004
- Solenoid Valve for Electric Actuation. See TFP2180
- Model PS10-2 Potter Electric Waterflow Pressure Alarm Switch P/N 25710
- Model WMA-1 Water Motor Alarm P/N 52-630-1-001

Replacement Trim Parts

Specify: (description) for use with DV-5 Deluge Valve, P/N (see Figure 3A or 5).

Accessories

Refer to the Technical Data Sheets for the following, as applicable, for details and additional accessories:

- 600 PSI Water Pressure Gauge P/N 92-343-1-004
- Model PS10-2 Potter Electric Waterflow Pressure Alarm Switch P/N 25710
- Model WMA-1 Water Motor Alarm P/N 52-630-1-001P
- Model MC-1 Manual Control Stations with Galvanized Connections for Remote Wet Pilot Actuation P/N 52-289-2-001

Replacement Trim Parts

Specify: (description) for use with DV-5 Deluge Valve, P/N (see Figure 3A or 5)