



Model AMD-2 Automatic Air Maintenance Device Compressor Control Type with Field-Adjustable Pressure Switch

General Description

The TYCO Model AMD-2 Automatic Air Maintenance Device is an automatic, field-adjustable device that controls the on-off cycling of an air compressor. It is used to control the pressure in a dry pipe sprinkler system, preaction system, or dry pilot line of a dry pilot actuated deluge or preaction valve.

The Model AMD-2 Device is utilized in applications requiring the use of a small, non-tank mounted compressor dedicated to system pressurization. The Model AMD-2 Device monitors system pressure and automatically cycles the air compressor on and off to maintain system pressure within preset limits.

The Model AMD-2 Device features a Pressure Switch with integral unloading valve that automatically bleeds the pressure between the air compressor and the Model AMD-2 Device after the air compressor automatically shuts off. This feature prevents start-up of the air compressor under load.

The Model AMD-2 Device is a re-designation for the Central Model DU-2, Gem Model F326, and Star Model S465.

NOTICE

The Model AMD-2 Automatic Air Maintenance Devices described herein must be installed and maintained in compliance with this document and with the applicable standards of the NATIONAL FIRE PROTECTION ASSOCIATION, in addition to the standards of any authorities having jurisdiction. Failure to do so may impair the performance of these devices.

Owners are responsible for maintaining their fire protection system and devices in proper operating condition. The installing contractor or sprinkler manufacturer should be contacted with any questions.

Technical Data

Approvals

UL and C-UL Listed
FM Approved
NYC Approved under MEA 206-02-E

NEMA Rating

The housing of the Pressure Switch meets NEMA 1 requirements.

Field-Adjustable Pressures

Minimum Cut-In (On) 14 psi (1,0 bar)
Maximum Cut-Out (Off) 60 psi (4,1 bar)

Pressure Switch Differential

6 psi (0,4 bar)

The switch ratings are as follows:

115 VAC, 1 Phase	2 HP
230 VAC, 1 Phase	3 HP
230 VAC, 3 Phase	5 HP
575 VAC, 3 Phase	5 HP
115 VDC	2 HP
230 VDC	2 HP

Factory-Set Outlet Pressure

35 to 41 psi (2,4 to 2,8 bar)

Assembly

Major components illustrated in Figure 1 are factory-assembled, galvanized steel nipples and malleable iron pipe fittings.



Operation

The By-Pass Valve in the Model AMD-2 Automatic Air Maintenance Device is opened to quickly fill the system during initial pressurization. After the cut-out pressure of the Pressure Switch is reached, its actuating lever transfers the DPDT switch contacts to shut off the air compressor and open the unloader valve to bleed pressure between the air compressor and the Restrictor Check Valve. The By-Pass Valve is then closed to place the Model AMD-2 Device in automatic operation.

The Restrictor Check Valve prevents the unloader valve from bleeding down the system. With the By-Pass Valve closed, its 3/32 in. (2,4 mm) orifice limits air flow into the system to a value significantly less than that exhausted by the operation of a 5.6 K-factor sprinkler.

When there is a small leak in the system, the Pressure Switch automatically transfers its contacts at the cut-in pressure to start the air compressor and shuts off the air compressor after the cut-out pressure is reached.

IMPORTANT

Refer to Technical Data Sheet TFP2300 for warnings pertaining to regulatory and health information.

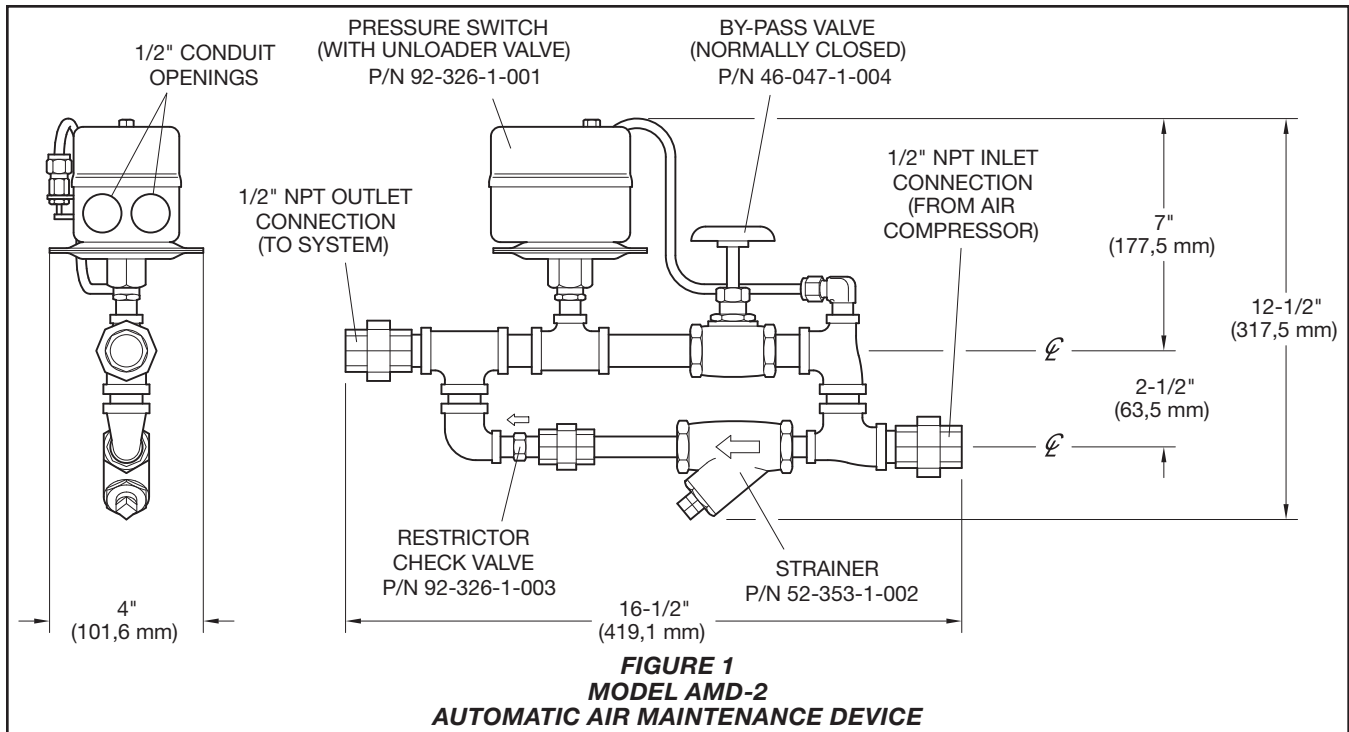

Installation

The TYCO Model AMD-2 Automatic Air Maintenance Device should be installed in the horizontal position as shown in Figure 1, as well as in accordance with the following instructions.

NOTICE

Moisture build-up can adversely affect performance. Suitable consideration must be given to the removal of excessive moisture from the compressed air supply.

1. Make connections a minimum of 1/2 in. (DN15) pipe size between the air compressor and the Model AMD-2 Device, as well as between the Model AMD-2 Device and the system to pressurize.
2. If a moisture filter with integral drain is not installed at the outlet of the air compressor, install a Drip Leg in the air line between the Air Compressor and the Model AMD-2 Device as shown in Figure 2.
3. Place a 1/2 in. (DN15), non-spring loaded, rubber-faced, swing-type check valve between the Model AMD-2 Device and the system to pressurize. A check valve of this type is provided in the air supply trim of TYCO dry pipe valves, pre-action valves, and dry pilot trim.

4. Make conduit and electrical connections to the Pressure Switch in accordance with the requirements of the authority having jurisdiction and/or the National Electrical Code. Refer to Figure 3 for identification of the wiring terminals.

The Pressure Switch is wired through two, 1/2 in. Conduit Openings in the base of its enclosure. The No. 8 screw terminals accept up to No. 12 AWG wire.

Setting Procedure

The TYCO Model AMD-2 Automatic Air Maintenance Device must be set in accordance with the following instructions.

1. Open the By-Pass Valve in the Model AMD-2 Device.
2. Open the control valve in the air supply trim to the system to pressurize.
3. To pressurize the system, apply electrical power to the Pressure Switch.
4. Close the By-Pass Valve after the Pressure Switch cuts out. Note the cut-out pressure.

5. Open a connection to the system slowly enough to reduce the air pressure and close it immediately after the Pressure Switch cuts in.

Verify that the cut-in pressure meets the minimum requirements of the system to pressurize, and note the cut-out pressure.

If necessary, remove the cover from the Pressure Switch and adjust the cut-in pressure adjustment screw shown in Figure 3. The cut-in pressure changes approximately 1.5 psi (0,1 bar) per half-turn of the screw.

The cut-in pressure should be set at the minimum required value, in order to minimize the time to system trip in the event of a sprinkler operation.

6. Repeat Step 5 if the cut-in pressure required adjustment. Note both the cut-in and cut-out pressures for future reference.

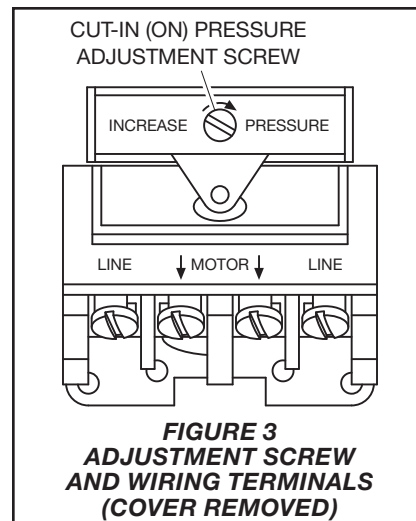
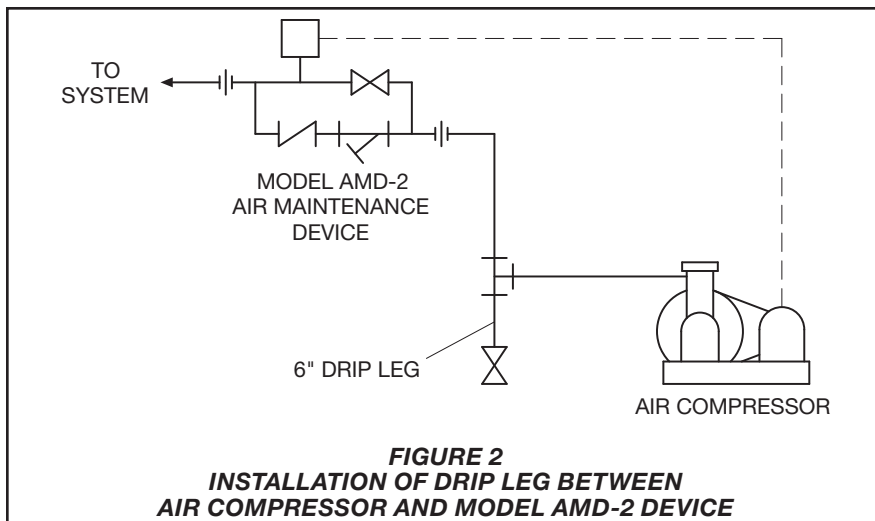

Care and Maintenance

The TYCO Model AMD-2 Automatic Air Maintenance Device must be maintained and serviced in accordance with the following instructions, in addition to any specific requirements of the NFPA. Any impairment must be immediately corrected.

NOTICE

Before closing a fire protection system main control valve for maintenance work on the fire protection system that it controls, obtain permission to shut down the affected fire protection system from the proper authorities and notify all personnel who may be affected by this action.

Do not allow condensed moisture to back-up into the air compressor cylinder.

It is recommended that accumulated moisture be removed from air supply moisture filtration equipment at least quarterly. More frequent inspections may be necessary in particularly humid environments.

After placing a fire protection system in service, notify the proper authorities and advise those responsible for monitoring proprietary and/or central station alarms.

Responsibility lies with owners for the inspection, testing, and maintenance of their fire protection system and devices in compliance with this document, as well as with the applicable standards of the NATIONAL FIRE PROTECTION ASSOCIATION (for example, NFPA 25), in addition to the standards of any other

authorities having jurisdiction. Contact the installing contractor or sprinkler manufacturer regarding any questions.

Automatic sprinkler systems are recommended to be inspected, tested, and maintained by a qualified Inspection Service in accordance with local requirements and/or national code.

The Model AMD-2 Automatic Air Maintenance Device must be inspected quarterly in accordance with the following instructions.

7. Verify that the Model AMD-2 Bypass Valve is closed.
8. Clean out the 1/4 in. Model AMD-2 Strainer located at the inlet to the Restrictor Check Valve. Be sure to re-install the strainer screen and tighten the cap securely.
9. Close the system's main control valve and open the main drain valve. Close the accelerator control valve, if the system is so equipped.
10. Open a connection to the system slowly enough to reduce the air pressure and close it immediately after the Pressure Switch cuts in. Verify that the cut-in and cut-out pressures are essentially the same as the previously established requirements.
11. Open the accelerator control valve, as applicable.
12. Slowly open the main control valve and after water begins to flow, slowly close the main drain valve. Completely open the main control valve. The Model AMD-2 Device is now ready for service.

Ordering Procedure

Contact your local distributor for availability. When placing an order, indicate the full product name, including description and Part Number (P/N).

Model AMD-2 Device

Specify: Model AMD-2 Automatic Air Maintenance Device, P/N 52-326-2-001

Replacement Parts

Specify: (description) for use with the Model AMD-2 Automatic Air Maintenance Device, P/N (from Figure 1)

