



## IS Multi-turn Gearbox Series

The IS series of multi-turn operators has been designed with customer stocking in mind, and features a removable output sleeve to facilitate spindle machining.

Operating temperature normally ranges from -40 to 120 °C, although other temperature ranges are available on request.

Standard input (for actuation) and output flanges are to ISO5210. However, equivalent standards such as DIN can be supplied.

### Application

Rotork IS series operators are multi-turn devices intended for the operation of gate, globe, sluice and penstock valves. The gearboxes are suitable for manual and motorised applications.

### Environmental Specification

Enclosure IP67 standard suitable for submerged duty up to a depth of 1 metre for 30 minutes.

Enclosure IP68 continuous submerged duty up to a maximum depth of 15 metres.

## IS Multi-turn

### Cast Iron Housing Gearboxes

#### Features

- Totally enclosed gearing
- Grease filled for life and fully sealed
- Comprehensive gear ratios
- Removable output sleeve
- Spur and bevel combinations available
- Input gear mounted on ball bearings

#### Options

- Upward or downward oriented input
- Auxiliary spur/bevel input reducers
- Input flanges for motorisation
- Two speed spur input reducers
- High and low temperatures
- Padlockable handwheels
- Nuclear
- IP68
- Buried duty
- Raw sewage
- Mechanical dial position Indicator
- Flexible extensions
- Firesafe to ISO 10497
- Interlock safety system

## IS Multi-turn Cast Iron Housing Gearboxes

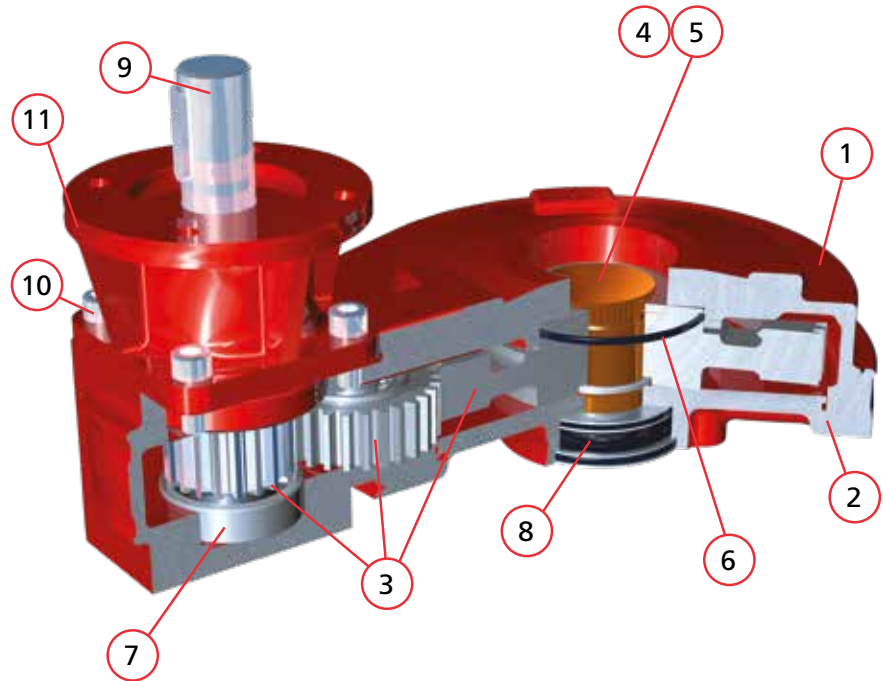

### Material Specification for Rotork IS Range of SPUR Gear Valve Operators

No.	Description	Material	UK Standard	USA Standard	DIN Standard
1	Gearcase (IS2 to IS7, IS12 & IS13)	Cast Iron	BS1561 EN-GJL-250	ASTM A48 35B/40B	GG-25
	Gearcase (IS8 to IS11 & IS15 to IS20)	SG Iron	BS1563 EN-GJS-450-10	ASTM A536 65-45-12	GGG-40
2	Baseplate	SG Iron	BS1561 EN-GJS-450-10	ASTM A536 65-45-12	GGG-40
3	Gears	SG Iron	BS1563 EN-GJS-700-2	AISI/SAE 1010 or 4340	GGG-70
		Steel	BS970 605M36T		
4	Output Sleeve Form B	Steel	BS970 070M20	ASIS/SAE 1023	C22
5	Output Sleeve Form A	Aluminium Bronze	BS1400 AB2	ASTM B505 C95800	
6	Seals	Nitrile Rubber			
7	Input Shaft bearings	Ball Bearings			
8	Output Thrust Bearings	Needle Roller Bearings (with the exception of output sizes 14, 16, 18, 19 & 20 which has Roller Thrust Bearings)			
9	Input Shaft	Steel	BS970 605M36T	AISI/SAE 4340	42 MnMo 7
10	Fasteners	Steel	BS3692 & BS4168		
11	Input Housing	Cast Iron	BS1561 EN-GJL-250	ASTM A48 35B/40B	GG-25
	Grease	Renolit CL-X2			
	Finish	PE3 Grey Primer (other finishes available on request)			

Note: Because of the company's policy of continuous improvement, Rotork reserves the right to change specification details without prior notice.

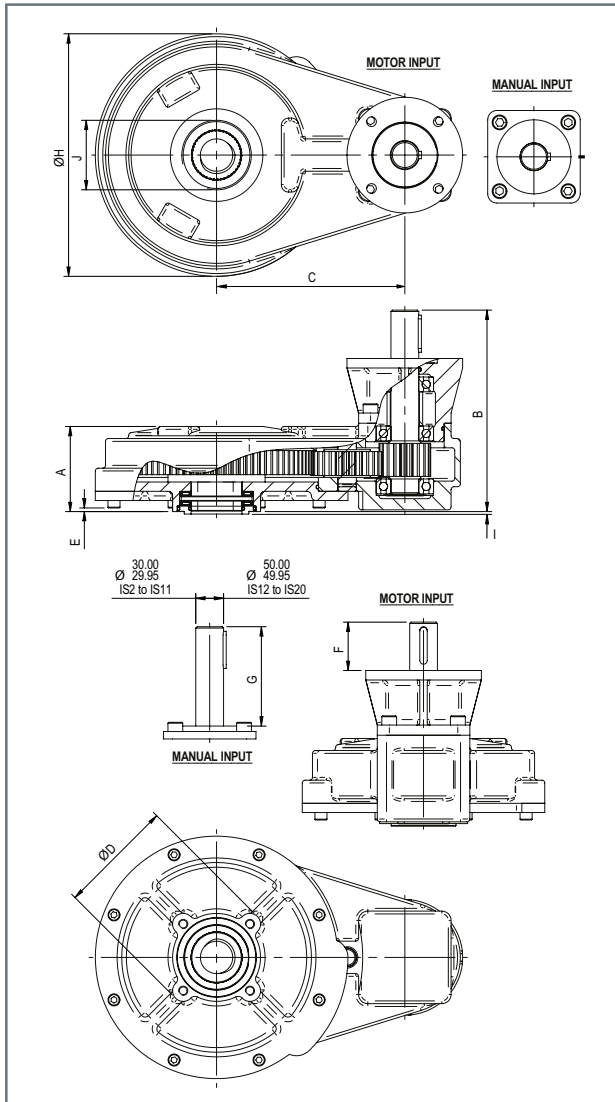

### Input Flange Details

Input	Flange Dia. & Thickness	Shaft Dia.	Key Details
F10 & FA10	Ø125 x 10	Ø20.00 - 0.05	6 x 6 x 40
F14 & FA14	Ø175 x 15	Ø30.00 - 0.05	8 x 7 x 40
F16 & FA16	Ø210 x 20	*Ø40.00 - 0.05	**12 x 8 x 55
F25 & FA25	Ø300 x 20	Ø50.00 - 0.05	14 x 9 x 55
F30	Ø350 x 20	Ø50.00 - 0.05	14 x 9 x 80
ROTORK G30	Ø418 x 20	Ø50.00 - 0.05	14 x 9 x 80

\* Ø30.00 for IS6 & IS7.

\*\* 8 x 7 x 40 for IS6 & IS7.

Gearbox	Max Bore Rectangular Key BS4235	Max Acme Thread (Inch) (mm)	Weight (Kg)
IS2	40.0	1 3/4"	19
IS3	52.0	2 1/8"	20
IS4	40.0	1 3/4"	25
IS5	52.0	2 1/8"	30
IS6	52.0	2 1/8"	45
IS7	68.0	2 7/8"	50
IS8	68.0	2 7/8"	75
IS9	76.0	3 3/8"	82
IS10	76.0	3 3/8"	108
IS11	96.0	3 7/8"	122
IS12	96.0	3 7/8"	185
IS13	121.0	5"	220
IS15	121.0	5"	270 (F35), 305 (F40)
*IS16	130.0	5 7/8"	400
IS17	121.0	5"	536
*IS18	130.0	5 7/8"	658
**IS19	170.0	7 3/8"	607 (F40), 764 (F48)
***IS20	206.0	8 3/4"	745 (F48), 980 (F60)
****IS21	206.0	8 3/4"	1052

Aluminium bronze output sleeve supplied with cast pilot bore as standard.

Cast bores \*Ø60 or optional Ø40, \*\*Ø90 or optional Ø50 and \*\*\*Ø100.

\*\*Machined bore Ø75 or optional Ø62.

Gearbox	Ratio	A	B	C	ØD	E	F	G	ØH	I	J	Input Options	Output Options
IS2	1, 2 & 3:1	87	221	153	125	-5	51	113	172	3	2.5 BSP or NPT	F10 & F14	F10
IS3	1, 2 & 3:1	109	230	153	172	17	51	113	172	4	2.5 BSP or NPT	F10 & F14	F14
IS4	2, 3, 4 & 6:1	92	221	204	125	4	51	113	262	3	2.5 BSP or NPT	F10 & F14	F10
IS5	2, 3, 4 & 6:1	115	239	204	175	27	51	113	262	4	2.5 BSP or NPT	F10 & F14	F14
IS6	2, 3, 4, 6 & 8:1	119	235	305	166	4	51	113	330	4	3.5 BSP or NPT	F10, F14 & F16	F14
IS7	2, 3, 4, 6 & 8:1	120	236	305	200	5	51	113	330	5	3.5 BSP or NPT	F10, F14 & F16	F16
IS8	4, 6, 8, 10, 12 & 15:1	183	343	333	210	38	60	155	330	5	4 BSP or NPT	F10, F14, F16 & F25	F16
IS9	4, 6, 8, 10, 12 & 15:1	189	349	333	300	44	60	155	330	5	4 BSP or NPT	F10, F14, F16 & F25	F25
IS10	4, 6, 8, 10, 12 & 15:1	221	376	356	300	41	60	155	412	5	5 BSP or NPT	F14, F16 & F25	F25
IS11	4, 6, 8, 10, 12 & 15:1	242	397	356	350	62	60	155	412	5	5 BSP or NPT	F14, F16 & F25	F30
IS12	8, 10, 12 & 15:1	282	437	407	350	62	60	155	412	5	-	F14, F16 & F25	F30
IS13	8, 10, 12 & 15:1	298	453	407	410	78	60	155	520	5	-	F14, F16 & F25	F35
IS15	10, 12 & 15:1	413	564	454	410	72	60	155	520	5/8	-	F14, F16 & F25	F35, F40
IS16	10, 12 & 15:1	525	676	454	476	184	60	155	520	8	-	F14, F16 & F25	F40
IS17	15 & 24:1	483	663	610	410	72	90	185	705	5	-	F16, F25, F30 & F35	F35
IS18	15 & 24:1	595	775	610	476	184	90	185	705	8	-	F16, F25, F30 & F35	F40
IS19	15 & 24:1	647	827	610	476	236	90	185	705	8	-	F16, F25, F30 & F35	F40, F48
IS20	15 & 24:1	710	890	610	555	299	90	185	705	8	-	F16, F25, F30 & F35	F48, F60
IS21	15 & 24:1	780	960	610	TBC	369	90	185	705	8	-	F16, F25, F30 & F35	F60

All dimensions in mm.

#### Gearbox Selection Chart

Gearbox	Nominal Ratio					Exact Ratio					Manual Output Torque (Nm)	Max Manual Thrust (kN)	Motorised Output Torque (Nm)	Max Motorised Thrust (kN)	Mechanical Advantage ±10%*							
	1	2	3	6	8	1.25	2.04	3.00	6.00	8.00					1.125	1.830	2.700	5.400	7.200			
IS2	1	2	3			1.25	2.04	3.00			508	54	406	53	1.125	1.830	2.700					
IS3	1	2	3			1.25	2.04	3.00			508	178	406	177	1.125	1.830	2.700					
IS4	2	3	4	6		2.12	3.00	4.10	6.00		850	54	678	53	1.900	2.700	3.690	5.400				
IS5	2	3	4	6		2.12	3.00	4.10	6.00		850	178	678	177	1.900	2.700	3.690	5.400				
IS6	2	3	4	6	8	2.00	3.00	4.00	6.00	8.00	1700	178	1355	177	1.800	2.700	3.600	5.400	7.200			
IS7	2	3	4	6	8	2.00	3.00	4.00	6.00	8.00	1700	356	1355	266	1.800	2.700	3.600	5.400	7.200			
IS8	4	6	8	10	12	15	4.01	6.10	7.95	10.20	12.26	15.03	2550	356	2033	266	3.600	5.490	7.156	9.180	11.030	13.520
IS9	4	6	8	10	12	15	4.01	6.10	7.95	10.20	12.26	15.03	2550	445	2033	355	3.600	5.490	7.156	9.180	11.030	13.520
IS10	4	6	8	10	12	15	4.04	6.11	7.81	10.17	12.11	14.66	5423	445	4067	355	3.633	5.500	7.025	9.156	10.900	13.194
IS11	4	6	8	10	12	15	4.04	6.11	7.81	10.17	12.11	14.66	5423	670	4067	500	3.633	5.500	7.025	9.156	10.900	13.194
IS12	8	10	12	15		8.09	9.99	11.83	15.15		10846	670	8135	500	7.280	8.993	10.649	13.632				
IS13	8	10	12	15		8.09	9.99	11.83	15.15		10846	1112	8135	834	7.280	8.993	10.649	13.632				
IS15	10	12	15			9.86	12.00	15.00			19000	1112	16270	834	8.870	10.800	13.500					
IS16	10	12	15			9.86	12.00	15.00			19000	1557	16270	1320	8.870	10.800	13.500					
IS17	15	24				15.17	24.09				46100	1112	43386	834	13.650	21.680						
IS18	15	24				15.17	24.09				46100	1557	43386	1320	13.650	21.680						
IS19	15	24				15.17	24.09				46100	2242	43386	1668	13.650	21.680						
IS20	15	24				15.17	24.09				46100	3342	43386	2224	13.650	21.680						
IS21	15	24				15.17	24.09				46100	4350	43386	2900	13.650	21.680						

For manual torque the static safety factor is 1.5. For motorised torque the static safety factor is 2. \*The published M.A. is achieved after a few cycles.

#### Dimensions

Type	ØH	K	N
F200	200	75.5	3
F300	300	100.5	3
F400	400	100.5	4
F500	500	100.5	4
F600	600	100.5	4
F700	700	100.5	6
F800	800	100.5	6
F900	900	100.5	6
F1000	1000	100.5	6
F1100	1100	100.5	6
F1200	1200	100.5	8

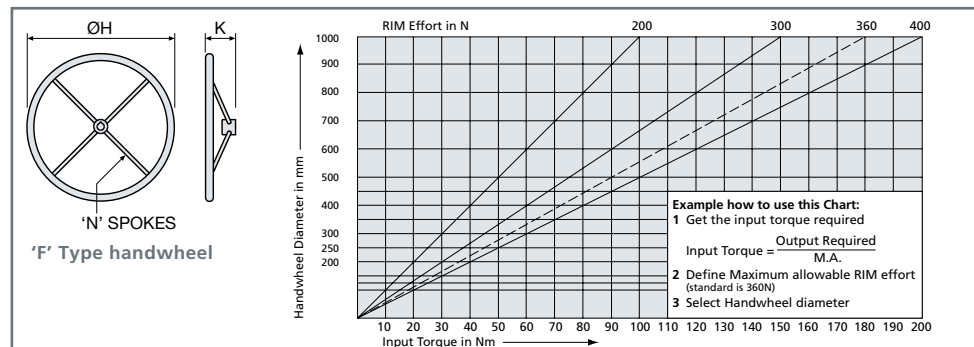

A full listing of the Rotork sales and service network is available on our website.