

rotork®

Gears

WGS Subsea Worm Gear Series



Subsea WGS Gearboxes - Worm Gear Series

The WGS series quarter-turn worm gear operators are designed for heavy duty subsea applications at any depth with carefully chosen materials to offer the highest level of reliability required in this very harsh environment.

The operators are equipped with membrane or piston type pressure compensators to balance the pressure and allow them to work at any depth.

The WGS series has a good track record in the subsea industry.

Various options are available and can be engineered per application when required.

Application

The WGS series gear operators are quarter-turn devices for the operation of subsea ball, butterfly and any other quarter-turn valves at any depth below sea level. The WGS series are designed to be operated either manually by a diver or by ROV (Remotely Operated Vehicle).

Features

- Worm shaft supported on taper roller bearings
- High strength alloy steel worm screw hardened and ground
- Self locking
- Many ratios available
- Permanent lubrication with eco-compatible oil
- Relief valve
- High visibility position indicator
- Membrane type pressure compensator
- Finish painting for subsea environment
- Vertical or horizontal mounted carbon steel ROV input from class 1 to 7
- Duplex F51 input shaft
- Handwheel for operation by diver
- Custom designed to suit project specifications
- Torque range from 2200 to 500,000 Nm
- Stroke 0 – 90° (± 5° adjustable)

Options

- Piston or open type pressure compensator
- Super Duplex material input shaft
- Tactile position indicators
- Telescopic ROV extension
- Carbon steel housing
- Aluminium Bronze worm gear
- Stainless Steel ROV bucket
- Finish painting according to customer specification
- Flexible Extensions
- SS. Duplex F55 input shaft.

Redefining Flow Control

rotork® Gears



WGS Series Subsea sizing data

Gearbox Type	Manual Duty Output Torque Max. (Nm)	Ratio for Manual Duty	Mech. Adv. +/- 10%	R.O.V. Duty Output Torque Max. (Nm)	Max. R.O.V Class ISO 13628-8	Valve Flange	 Bore & Keyway Envelope Radius L. Max. (mm)	Stem Height Max. (mm)
WGS22	2200	62:1	15.5	2500	2	F12-F14-F16-F25	36	90
WGS30	3000	146:1	36.5	2500	2	F14-F16-F25	36	90
WGS45	4500	169:1	42.2	3500	2	F16-F25	43	100
WGS100	10000	322:1	90.9	8000	2	F25-F30	58	118
WGS170	17000	570:1	126	14000	2	F25-F30-F35	64	130
WGS300	30000	855:1	205	25000	4	F30-F35-F40	88	170
WGS550	55000	855:1	240	45000	4	F35-F40-F48	100	215
WGS1000	100000	3795:1	910	80000	4	F35-F40-F48	112	250
WGS1700	170000	4760:1	1190	150000	5	F40-F48-F60	135	290
WGS3000	300000	5300:1	1325	250000	6	F48-F60	170	340
WGS5000	500000	7440:1	1945	500000	7	F60	190	400

Various ratios and MA are available for the ROV duty depending on the class and orientation.

Please contact Rotork Gears for the ROV sizing.

The published M.A. is achieved after a few cycles.

The output torque might change according to the selected ratio and project safety factor.

WGS Series Material Specification

Components	Material	DIN	EN Standard	USA Standard
Housing	Ductile iron	GGG40	EN-GJS-400-18 UNI EN1563	ASTM A536 Grade 65-45-12
Worm Screw	Alloy Steel	17NiCrMo6 Pb	17NiCrMo6.4 Pb	AISI 4317
Worm gear	Ductile iron	GGG50	EN-GJS-500-7 UNI EN1563	ASTM A536 Grade 80-55-06
Input shaft	Duplex F51	14 462	14 462	ASTM A276 UNS S31803
Stop screw	Carbon Steel	12.9 DIN 6379	12.9 UNI 3740	ASTM 193 B7
Fasteners	Stainless steel	X2CrNiMo 17-12-2	X 2 CrNiMo 17 12 2 1.4404	AISI 316L
O-Rings	Buna-N			
Compensator	Membrane			

Redefining Flow Control

WGS Subsea

Worm Gear Series

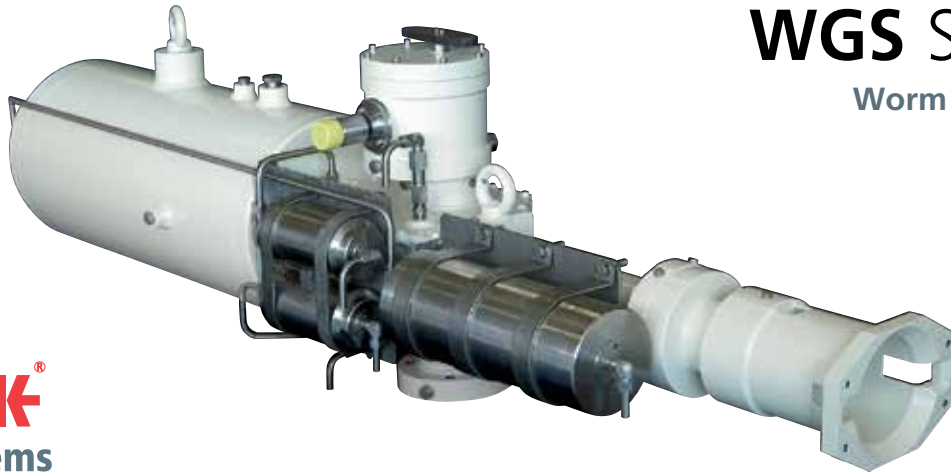

rotork[®]
Fluid Systems

Subsea series actuators

Complimenting our subsea gearboxes with diver or ROV operable over-rides is a range of subsea actuators. These are designed and engineered by the Rotork Fluid System division which has manufacturing facilities and centres of excellence around the world. The engineering groups of Rotork Fluid System and Rotork Gears share databases, engineering knowledge and test facilities to provide a comprehensive subsea solution.

For further information see publication F800 or visit the Rotork website www.rotork.com



Position transducer assembly with electrical instrumentation connector.



ISO 13628-8 Class 4 ROV receptacle for rotary torque tool operation of the actuator mechanical over-ride.

Design Options

- ROV and diver operated actuator manual override via an ISO 13628-8 torque tool receptacle.
- ROV torque tool operated over-ride lock-out.
- Diver operated handwheel multiplier that inserts into the ISO receptacle for manual operation.
- Subsea gearbox for dedicated valve operation with ISO 13628-8 receptacle for ROV torque tool.
- Adjustable extensions to facilitate remote fixing of ISO receptacle.
- Remote ISO receptacle valve position indicators (showing true actuator/gearbox position via local gearbox at the remote receptacle).
- Actuator/gearbox quick release system.
- Actuator de-clutch system to allow independent operation of the actuator when on the valve.
- Actuator and gearbox declutch system to provide interchangeability between similar pipeline valves.
- Transition spool with end of stroke position stops, flushing facility, internal relief and stem cap protection.
- Double block & bleed control manifold.
- Position transducers and limit switch assemblies that allow fitting of subsea electrical connectors.
- Torque test equipment for actuator and override performance.
- ISO 4406 Class 6 (NAS 6) flushing capabilities with fluid sampling device.
- Subsea & splashzone trims.

Handwheel Selection Chart

Dimensions

Type	A	B
S300	Ø300	200
S400	Ø400	200
S500	Ø500	200
S600	Ø600	200
S700	Ø700	300
S800	Ø800	300
S900	Ø900	300
S1000	Ø1000	300

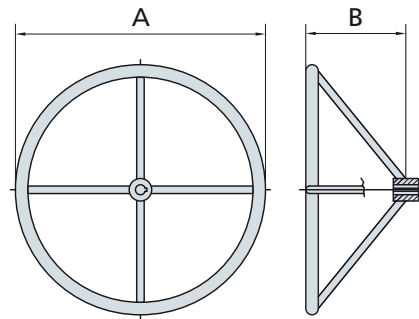

S series handwheel

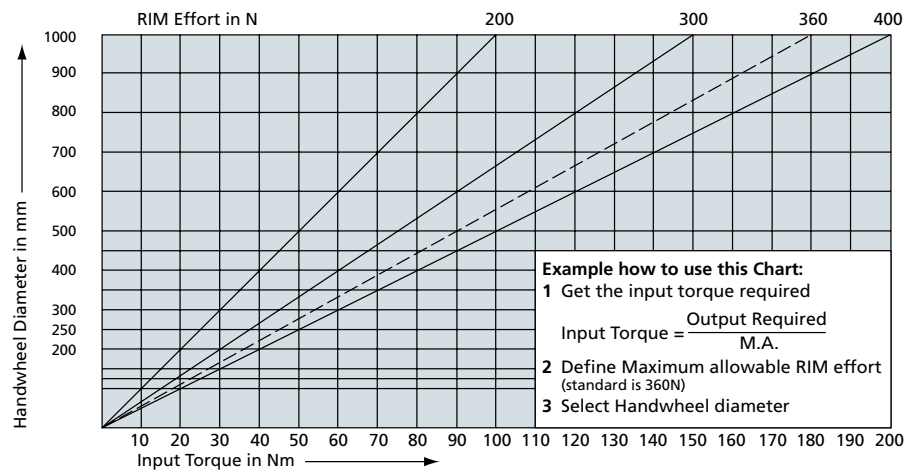

A full listing of our worldwide sales and service network is available on our website at