

JOWA USA

Wireless Resistance Transceiver (WRT)

Features:

- Self-contained signal conditioner and transceiver
- External power not required
- Intrinsically Safe – FM approved (no I.S. barriers required)
- Mounts to standard resistance-tape sensor housing
- FCC License-free operation
- Up to 3000' range (clear line of sight)
500' to 1000' with obstructions
- Completely field adjustable; simple two point calibration
- Up to 5 year battery life
- Direct communication with Wireless Base Radio (WBR)



Description:

The Wireless Resistance Transceiver, model WRT, is an ideal addition to any resistance-tape level sensor where power and signal wires do not exist. This product allows for level monitoring in places that were previously thought cost prohibitive due to the expense of running wire or adding a power source.

The model WRT is an integrated signal conditioner and RF transceiver with self-contained power operating in the 902 MHz to 928 MHz ISM license-free band.

Technical Specifications:

Inputs

- Resistance-tape sensor up to 100 feet long (30.5 meters)

Output Characteristics

- See the Wireless Base Radio description for analog and digital output options

Accuracy

- ± 0.5 ohms
- Ambient temperature effect of 10 ppm per °C

Sampling and Transmission Characteristics:

The model WRT samples sensor resistance at regular intervals. The data is then transmitted to the Base Radio for centralized monitoring and data acquisition. The user specifies how frequently the process is monitored and how often data is transmitted.

- User designates low rate and high rate conditions
- Sampling rate – user selectable from 1 to 60 seconds (low rate) and from 1 to 30 seconds (high rate)
- Transmission rate – user selectable from 1 to 60 seconds (low and high rate)

Local Configuration

- Integrated LCD with membrane switch buttons
- Display rotates through process variable and error messages, if applicable
- Configure sampling and RF parameters locally using membrane switch buttons

Wireless Resistance Transceiver (WRT)

Technical Specifications (Continued):

The optional Wireless Instrumentation Manager can be used for real-time monitoring of the process information and remote configuration of field units. The user can also set thresholds to represent “alarm” or abnormal conditions.

Power Characteristics

- Self-contained power
- 3.6 V lithium battery
- Up to five year battery life (depends on sample rate and RF update rate), field replaceable

RF Characteristics

- 902 MHz – 928 MHz frequency hopping spread Spectrum (FHSS), FCC certified ISM license-free band
- Up to 3000' range from base radio with clear line of sight; 500' to 1000' range with obstructions
- The RF module in each field unit is individually tested and calibrated over the full temperature range to ensure reliable wireless operation

Self-Diagnostics

- Low battery alarm – indicates the need to replace the battery (approximately one month warning)
- Contains extensive self-checking software and hardware that continuously monitors the operation. Any sensor or device parameter out of spec is identified and reported

Operating Temperature Range

- -40°F to +185°F (-40°C to +85°C) electronics; -20°F to 225°F
- -4°F to +158°F (-20°C to +70°C) display (full visibility)
- -40°F to +185°F (-40°C to +85°C) display (with reduced visibility)

Physical Characteristics

- GE Lexan® cover; V-0 rating and UV stable

Operating Vibration and Shock Characteristics

- Certified per IEC EN00068 2-6 (vibration) and 2-27 (shock)

Random Vibration Characteristics

- Certified to withstand 6 G's, 15 minutes per axis from 9 – 500 Hz

Electromagnetic Compatibility (CE Compliance)

- Operates within specification in fields from 80 to 1,000 MHz with field strengths to 30 V/m. Meets EN 50082-1 General Immunity Standard and EN 55011 Compatibility Emissions Standard

Industrial Certification

- Rated for industrial use -40°F to 185°F (-40°C to 85°C)
- FM NEMA 4 weather-proof housing
- FM rated intrinsically safe for Class I/II/III, Division 1, Groups A, B, C, D, E, F & G;
- Class I/II/III, Division 2, Groups A, B, C, D, F & G

Intrinsic Safety Entity Parameters

- $V_{Max} = 30$ VDC
- $I_{Max} = 100$ mA
- $P_{Max} = 900$ mW
- Maximum Operating Temperature = 85°C
- Temperature Class T4

Weight: 2 lbs (0.91 kg)

Dimensions:

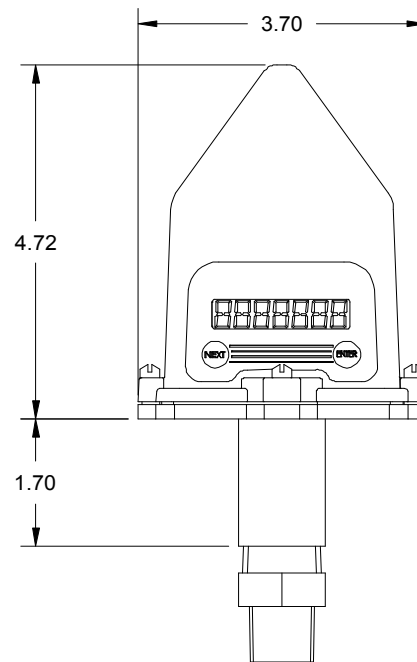

Disclaimer:

This is not a specification and all information is provided in good faith. Since conditions of use are beyond the control of JOWA USA, Inc., the information contained herein is without warranty, whether express, implied or otherwise. Final determination as to the suitability, merchantability or fitness of any information, material or product for a particular purpose, or any patent infringement, is the sole responsibility of the user. JOWA USA, Inc. does not assume liability for injury arising from the use of the information, material or product, and assumes no liability for any damages, whether direct, indirect, consequential, special, incidental, punitive or otherwise. For additional information regarding JOWA USA, Inc.'s limited warranty, refer to the Terms and Conditions that are currently in effect.

