



The Model 25 Reversing Relay provides an output which will decrease in direct proportion to an increase in input pressure.

Features

- High strength, deep convolution compensating diaphragm.
- Bottom pressure balancing chamber with a diaphragm.
- Floating seal ring.
- Balances undesirable relief seat forces.
- Ensures balanced supply seat forces.
- Protects stabilizing chamber from effect of high relief flows.

Operating Principles

The Model 25 Reversing Relay is designed for applications requiring an output that equals a manually preset spring load minus a variable signal pressure. This high quality unit combines excellent sensitivity with unusually high flow capacity.

The Model 25 is ideally suited for a variety of precision control applications, including converting direct acting valves to reverse action, controlling opposite acting valves from a single transmitter, and cushioning cylinder loads.

The basic mathematical expression for the Model 25 is $PO = K - PS$ where PO is output pressure, PS is signal pressure and K is the spring constant.

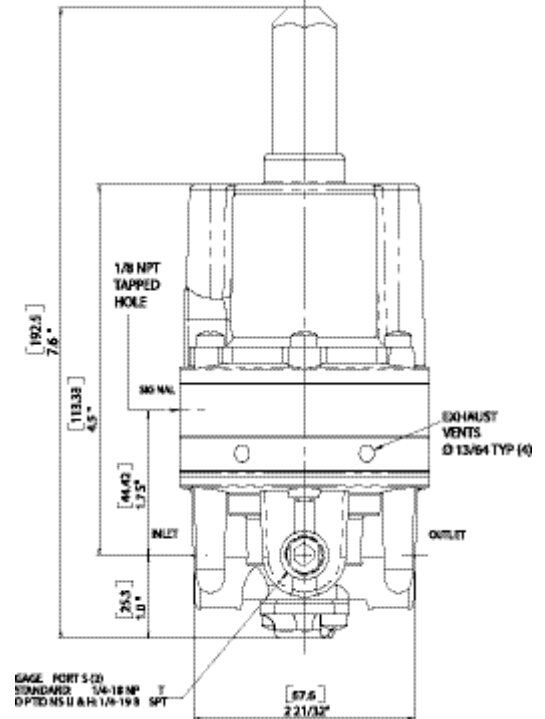
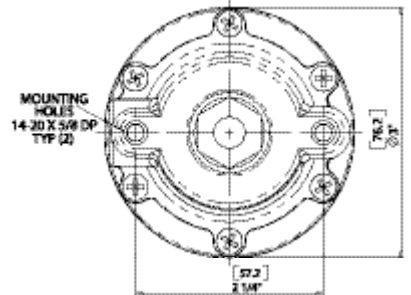
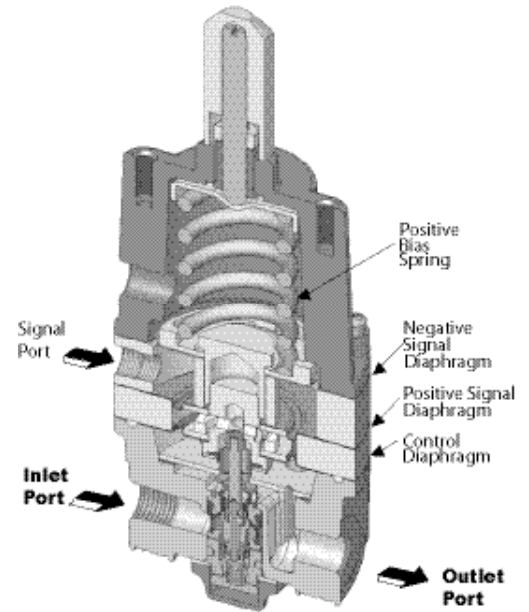

D
Model 25

Model 25 Reversing Relay

Technical Information

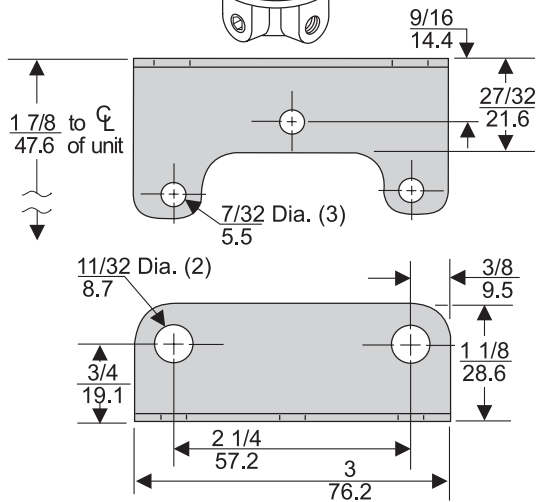
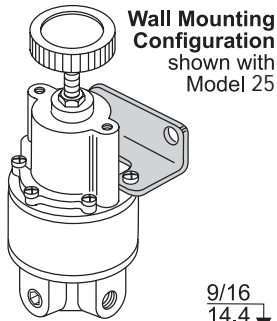
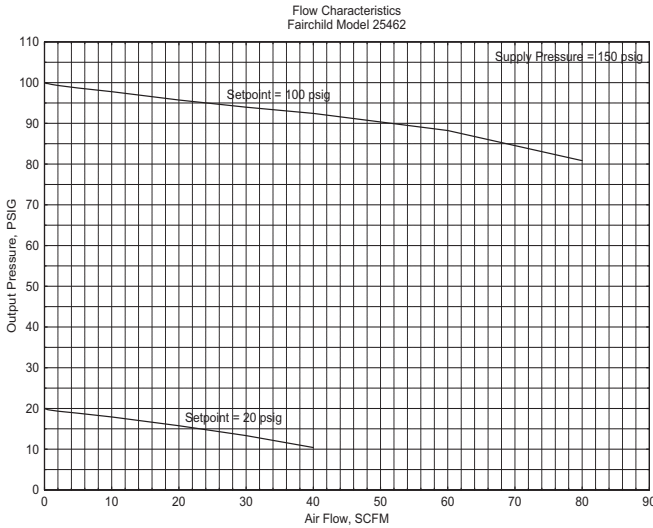

Mounting Bracket: 09921

Model 25 Relay Kits & Accessories

Mounting Bracket Kit.....09921 (sold separately)

Catalog Information

Catalog Number **2 5**

Pressure Range

psig	[BAR]	(kPa)	
0-10	[0-0.7]	(0-70)	42
0.5-30	[0.03-2]	(3-200)	43
1-60	[0.1-4]	(10-400)	44
2-150	[0.15-10]	(15-1000)	46

Pipe Size

1/4" NPT	2
3/8" NPT	3
1/2" NPT	4

Options

Tapped Exhaust	E
BSPP (Parallel) ¹	H
Fluorocarbon Elastomers	J
BSPT (Tapered)	U

¹ BSPP Threads in Inlet & Outlet Ports Only. Others BSPT.

Service Kit

A Service Kit is available for the Model 25 Reversing Relay, refer to the *Fairchild Installation, Operation and Maintenance Instructions*, IS-30000025.

Specifications

Maximum Supply Pressure

250 psig, [17.5 BAR], (1750 kPa)

Flow Capacity

40 SCFM (68 m³/HR) @ 100 psig, [7.0 BAR], (700 kPa) supply, 20 psig, [1.5 BAR], (150 kPa) setpoint

Exhaust Capacity

11 SCFM (18.7 m³/HR) where downstream pressure is 5 psig, [.35 BAR], (35 kPa) above setpoint

Signal or Output Pressure

150 psig, [10 BAR], (1000 kPa) maximum

Supply Pressure Effect

Less than 0.1 psig, [.007 BAR], (.7 kPa) for 100 psig, [7.0 BAR], (700 kPa) change in supply pressure

Sensitivity

Less than 1/8" (.32 cm) Water Column

Mounting

Pipe or Panel

Ambient Temperature Limits

-40°F to +200°F, (-40°C to 93.3°C)

Materials of Construction

BodyAluminum
TrimAluminum, Stainless Steel, Brass
DiaphragmsBuna N and Dacron