

Model 20 Pneumatic Precision Booster

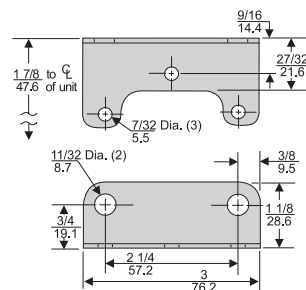

Features

- The Model 20 Pneumatic High Capacity Volume Booster uses a pneumatic input signal to accurately control output pressure
- A balanced Supply Valve minimizes the effects of supply pressure variation
- Aspirator Tube compensates downstream pressure droop under flowing conditions
- Optional Adjustable By-Pass Needle Valve option includes bubble tight exhaust valve allows tuning for optimum dynamic response (1:1 ratio only) and cycle free operation with valve positioners
- Optional Fixed Negative Bias for pneumatic signal devices that cannot be adjusted to zero signal pressure
- A separate Control Chamber isolates the diaphragm from the main flow to eliminate hunting and buzzing
- Unit construction allows servicing without removal
- Mounting Bracket available
- Canadian Registration Number (CRN) Certification for all territories and provinces

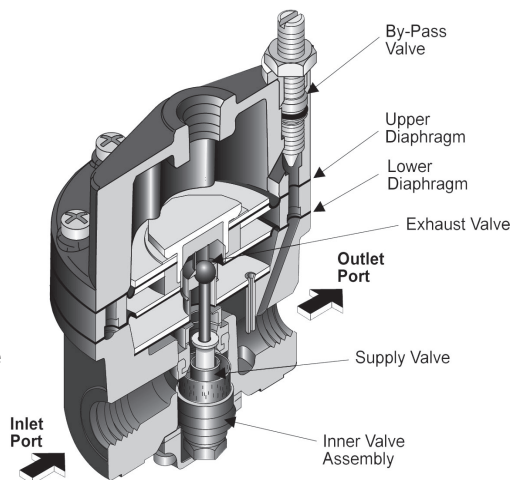

Operating Principles

The Model 20 Booster is a pneumatic device capable of high flow and exhaust capacity. This device uses a force balance system to control the movement of the supply and exhaust valves.

At set point, the force due to signal pressure that acts on the top of the Upper Diaphragm balances with the force due to output pressure acting on the bottom of the Lower Diaphragm.

Model 20 Mounting Bracket Kit
P/N 09921 (Zinc Plated Steel)
(sold separately)

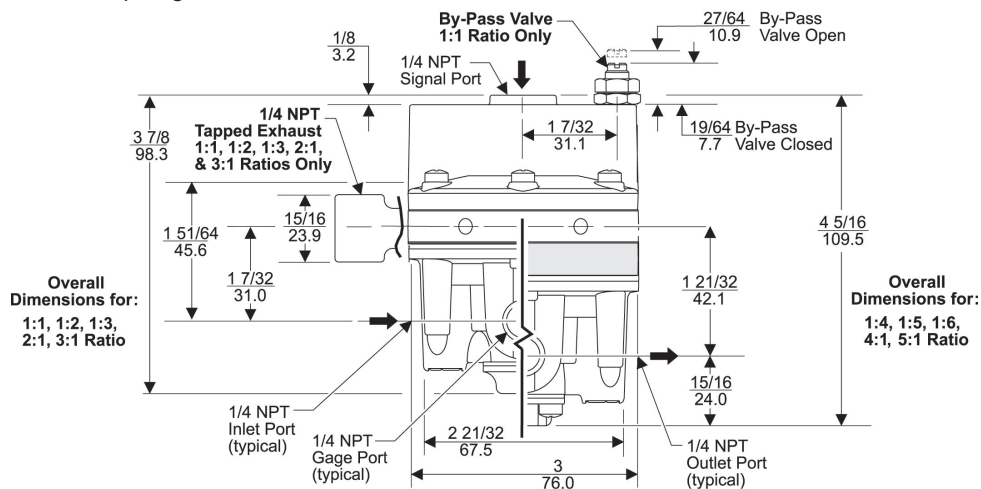

Technical Information

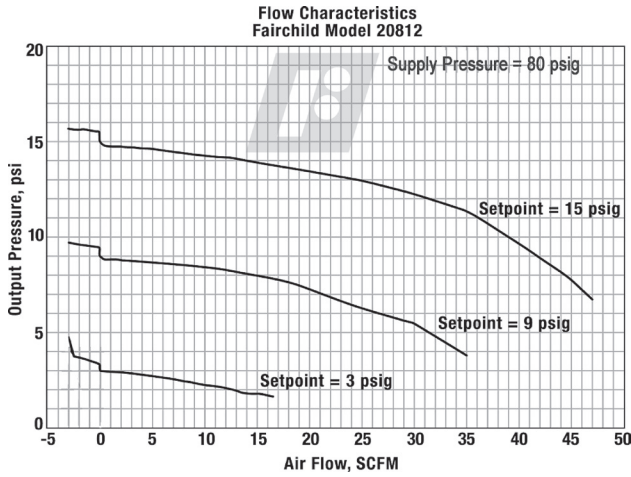

Installation

For installation instructions, refer to the *Fairchild Model 20 High Capacity Volume Booster Installation, Operation and Maintenance Instructions*, IS-20000020.

- ¹ For 1:1, 1:2, 2:1, 1:3 & 3:1 Ratios Only.
- ² Maximum Supply Pressure – 75 psig, [5.0 BAR], (500 kPa). For 1:1 Ratio Only. Not Available with I Option.
- ³ Negative Bias Fixed at 3.5 psig + 0.5 psig.
- ⁴ Not Available with Y Option. For 1:1 Ratio Only.
- ⁵ BSPP Threads in Inlet, Outlet, Bonnet & Exhaust Ports Only. Others BSPT.

Specifications

Ratio		SIGNAL:OUTPUT									
		1:1	1:2	1:3	1:4	1:5	1:6	2:1	3:1	4:1	5:1
Maximum Output Pressure	psig [BAR] (kPa)	150 [10.0] (1000)	150 [10.0] (1000)	150 [10.0] (1000)	150 [10.0] (1000)	150 [10.0] (1000)	150 [10.0] (1000)	75 [5.0] (500)	50 [3.5] (350)	37.5 [2.6] (260)	30 [2.0] (200)
Maximum Supply Pressure	psig [BAR] (kPa)	250 [17.0] (1700)	250 [17.0] (1700)	250 [17.0] (1700)	250 [17.0] (1700)	250 [17.0] (1700)	250 [17.0] (1700)	250 [17.0] (1700)	250 [17.0] (1700)	250 [17.0] (1700)	250 [17.0] (1700)
Flow Capacity SCFM, (m ³ /HR)		45 (76.5)	45 (76.5)	45 (76.5)	45 (76.5)	45 (76.5)	45 (76.5)	45 (76.5)	45 (76.5)	45 (76.5)	45 (76.5)
Exhaust Capacity SCFM, (m ³ /HR)		11 (18.7)	11 (18.7)	11 (18.7)	7.5 (12.8)	7.5 (12.8)	7.5 (12.8)	11 (18.7)	11 (18.7)	7.5 (12.8)	7.5 (12.8)
Sensitivity (water column)		1/4" (64 cm)	1/2" (1.27 cm)	3/4" (1.9 cm)	1" (2.54 cm)	1-1/4" (3.18 cm)	1-1/2" (3.8 cm)	1/2" (1.27 cm)	1/2" (1.27 cm)	3/4" (1.9 cm)	3/4" (1.9 cm)
Ratio Accuracy		1.0	1.0	1.0	2.0	2.0	2.0	-	-	-	-
Supply Pressure Effect for change of 100 psig, [7.0 BAR], (700 kPa).	psig [BAR] (kPa)	0.10 [.007] (0.7)	0.20 [.014] (1.4)	0.30 [.021] (2.1)	0.40 [.028] (2.8)	0.50 [.034] (3.4)	0.60 [.041] (4.1)	0.10 [.007] (0.7)	0.10 [.007] (0.7)	0.10 [.007] (0.7)	0.10 [.007] (0.7)
Ambient Temperature	°F	-40 to 200	-40 to 200	-40 to 200	-40 to 200	-40 to 200	-40 to 200	-40 to 200	-40 to 200	-40 to 200	-40 to 200
	°C	-40 to 93.3	-40 to 93.3	-40 to 93.3	-40 to 93.3	-40 to 93.3	-40 to 93.3	-40 to 93.3	-40 to 93.3	-40 to 93.3	-40 to 93.3
Materials of Construction		Body & Housing Aluminum Trim Zinc Plated Steel, Brass Diaphragm Nitrile on Dacron Fabric									
Hazardous Locations		Acceptable for use in Zones 1 and 2 for gas atmosphere; Groups IIA and IIB and Zones 21 and 22 for dust atmospheres									

Catalog Information

Catalog Number	208	<input type="checkbox"/>	<input type="checkbox"/>	<input type="checkbox"/>									
Ratio	1:1	1:2	1:3	2:1	3:1	1:4	4:1	1:5	5:1	1:6			
	1	2	3	4	5	6	7	8	9	10			
Pipe Size	1/4" NPT	3/8" NPT	1/2" NPT										
		2	3	4									
Options	Silicone Elastomers ²	Tapped Exhaust ¹	BSPP (Parallel) ⁵	By-Pass Valve ⁴	Viton Elastomers ¹	Non-Relieving ¹	BSPT (Tapered)	Negative Bias ^{1,3}					
	A	E	H	I	J	N	U	Y					

