



TECHNICAL DATA SHEET

Liferaft Lighting Systems R.INT2/R.EXT1 System

Daniamant design and manufacture all of our products in line with the relevant worldwide approvals, technical specifications, current legislation and International directives.

Our mission is to achieve World class performance through partnerships with our suppliers, customers and employees, providing products and services that enhance the safety and security of our customers.

Daniamant products cover 11 key areas:

- Lifejacket Lights
- Liferaft Lights
- Lifebuoy Lights
- Intrinsically Safe Lights
 - Special Lights
 - LED Flares
- Bridge Navigational Watch Alarm System (BNWAS)
 - Salinometers
 - Oil Level Alarm
 - Electronic Inclinator
- Agency for a range of world-renowned safety product brands (supplied to the Danish market)

MODEL	R.INT2 Internal Light	R.EXT1 Battery	R.EXT1 External Light
Part number Daniamant Version¹	1521: Vertical, 80 cm Cord length 1523: Vertical, 200 cm Cord length 1531: Horizontal, 50 cm Cord length	1621: Vertical, 80 cm Cord length 1623: Vertical, 380 cm Cord length 1631: Horizontal, 50 cm Cord length	1721: 75 cm Lead length 1731: 400 cm Lead length
Colour – Body	Orange		
Light – Output	Minimum 0.5 cd	Minimum 4.3 cd	
Light – Duration	Minimum 12 hours		
Light – Type	Steady	Flashing	
Material	ABS/Polycarbonate	ABS	ABS/Polycarbonate
Storage Temperature	-30° C to + 65° C		
Storage – Life	5 years		
Operating Temperature	-30° C to + 65° C		
Weight – nominal	55 g	132 g	1721: 81 g 1731: 272 g
Battery Type	Lithium Thionyl Dioxide	Lithium Sulphur Dioxide	No battery
Activation	Automatic during Raft activation. Can be switched separately		
Approvals – Classification Societies	SOLAS/MED/USCG		
Approvals – Country	See our web site for full list of Country approvals		

¹ These Part numbers cover the Daniamant versions. OEM versions of these lights will have different part numbers, please contact the relevant company for details.

Transport Specification

Transport Regulations are subject to change.

Packing Specification

To minimise shipping costs, these products are packed as follows:

The dimensions are:

R.INT2 Internal Light:

Box of 250 off: 40 x 20 x 60 cm

Box of 500 off: 40 x 40 x 60 cm

R.EXT1 Battery:

Box of 150 off: 40 x 20 x 60 cm

R.EXT1 External Light:

1721: Box of 250 off: 40 x 40 x 60 cm

1731: Box of 100 off: 40 x 40 x 60 cm

Approximate packed weights are:

R.INT2 Internal Light:

Box of 250 off: 17 kg

Box of 500 off: 31 kg

R.EXT1 Battery:

Box of 150 off: 23 kg

R.EXT1 External Light:

1721: Box of 250 off: 23 kg

1731: Box of 100 off: 30 kg

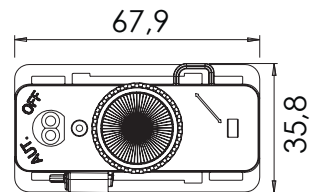
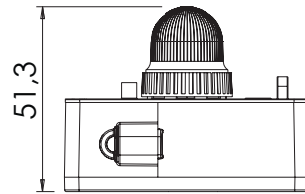

R.INT2 Internal Light

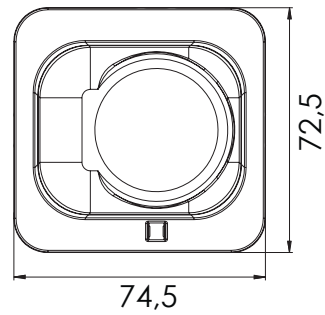
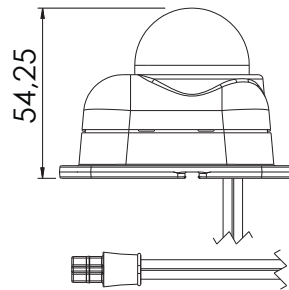

R.EXT1 External Light

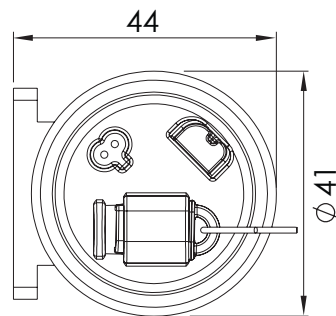
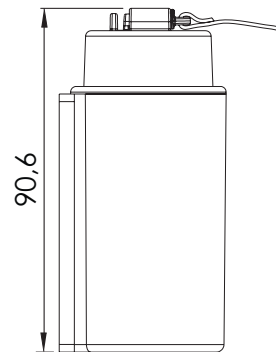

R.EXT1 Battery