

## CVS P37 LP Gas Reducing Regulator

The CVS Controls P37 Regulator is a non-relieving, pressure reducing regulator suitable for use in LP gas applications (Natural Gas and Propane). As well as standard compressed air applications.

### Features:

The balanced pintle design of the CVS P37 Regulator eliminates unwanted changes in the outlet pressure, due to inlet pressure variances.

Typical applications include:

- Compressed Air
- Actuators
- Valve Positioning
- Pneumatic Pressure Controllers
- Fuel Gas



CVS P37 LP Gas Regulator

## Specifications: CVS P37

---

Maximum Inlet Pressure: 400 PSIG (28 Bar)

Inlet/Outlet Port Size: 3/4", and 1/2"

Adjustments: T Handle Standard

Construction: Aluminum, Plated Steel,  
Buna-N, Brass, Zinc

Diaphragm Material: Nitrile/Polyester  
Fabric

Temperature Range: -40°F to 200°F (-40°C  
to 93.3°C)

Approximate Shipping Weight: 1.4lbs  
(0.63Kg)

Maximum Heat: Liquid Propane Gas  
Capacity in BTU/H: 1/2", 27,000,000; 3/4",  
30,000,000

Outlet Pressure Range: 0-60 PSIG\*

---

**\*Note:** The recommended operating range  
is between 10% and 100% of the  
adjustment range. Although the regulator  
may be shutoff, it is not intended for use in  
applications below 3 PSIG

---

Max Flow Capacity: (at max range)  
180 SCFM, Air Ps @140 PSIG for 1/2"  
200 SCFM, Air Ps @140 PSIG for 3/4"

## Installation:

---

It is recommended that only qualified or authorized personnel install and maintain the CVS P37 regulator.

Prior to installing, make sure there is no damage to the regulator, as well as foreign debris in all tubing or piping connections to the installation.

Ensure proper safety procedures are adhered to during installation and maintenance.

It is recommended that the CVS P37 Regulator be installed as close as possible to the supply instrument.

The CVS P37 may be installed at any angle without affecting performance.

Ensure the proper flow direction is used to prevent internal damage to the regulator. The flow direction is marked on the regulator body assembly as IN and OUT.

Apply a small amount of piping compound to the threads of the inlet and outlet piping.

Prior to startup, relieve all pressure on the spring by turning the T-Handle counter clockwise. Once supply pressure is applied to the regulator, test for leakage on all installation fittings.

To put the CVS P37 into service, slowly turn the T-Handle clockwise until the desired downstream pressure has been achieved. Tighten the locknut on the T-Handle to finalize installation.

Periodic inspection and maintenance may be required. If inspection reveals any issues, remove from service and repair or replace as required.

Contact a CVS Controls representative for more information.

**Note: The CVS P37 Regulator is a non-relieving regulator. The use of a relief valve is recommended in the installation. Additionally the P37 cannot exhaust excess pressure at the regulator assembly. It may be require to cycle downstream flow in order to achieve an accurate output pressure.**

## **Repair and Maintenance:**

Refer to the assembly drawing for part identification to assist with the following instructions.

Disassembly:

1. Remove all spring pressure by turning the T-Handle (1) counter clockwise.



2. Remove Qty. 6 , screws (18) holding the Spring Case (2) and the Body Assembly (7) together. Lift off the spring case, and remove the Spring (4), and Upper Spring Seat (3)



3. Unscrew the Diaphragm Assembly from the Driving Pintle (9), by first removing the Bottom Plug (12), O-Ring (13), and Pintle Spring (11). Holding the Piston Assembly (10), loosen the diaphragm assembly using a  $\frac{3}{4}$ " wrench or similar. Lift out the diaphragm assembly from the regulator body.



Inspect all components for visible damage and replace or repair as necessary.  
Reassemble in reverse order.

# Dimensional Data: Inches

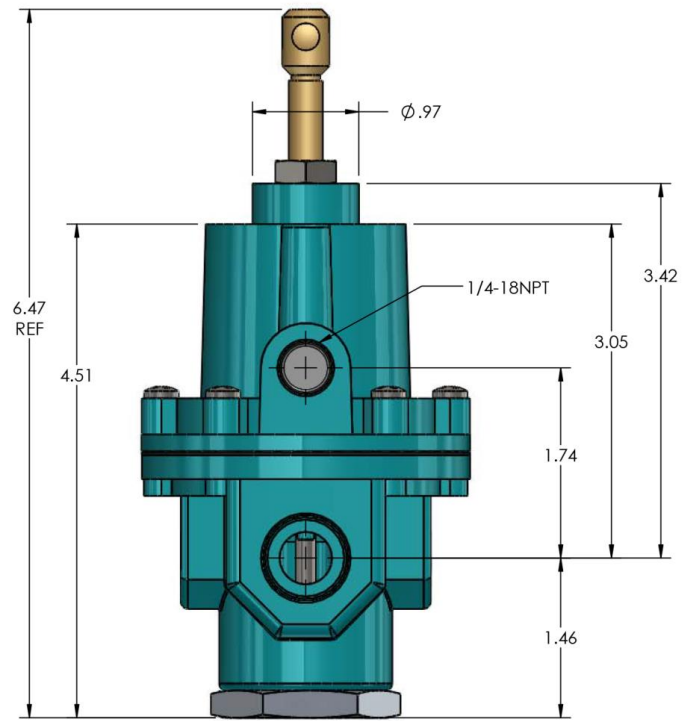
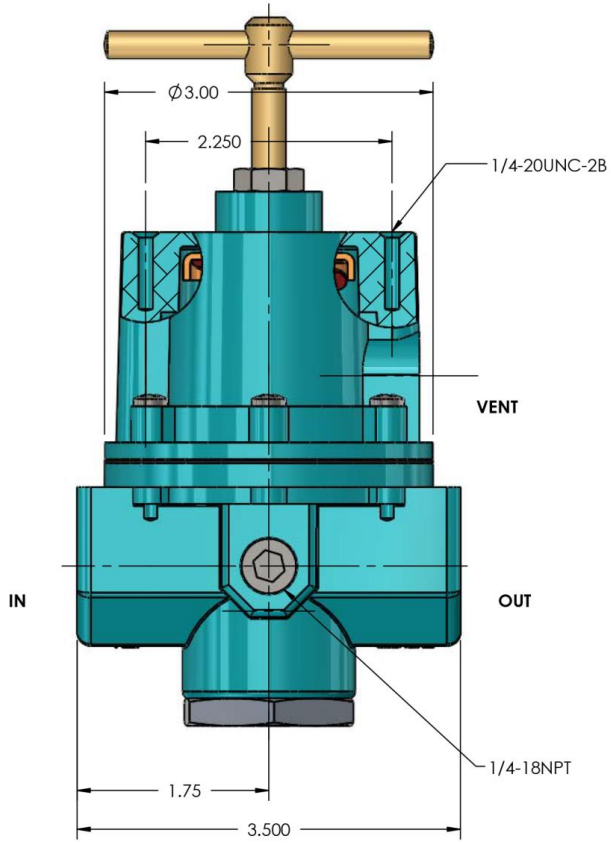

## CVS P37 Assembly:

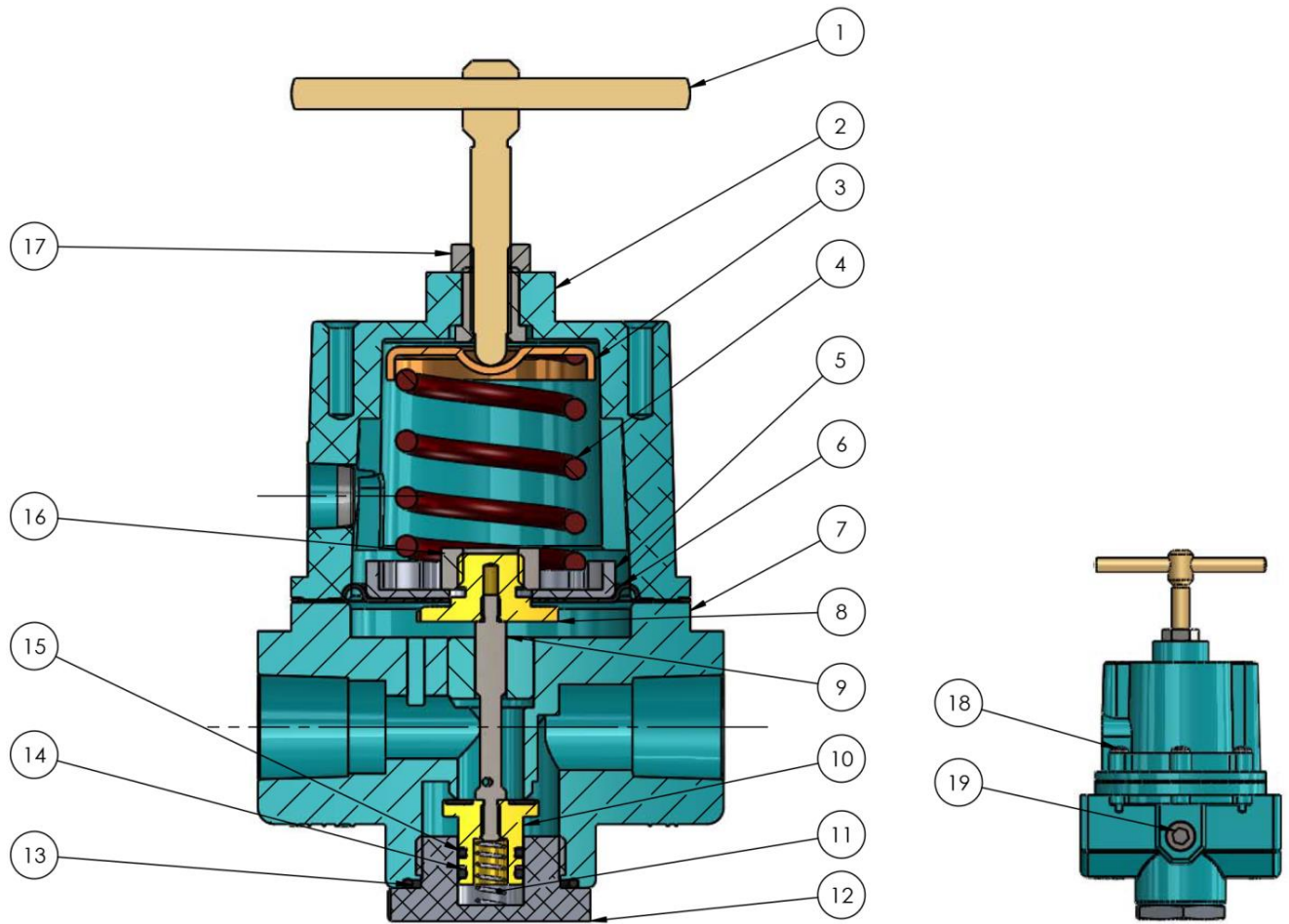

Item	Part Number	Description	Item	Part Number	Description
1	CVS P3700001	Adjusting Screw Assembly	11	CVS P3700011	Pintle Spring
2	CVS P3700002	Spring Case Assembly	12	CVS P3700012	Bottom Plug
3	CVS P3700003	Upper Seat Spring	13	CVS P3700013	o-ring, #025
4	CVS P3700004	Spring	14	CVS P3700014	o-ring, #012
5	CVS P3700005	Lower Seat Spring	15	CVS P3700015	Quad Ring, #012
6	CVS P3700006	Diaphragm	16	CVS P3700016	Hex Nut, 1/2-13
7	CVS P3700007	Body Assembly, 1/2-14 Port	17	CVS P3700017	Hex Nut, 5/16-24UNF
	CVS P3700107	Body Assembly, 3/4-14 Port	18	CVS P3700018	RH Screw, 8x32, .87" long, (6ea)
8	CVS P3700008	Diaphragm Screw	19	CVS P3700019	1/4" NPT Plug, (2ea)
9	CVS P3700009	Driving Pintle			
10	CVS P3700010	Piston Assembly			

Notes:

## Notes:

CVS Controls Ltd. strives for the highest levels of quality and accuracy. The information included in this publication is presented for informational purposes only. CVS Controls Ltd. reserves the right to modify or change, and improve design, process, and specifications without written notice. Under no circumstance is the information contained to be interpreted to be a guarantee/warranty with regard to our products or services, applicability or use.

Selection, use and maintenance are the sole responsibility of the end user and purchaser. CVS Controls assumes no liability for the selection use and maintenance of any product.