

CVS 1000R Electro-Pneumatic Rotary Positioner

INTRODUCTION

Thank you for choosing the YT-1000R. Each product is fully inspected after production to offer you the highest quality. In order to fully utilize the product, we strongly recommend users to read this manual carefully.

- The manual can be changed or revised without any prior notice. Any changes in the product's specification, structure and/or any components may not result an immediate revised version of the manual.
- The manual should not be duplicated or reproduced for any purpose without the approval of CVS Controls Ltd.

MANUFACTURER WARRANTY

- For safety, it is imperative to follow instructions in the manual. The manufacturer is not liable for any damages caused by the users negligence.
- The manufacturer is not liable for any damages or accidents as a result of alterations or modifications made to the product or parts. If alterations or modifications are required, please contact CVS Controls Ltd.
- The manufacturer warrants the product from the original date of purchase for one (1) year, except as otherwise stated.
- The manufacturer warranty will be considered void should the product be subjected to abuse, faulty installation, lack of reasonable care, repair or service in any way, that is not contemplated in the documentation of the product, or if the model or serial number has been altered, tampered with, defaced, or removed; damages that occur in shipment, due to the act of God, failure due to power surge, and cosmetic damage. Improper or incorrectly performed maintenance also voids the Limited Warranty.



PRODUCT DESCRIPTION

Main Features and Functions

- It is designed for high durability and performance in high vibration environments.
- Proven Durability.
- Short and accurate response time.
- Simple part change can set a 1/2 Split Range.
- Economical due to less air-consumption.
- Direct/Reverse action can be easily set.
- Simple zero and span adjustment process.
- Easy feedback connection.

Operation Logic

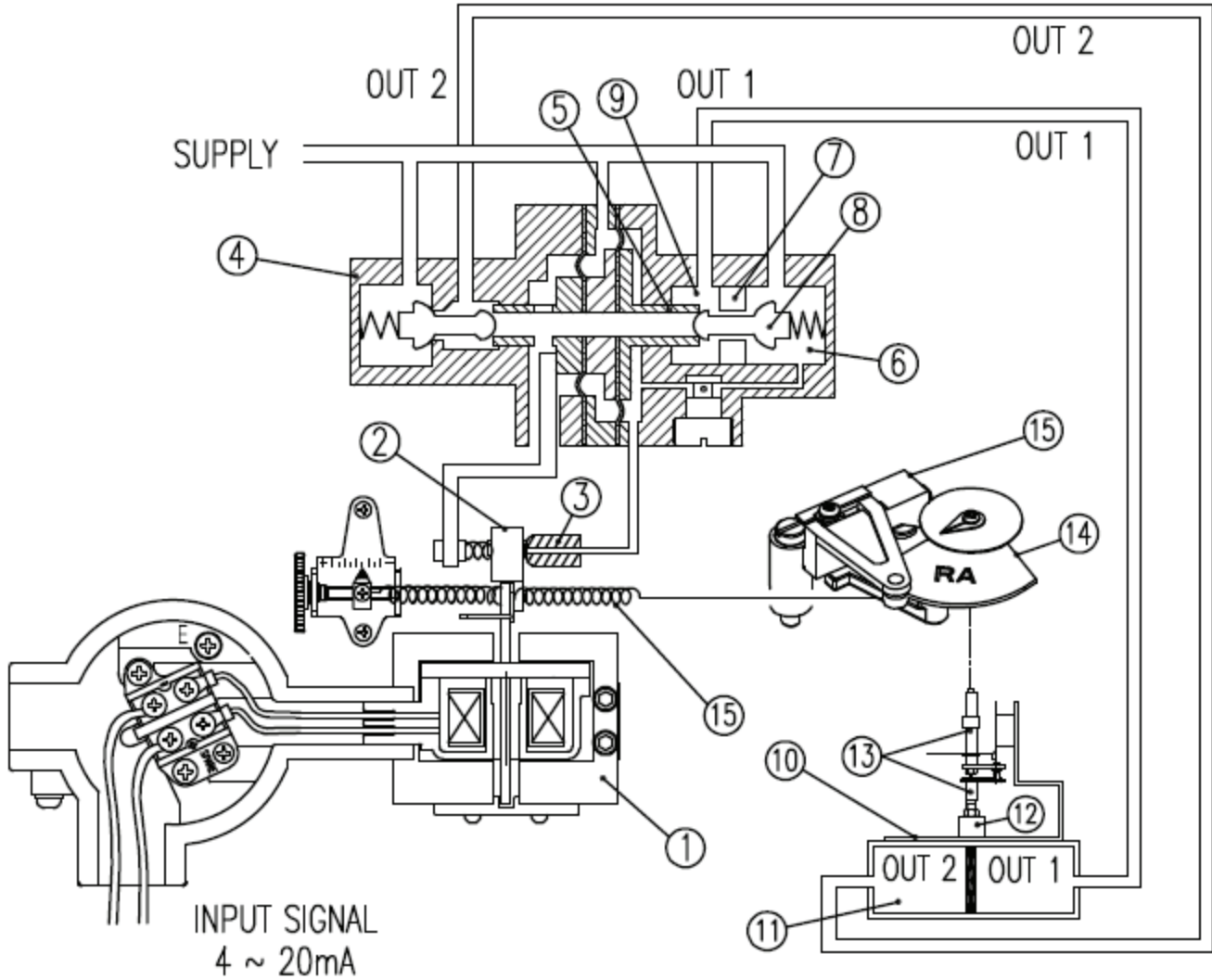

As the input current signal is increased, the **flapper (2)** gets pushed by the force of the **torque-motor (1)**. As the gap between the **flapper (2)** and the **nozzle (3)** increases, air pressure bleeds from the **pilot valve (4)** and the **upper spool (5)**. As a result, the **spool (5)** rises and simultaneously opens the **seat (7)**. This allows air pressure to discharge through port **OUT1** to the **actuator (10)**. As the actuator (10) rotates, the **feedback lever (13)** rotates the **cam (14)** in the same direction exerting force on the **feedback spring (16)**. At the point of balanced force exerted by the input signal and the **feedback spring (16)**, the gap between the **flapper (2)** and the **nozzle (3)** will decrease, stopping the movement to the **actuator (10)**.

Specification

CATEGORY	YT - 1000R	
	Single	Double
Input Signal	4 ~ 20mA DC *1	
Impedance	250±15Ω	
Supply Pressure	1.4 ~ 7.0kgf/cm ² (20 ~ 100psi) (140 ~700 kPa)	
Stroke	0 ~ 90° *2	
Air Connection	1/4" NPT	
Gauge Connection	1/8" NPT	
Conduit Entry	1/2" NPT	
Explosion Proof	CSA: Class 1, Zone 1, Group IIB, T5	
Protection	IP66	
Operating Temperature	-40 ~ 60°C (-40~140°F)	
Linearity	±1.0% F.S	
Hysteresis	1.0% F.S	
Sensitivity	±0.2% F.S ±0.5% F.S	
Repeatability	±0.5% F.S	
Air Consumption	3LPM (Sup=1.4kgf/cm ² , 20psi)	
Flow Capacity	80LPM (Sup=1.4kgf/cm ² , 20psi)	
Material	Aluminum Diecasting	
Weight	2.7 kg (6.1 lbs)	

* 1: For split range, recalibrate using zero and span.

* 2: For inquiries regarding strokes under 10mm or above 150mm, please contact CVS Controls Ltd.

Parts and Assembly

*dome not shown

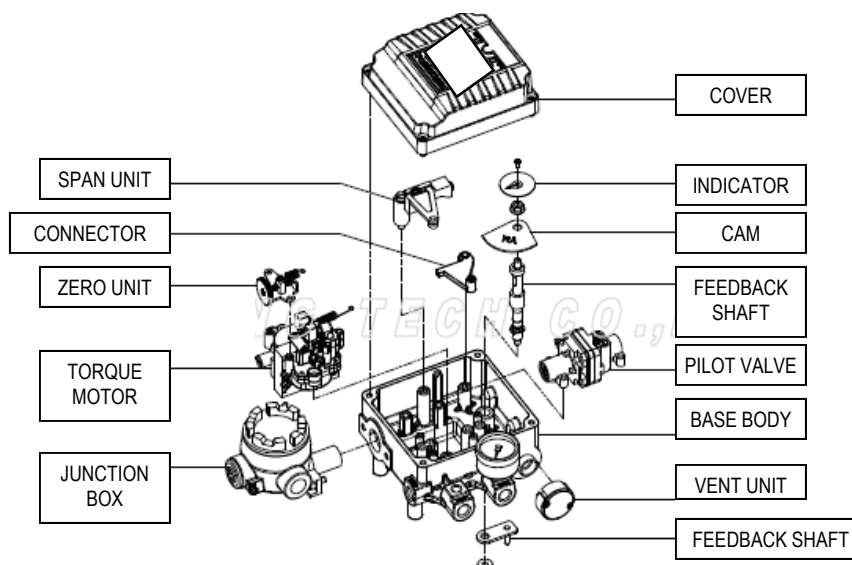

Dimensions

*dome not pictured

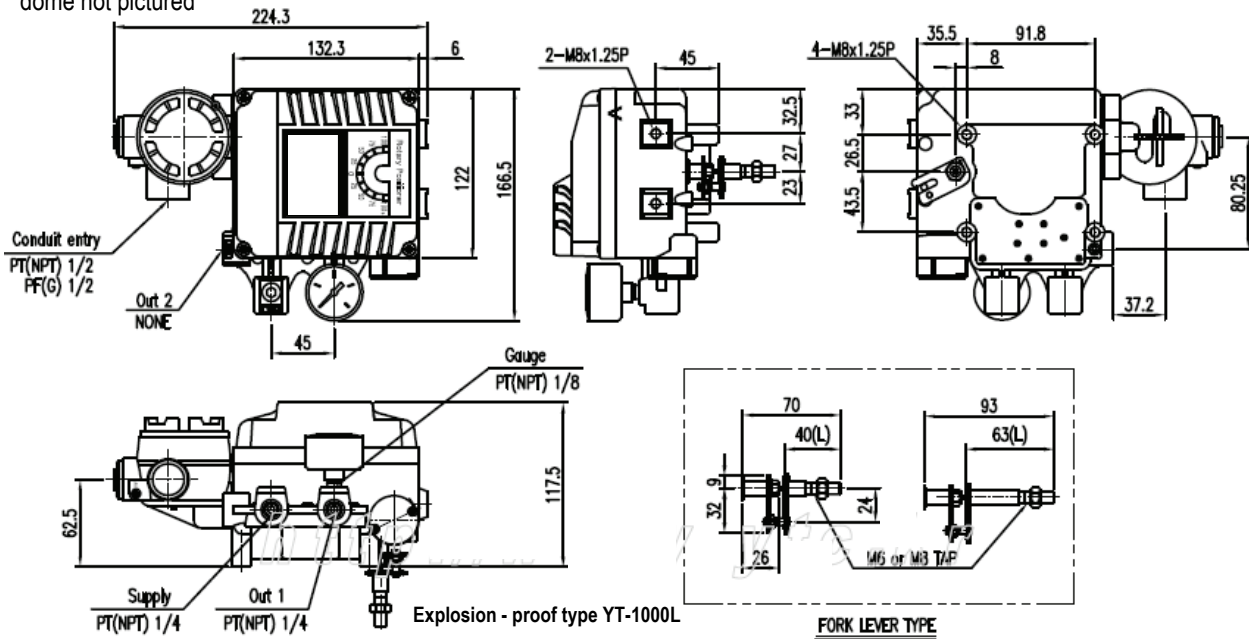

INSTALLATION

Safety Warning

When installing the positioner, please ensure you read and follow the safety instructions.

- All input and supply pressure to valve, actuator, and other related devices must be turned off.
- Use the bypass valve or other equipment to avoid an entire system “shut down”.
- Make sure there is no remaining pressure in the actuator.

Before installation, be sure to check for the following installation components:

1. YT-1000R main body
2. Feedback lever and lever spring
3. Flange nut (bottom side of YT-1000R)
4. 4 pcs. of hexagon head bolts (M8 X 1.25P)
5. 4 pcs. of M8 washer

YT-1000R Installation

YT-1000R should be installed on a rotary motion valve such as a ball valve or butterfly valve using a spring return type diaphragm or piston actuator.

Installation Steps:

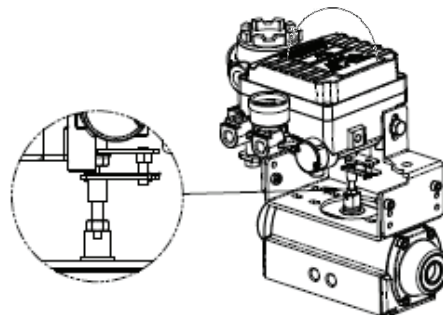

<Figure 2: Using Fork Type Lever>

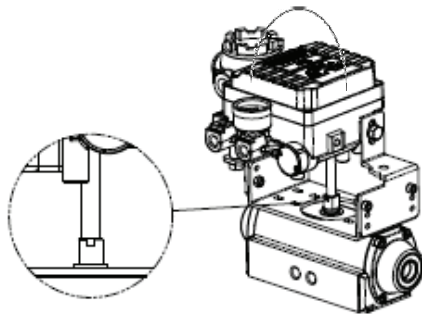

<Figure 3: Using NAMUR Shaft>

Using Brackets to Install:

YT-1000R is provided with a standard bracket. This bracket contains three parts, and brackets can be used for both the fork type lever and the NAMUR shaft.

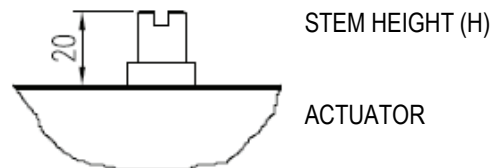

<Figure 5: Measuring Stem Height (H)>

2. Attach bracketed YT-1000R to the actuator by using a hexagon-headed and wrench bolts. The size of the bracket hole is 6mm. When tightening the bolts, use the spring washer or similar washer for firm attachment to the actuator, so the YT-1000R will not shake by vibration or other impact. The direction of the bracket is different from the operating condition, but normally, the positioner is installed as shown in (Figure 6.)

3. Set rotation position of the actuator stem at zero point, "0%". For a single type of actuator, it is easy to

Bracket Assembly Method

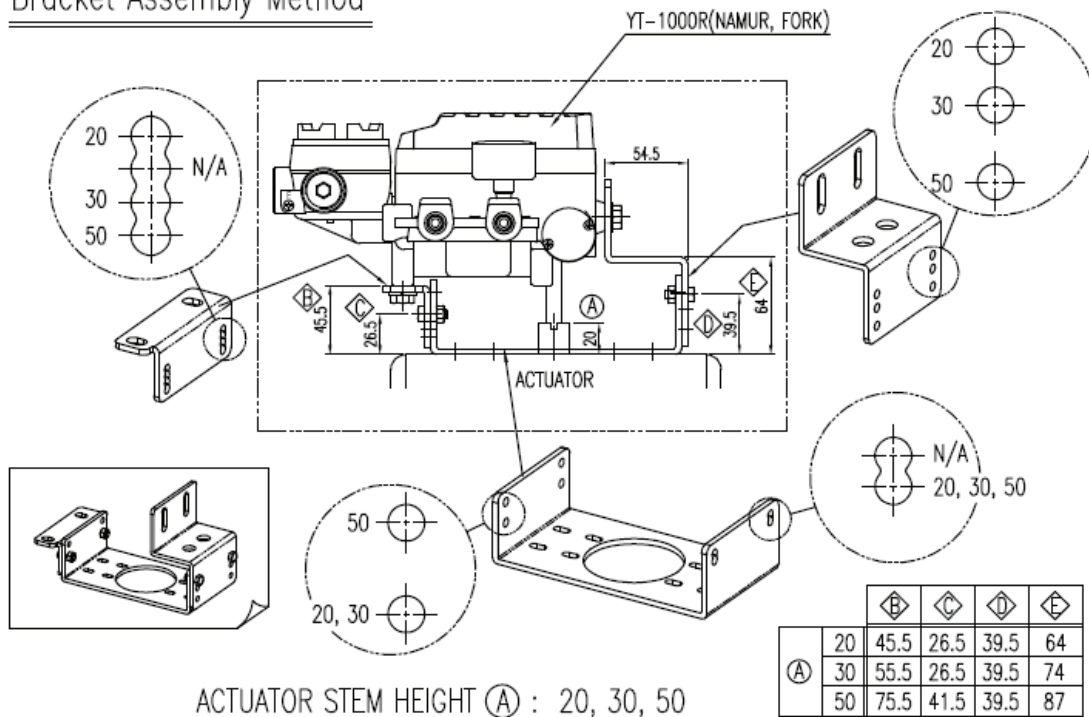

ACTUATOR STEM HEIGHT (A) : 20, 30, 50

<Figure 4: Assembly Method by stem height 'H'>

1. In general, the height of an actuator (H) is 20, 30, or 50mm. Please check using actuator stem height and assemble bracket according to (figure 4.)

check zero point because the actuator stem is positioned at zero point when there is no supply pressure. If a double acting actuator is used, check the actuator's stem rotation direction (clockwise or counter-clockwise) by supplying pressure.

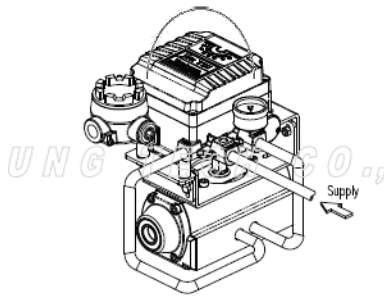

<Figure 6>

4. Install the fork lever as shown in Figure 7 after setting the actuator stem at zero point. Check the direction of the actuator stem, clockwise or counter-clockwise. Installation angle of the fork lever should be 45 degrees based on the linear shaft. For NAMUR shaft, the angle does not matter. (Figure 7)

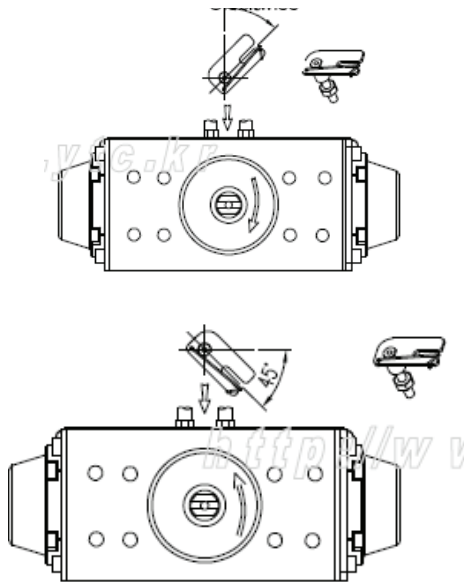

5. After setting the fork lever position, lock the nut which is assembled to the bottom of the fork lever. Make sure to set the upper height of the fork lever between 6-11mm. Lower than the upper bracket height. (Figure 8)

6. Attach the YT-1000R to the bracket. Fix the clamping pin on the main shaft's center of the YT-1000R and insert the connection bar into the fork lever slot so that it can be locked to the fork lever spring. This sets the alignment of the main shaft of the YT-1000R and center of the actuator stem.

WARNING: Incorrect alignment of the main shaft and the actuator stem lowers YT-1000R's durability, because too much force will be on the main shaft of the YT-1000R. (Figure 9)

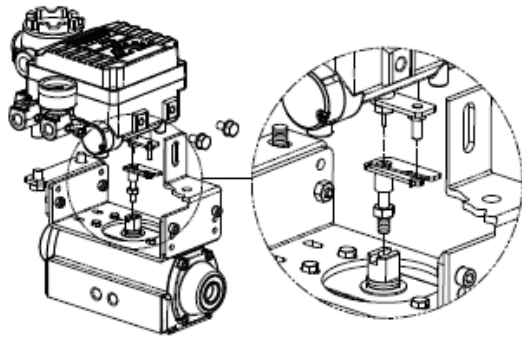

<Figure 9>

7. Tighten YT-1000R base and the bracket with hexagon-headed bolts and plated washer. It is recommended to tighten four bolts after checking YT-1000R's position.

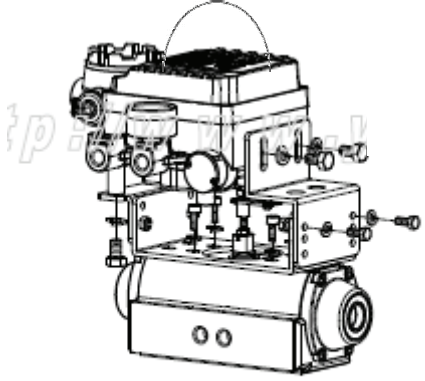

<Figure 10>

PIPING CONNECTION

NOTE:

- To avoid moisture, oil, or dust from entering the product, please carefully select the supply pressure compressor.
- It is recommended to attach the air filter prior to the supply port of the YT-1000R.

Supply Pressure Condition

1. Dry air with at least 10°C lower than ambient temperature.
2. Keep away from dusty air. Filter can only sort 5 micron or larger.
3. Avoid oil.
4. Comply with ANSI/ISA-57.3 1975(R1981).
5. not to be used beyond the range of 1.4-7 kgf/cm² (140 - 700 kPa). (20 ~ 100 psi)
6. Set air filter regulator's supplied pressure 10% higher than actuator's spring range pressure.

Pipe Condition

1. Make sure inside of pipe is empty.
2. Do not use pipeline that is squeezed or has holes.
3. To maintain flow rate, use the pipeline that has more than 6mm inner diameter.
4. Do not use an extremely long pipeline system. It may affect flow rate due to the friction inside the pipeline.

Piping Connection with Actuator

YT-1000 series single acting type is set out to use OUT1 port. OUT1 port should be connected with the supply pressure port from the actuator when using a single acting type spring return actuator.

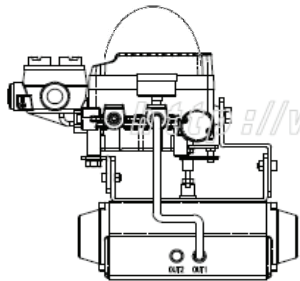

<Figure 11>

Double Acting Actuator:

For YT-1000R series double acting type, when inputting current signal, supply pressure is out from OUT1. Please refer to Figure 12.

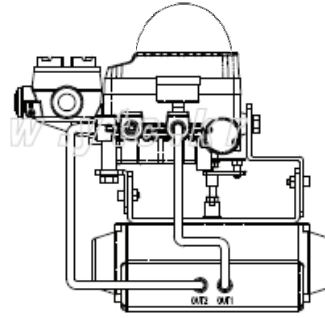

<Figure 12>

POWER CONNECTION - EXPLOSION PROOF TYPE

Connection - Connection Port

- Connection port size is 1/2" NPT.

NOTE: REFER TO THE CANADIAN ELECTRICAL CODE FOR HAZARDOUS WIRING.

Connection Power

1. Open terminal box cover.
2. Locate the poles and connect them properly. Make sure the connections are secure.
3. Close the terminal box cover. **(Figure16)**

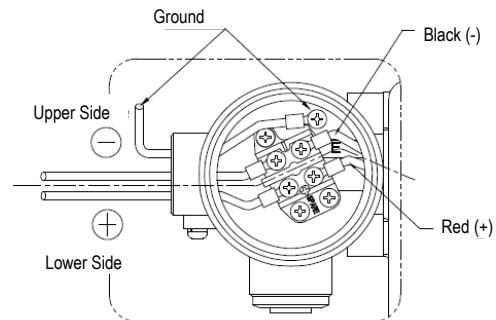

Connection - Ground

1. Open positioner's body cover.
2. Locate the poles and connect them properly. **(Figure 17)**

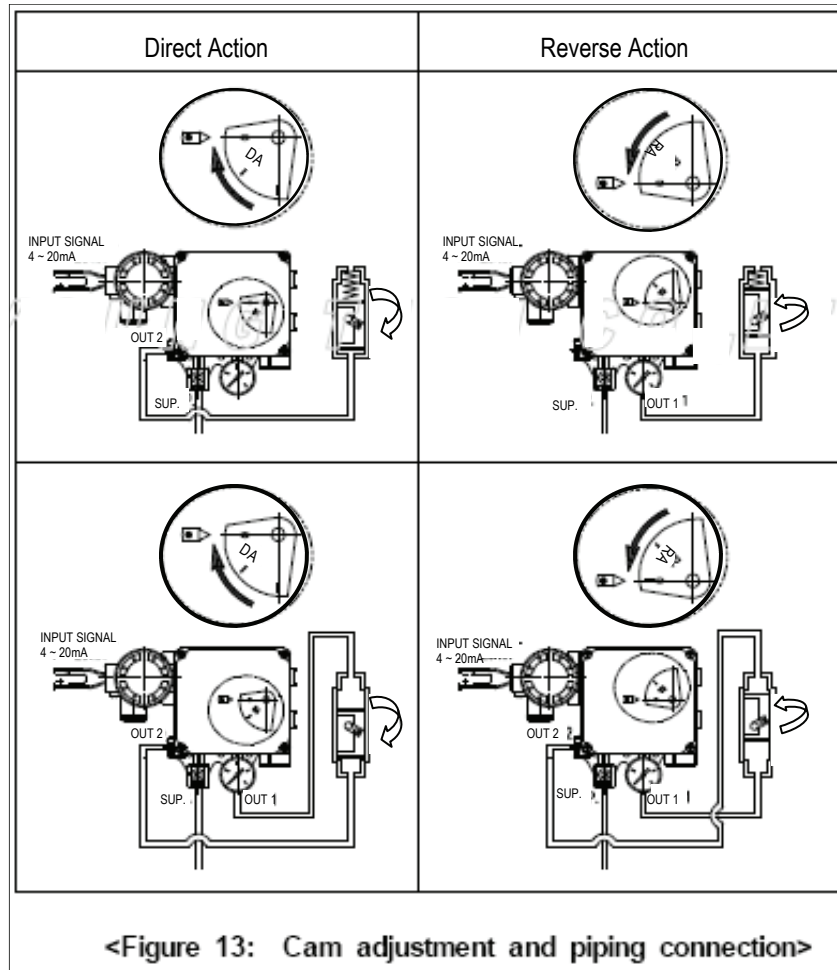

ADJUSTMENT

Adjustment - Zero Point

1. Set supply signal at 4mA or 20mA and rotate adjuster clockwise or counter-clockwise to adjust actuator's initial point. When setting initial point, the specification of valve and system must be taken into account. Please refer to Figure 18 for increase/decrease of the zero point.
2. When single acting actuator with spring is used, please check if the pressure level, which is indicated on the positioner, is the same as the supplied pressure level. **(Figure 18)**

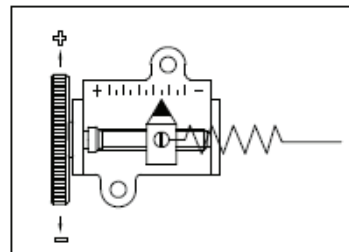

Adjustment - Span

1. After setting zero, supply 20mA or 4mA of signal. Check the actuator's stroke. If the stroke is too low, adjust the span towards the (+) direction. If the stroke point is too high, adjust the span towards the (-) direction.

(Figure 19)

2. Changing span points affects the zero point setting, so the zero setting must be set again. After setting zero point, confirm the span point. This step must be repeated until both points are properly set.

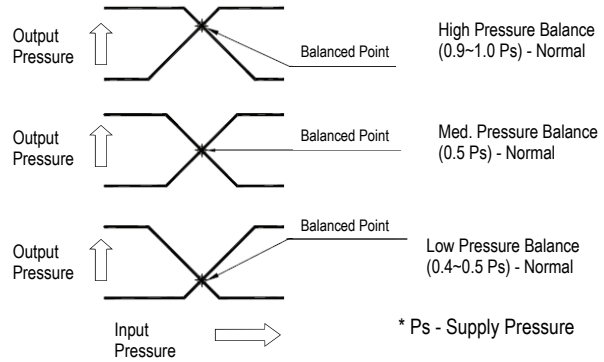
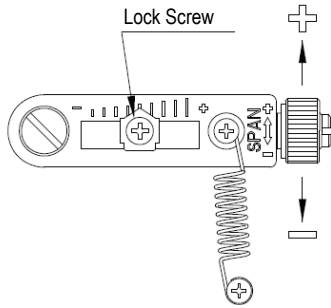

Adjustment - A/M Switch (Auto/Manual)

1. A/M switch adjusts the valve operation to automatic or manual.
2. When produced, YT-1000L is set at "A(Automatic)". If user prefers the positioned setting as "M(Manual)", the setting can be changed by turning the switch counter-clockwise. **(Figure 20)**

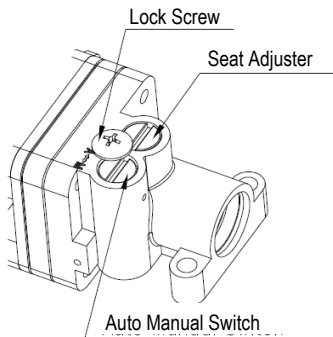

3. If it is set as "M(Manual)", the air pressure will be supplied to the actuator directly. Always set back to "A(Automatic)" after setting change.
4. If OUT2 in a single acting actuator or double acting actuator is used, A/M switch will not operate.

Adjustment - Seat Adjuster

1. Seat adjustment is set according to the customers request before the positioner is delivered. Please do not adjust the seat adjuster.
2. Seat adjuster is always used for double acting actuators and adjusted when the pressure balance point must be changed. Please do not touch the seat adjuster, because it can affect the positioner's performance.

Adjustment - Orifice

1. If the size of the actuator is too small relative to the flow rate, the positioner can have hunting. In order to avoid hunting, orifice can be used. There are three types of orifice.
2. Remove the o-ring from OUT1 and OUT2 port and insert appropriate orifice. After inserting orifice, replace the o-ring. Make sure there are not any substances entering into the port. **(Figure 22)**
3. If hunting persists after inserting the orifice, please contact CVS Controls Ltd.

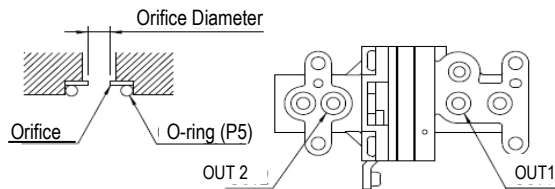

Actuator Size	Orifice Size	Suffix Symbol
90 cm ³ less	O 1	1
90 - 180 cm ³	O 2	2
180 cm ³ more	none	3

MAINTENANCE - PILOT VALVE

Maintenance should be performed on the Pilot Valve Relay at least once a year. When disassembling the pilot valve relay please make sure not to lose the o-ring or stabilizer spring. **(Figure 23)**

1. Remove stopper bolts.
2. Unlock the Auto/Manual switch.
3. Remove any blockage from the port and/or orifice.

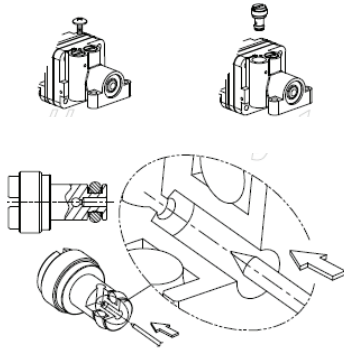

TROUBLESHOOTING

► Positioner does not respond to the input signal.

1. Check supply pressure level. The lever must be at least 1.4 kgf/cm². For a spring return type actuator, the supply pressure level has to be larger than the spring's specification.
2. Check if the input signal is properly supplied to the positioner. The signal should be 4~20mA DC.
3. Check if zero point or span point is properly set.
4. Check if the positioners nozzle has been blocked. Also, check if the pressure is supplied to the positioner and the pressure is being exhausted through the nozzle. If the nozzle has been blocked by any substances, please send the product for repair.
5. Check if the feedback lever has been installed properly.

► The pressure of OUT1 reaches exhausting pressure level and does not decrease.

1. Check A/M Switch. If the switch has been damaged, replace the switch or pilot relay valve.
2. Check for a gap or damages between the nozzle and the flapper. If damaged, please contact CVS Controls Ltd.

► The pressure is exhausted only by the A/M switch.

1. Check if the positioners nozzle has been blocked. Also, check if the pressure is supplied to the positioner and that the pressure is being exhausted through the nozzle. If the nozzle has been blocked by any substances, please contact CVS Controls Ltd.

► Hunting occurs

1. Check if the safety spring has been displaced. (Next to pilot relay valve)
2. Check if the size of the actuator is too small. If so, insert an orifice in order to reduce the pressure flow rate.
3. Check if there is any friction between the valve and the actuator. If so, increase the actuator's size or reduce the friction level.

► Actuator only operates by on/off

1. Check actuator and positioner's acting type. Air pressure exhausts from YT-1000R's OUT1 port as the input signal level increases. Therefore it is standard to connect to OUT1 port when a single actuator is used. Make sure the span adjustment is properly set according to the valve system.

► Linearity is too low

1. Check if the positioner is properly positioned. Especially that the feedback lever is parallel to the ground at 50% point.
2. Check if zero and span point have been properly adjusted. If either one of the values is being adjusted, another one must be adjusted as well.
3. Check if supply air pressure level is stable from the regulator. If the level is unstable, the regulator must be replaced.

► Hysteresis is too low

1. In case of a double acting actuator, check if seat adjustment has been properly performed. Please contact CVS for any further inquiries regarding the seat adjustment.
2. Backlash can occur when the feedback lever and lever spring loosen. To avoid backlash, please adjust the lever spring.
3. Check if the connection bar to the feedback lever is tightly fastened.

NOTES
