

VERSATILE LIMITSWITCH



PROFIBUS[®]
DEVICENET[®]
CANOPEN[®]
ASI[®]



DNLF6-Explosion Proof Hermetically Sealed Prox Switch

ROTEX Cobra Switch



FEATURES

- Explosion proof to I, IIA, IIB, and IIC
- Enclosure certified to UL 1203 & UL508, File No. 246615
- Switch Box conforms to Ex D IIC, T6 highest level of safety
- ATEX certified by CESI, Italy, Cert No. CESI 05 ATEX017
- Aluminum die cast enclosure, powder coated for superior corrosion resistance
- Weather proof enclosure to IP67
- Polycarbonate Dome, Shatterproof
- Red and Yellow Indicator
- Color coded cams easy to identify, easy to set
- Special circuit board eliminates internal wiring
- Circuit board laminated for complete corrosion protection
- Solenoid termination inside the switch box is standard
- Serrated cams locked together ensures adjusted settings secured against any vibration
- Two conduit entries provided as standard
- Conduit entry options 1/2" NPT, 3/4" NPT, M20X1.5
- Temperature 4°F to 146°F
- Bracket available as option

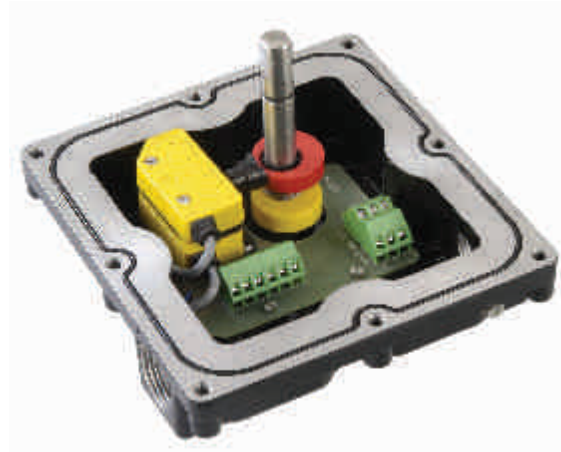

ORDERING OPTIONS

Series	Switch	Qty. Switches	Conduit Entry	Body/Cover	Bracket	Certificates
DNLF		1	4R 1/2" NPT	B Aluminum-Black		U CU _L , UL _L
		2	6R 3/4" NPT	Y Aluminum-Yellow		C CE
			3M M20X1.5	L Aluminum-Blue		A ATEX
				B5 CF8M Stainless Steel		

CODE	MAKE	MODEL	RATING
6A	Hermetic Switch Inc.	COBRA	2Amps, 220V AC/DC, 50Hz/60Hz, NO/NC
16A	Hermetic Switch Inc.	COBRA GOLD	0-48 VDC, up to 100mA 0-220 VAC, 20 mA

Refer to Bracket Selection Page

ORDERING EXAMPLE

- DNLF-6A2-6R-B-BKS1-A
- Explosion proof box with (2) hermetically sealed switches, 3/4" conduit entries, black enclosure, with stainless steel bracket suitable for 80X30 tapping and for 20mm pinion height. With ATEX certificate

VERSATILE LIMITSWITCH



DNLF6-Explosion Proof Hermetically Sealed Prox Switch

ROTEX Cobra Switch

MATERIAL OF CONSTRUCTION

23	CIRCUIT BOARD	1	-
22	'O'RING	1	NBR
21	PHILIPS HEAD SCREW	4	STAINLESS STEEL
20	SCREW FOR EARTHING	2	STAINLESS STEEL
19	MOUNTING PLATE	1	M.S.
18	'O'RING	2	NBR
17	CAM INSERT	2	POLYAMIDE
16	SPRING	1	STAINLESS STEEL
15	'E' TYPE CIRCLIP	1	SPRING STEEL
14	NON FALLING SCREW	8	STAINLESS STEEL
13	SCREW FOR CONN. STRIP	2	STAINLESS STEEL
12	SCREW FOR REEDSWITCH	2	STAINLESS STEEL
11	GASKET	1	NBR
10	INDICATOR COVER	1	POLYCARBONATE
9	INDICATOR	1	ABS PLASTIC
8	CONNECTOR STRIP-6WAY	1	POLYIMIDE
7	REED SWITCH ASSEMBLY	2	-
6	SPRING DOWEL	2	SPRING STEEL
5	SHAFT	1	STAINLESS STEEL
4	CAM-LOCK	2	POM
3	CAM	2	POLYCAMIDE
2	COVER	1	ALUMINUM ALLOY LM-6
1	HOUSING	1	ALUMINUM ALLOY LM-6
S.NO.	DESCRIPTION	QTY.	MATERIAL

CROSS SECTION

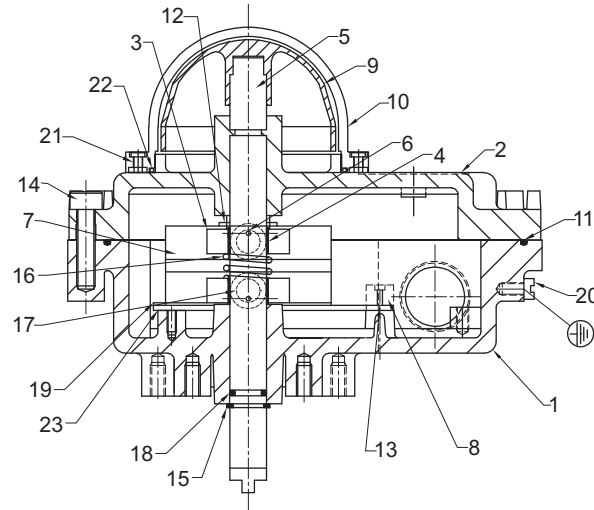

DIMENSION DETAILS

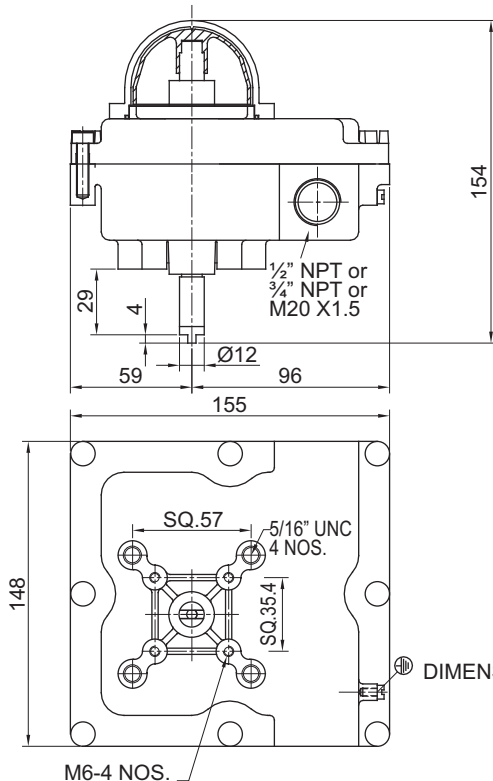

WIRING DIAGRAM

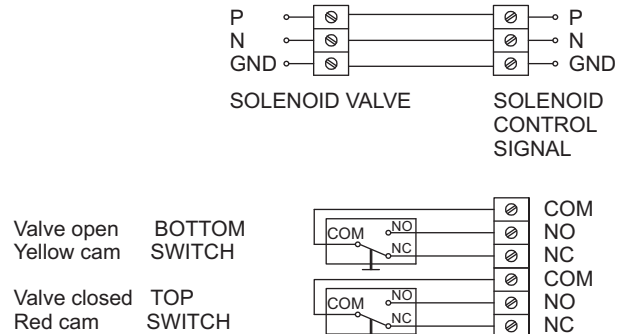

DIMENSION 'X' OPTIONS : 1/2" NPT
 3/4" NPT
 M20X1.5



ROTEX
INFINITY ACTUATORS