

CVS Controls Ltd.

Series BTE Choke Valves

The CVS Controls Series BTE is an inline choke valve suitable for a wide variety of applications throughout the oil and gas sector.

Typical installations include: Severe Service applications with high pressure drop specifications.

Field Serviceable. May be actuated with either pneumatic, hydraulic or electric actuators.

Available in 2 inch, Ring type Joint (RTJ) Class 2500 and 3 inch RTJ Weld Neck Class 2500 end connection.

Standard configuration for the CVS Series BTE is A487 Cast Steel Body, Tungsten Carbide Discs, High Saturated Nitrile (HSN) sealing components for sour service. NACE Compliant is standard. Erosion resistant.



3 Inch CVS Series BTE Choke Valve with
CVS 140SR Rack and Pinion Actuator and
CVS 3400 Smart Positioner

SPECIFICATIONS – 2 Inch Class 2500 RTJ

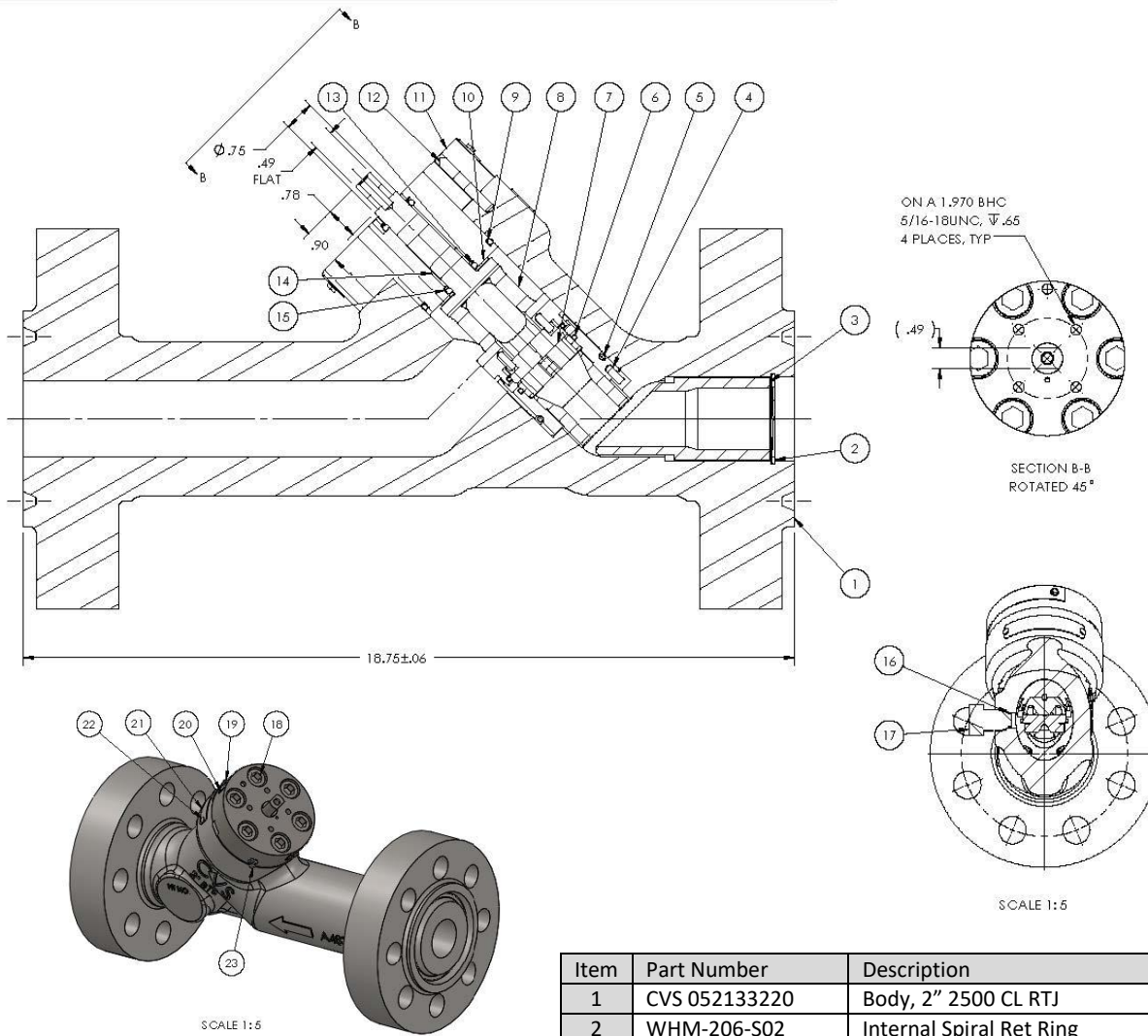

Item	Part Number	Description	Qty
1	CVS 052133220	Body, 2" 2500 CL RTJ	1
2	WHM-206-S02	Internal Spiral Ret Ring	1
3	CVS 051976400	Body Sleeve	1
4	CVS 052070434	Wear Sleeve Assembly	1
5	CVS WWB226P41	O-Ring #226	1
6	CVS WWB132P41	O-Ring #132	2
7	CVS 051961340	Disk, 61/64 Pie	2
8	CVS 051961524	Turning Fork Assembly	1
9	CVS WWB227P41	O-Ring #227	1
10	CVS 051969430	Thrust Washer	1
11	CVS 052120830	Bonnet	1
12	CVS 051961000	Indicator Pin	1
13	CVS WWB210P41	O-Ring #210	2
14	CVS GSI-1214-08	Sleeve Bearing	
15	CVS WWB210T10	Backup Ring	1
16	CVS WWB014P41	O-Ring #014	1
17	CVS 051988780	Pressure Relief Plug	1
18	CVS WWG11M1HN	Hex Head, 5/8-11UNC X 1-1/2"	6
19	CVS WWGG0618F	Hex Self Tap #6X32, 1/4" Long	2
20	CVS 051961606	Indicator Band, 61/64"	1
21	CVS 05196161N	Name Tag	1
22	CVS 1A368228982	Drive Screw	2
23	CVS WWW00C000	Grease Fitting	1

SPECIFICATIONS – 3 Inch Class 2500 RTJ Weld Neck

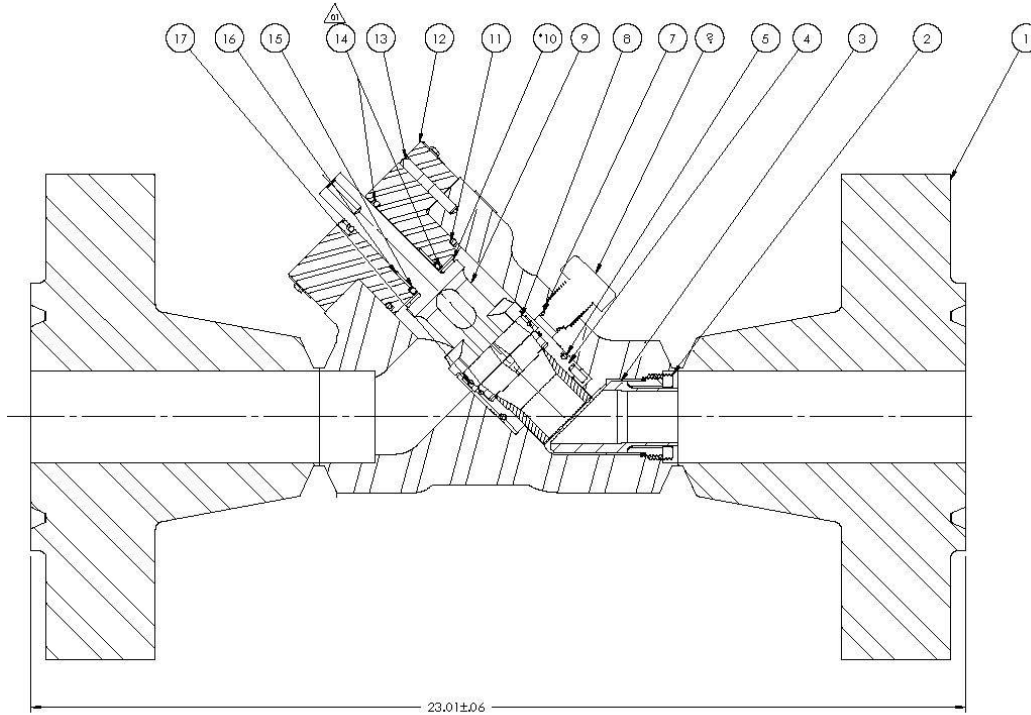

Item	Part Number	Description	Qty
1	CVS 051994725	Body Assembly	1
2	CVS 052131320	Body Sleeve Retainer	1
3	CVS 051975100	Body Sleeve	1
4	CVS 052118534	Wear Sleeve, Assembly	1
5	CVS WWB226P41	O-Ring #226	1
6	CVS 0519988780	Pressure Relief Plug	1
7	CVS WWB014P41	O-Ring #014	1
8	CVS 051983640	Disk, 72/64" Pie	2
9	CVS 052118635	Turning Fork, Assembly	1
10	CVS 051969430	Thrust Washer	1
11	CVS WWB227P41	O-Ring #227	1
12	CVS 052120830	Bonnet	1
13	CVS 051961000	Indicator Pin	1
14	CVS WWB210P41	O-Ring #210	2
15	CVS WWB210T10	Backup Ring	1
16	CVS GSI-1214-08	Sleeve Bearing	
17	CVS WWB033P41	O-Ring #033	2
18	CVS 051961613	Indicator Band, 72/64"	1
19	CVS WWGG0618F	Hex Self Tap #6X32, 1/4" Long	2
20	CVS WWG11M1HN	Hex Head, 5/8-11UNC X 1-1/2"	6
21	CVS 05196161N	Name Tag	1
22	CVS 1A368228982	Drive Screw, 302SST	2
23	CVS WWW00C000	Grease Fitting, 1/8-27	1

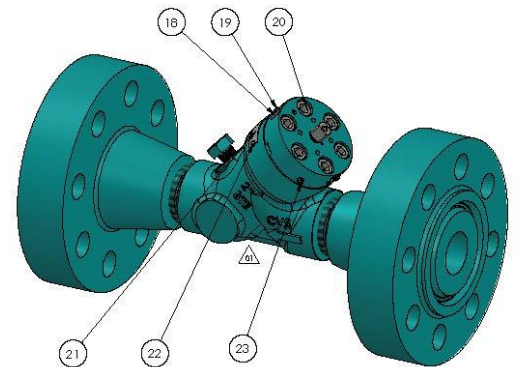

SPECIFICATIONS

Material – Standard* NACE	
Body	A487 Cast Steel
Seals	High Saturated Nitrile - HSN
Turning Fork	17-4 SST
Discs	Tungsten Carbide
Wear Sleeve	Standard w/carbide insert
*Additional materials may be available upon request. Contact CVS Controls Ltd. for more information.	

CVS BTE Class 2500 API Torque Requirements		
Differential Pressure	In-Lbs	Ft-Lbs
1000 psi	408	34
2000 psi	604	50
3000 psi	799	67
4000 psi	994	83
5000 psi	1189	99

CVS Controls Ltd. strives for the highest levels of quality and accuracy. The information included in this publication is presented for informational purposes only. CVS Controls Ltd. reserves the right to modify or change, and improve design, process, and specifications without written notice. Under no circumstance is the information contained to be interpreted to be a guarantee/warranty with regard to our products or services, applicability or use.

Selection, use and maintenance are the sole responsibility of the end user and purchaser. CVS Controls assumes no liability for the selection use and maintenance of any product.