

Instruction Manual

CVS Type 657 Diaphragm Actuator Sizes 30-70

All CVS Controls equipment, including actuators, are to be installed and maintained in accordance with instructions supplied by CVS Controls. Only qualified personnel may install and service the actuator, and, if necessary, contact a gas service person.

Introduction

The CVS Type 657 Actuator is used for the automatic operation of control valves, and is designed as a direct acting, spring-opposed diaphragm. By varying the pneumatic loading pressure on the actuator diaphragm, the valve plug within the body will open, close or throttle.

When the loading pressure is increased within a direct-acting diaphragm actuator the actuator stem moves downward, compressing the spring. A decrease in pressure will cause actuator stem to move upward with the decompression of the spring (Figure 2).

The valve plug action of the CVS Type 657 Actuator can be set to "push down to close" or "push down to open" and will then either open or close the control valve upon failure of the loading pressure. When the loading pressure fails, the diaphragm of the actuator moves to the extreme upward position and performs the selected action.

Refer to Table 1 for the specifications for various sizes of CVS Type 657 Actuators. All accessories used with the CVS 657 have individual manuals which should be consulted regarding installation, operation and maintenance.



Figure 1: CVS Type 657 Actuator

Installation

The CVS Type 657 Diaphragm Actuator is usually delivered furnished mounted on a CVS Controls valve body. When installing the valve body into the pipeline, consult the instructions for that particular valve body. Should you have any questions during the installation procedure, consult your CVS Controls representative.

The loading pressure is connected to the NPT connection in the top of the diaphragm case (1/4" for sizes 30 through 60, 1/2" size 70). With larger sizes, it may be beneficial to reduce the connection down

Table 1: CVS Type 657 Diaphragm Actuator

Actuator Size	30	34	40	45	46	50	60	70	
Nominal Effective Area (Sq.In.) (Diaphragm)	46	69	69	105	156	105	156	220	
Yoke Boss Size Diameter (In.)	2-1/8	2-1/8	2-13/16	2-13/16	2-13/16	3-9/16	3-9/16	3-9/16	
Valve Body Stem Size (In.)	3/8	3/8	1/2	1/2	1/2	3/4	3/4	3/4	
Maximum Allowable Stem Force (Lbs)	2300	2300	2700	5650	7550	5650	6800	8800	
Maximum Travel (In.)	3/4	1-1/8	1-1/2	2	2	2	2	3	
Maximum Diaphragm Case Pressure (PSI)*	140	75	75	60	50	60	50	65	
Approximate Weight	Kg	16	22	23	37	49	42	53	107
	Lb	36	48	51	82	107	92	116	235

*Maximum allowable diaphragm case pressure may be used only when maximum allowable stem forces are not exceeded.

Installation cont'd

to 1/4". Pipe or tubing may be used, and should be run to the output pressure connection on the automatic controller. Avoid transmission lag in the control signal by keeping the length of pipe or tubing as short as possible. When long distances are involved, install a valve positioner on the actuator. If the valve positioner is provided as part of the original equipment, the loading pressure connection will be made at the CVS Controls manufacturing facility.

If the CVS Type 657 Diaphragm Actuator is shipped alone for field mounting, it should be mounted onto the valve body and secured in place with the yoke locknut. Clamp the actuator stem and valve plug stem together using the stem connector to provide the proper valve travel. Refer to the "Assembly Instructions" section of this manual for complete instructions.

For ease of service, ensure that the control valve is located for easy access and serviceability with room above for accessibility. Ensure that sufficient room is provided below should removal of the actuator and valve plug be necessary.

Operation and Adjustment

Refer to the nameplate on the yoke of the actuator for details on the specific construction and operating range. The requirements of your specific application will dictate the spring and diaphragm used in your CVS Type 657 Actuator. When in service, the actuator will create full travel of the valve plug when diaphragm pressure is applied according to the range indicated on the nameplate. Generally, the diaphragm pressure range is

3 to 15 PSI or 6 to 30 PSI, but other ranges may be used.

Pressure within the valve body creates forces on the valve plug which directly affect the actual operating diaphragm pressure range. When pressure conditions in the valve body are different from those indicated in the factory settings, the valve may not stroke completely over the indicated range. To achieve correct travel for the diaphragm pressure range utilized, a simple spring adjustment is necessary. Note, however, that the actuator spring has a fixed pressure span and that adjustment of the spring compression simply shifts this span up or down to make the travel of the valve correspond with the diaphragm pressure range.

Type 657 Direct Acting Diaphragm Actuator

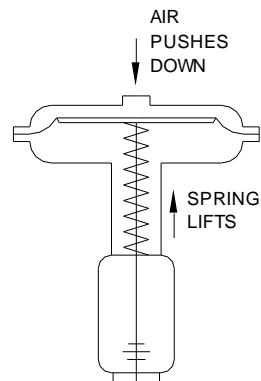

STEM MOVES UPWARD WITH LOSS OF OPERATING MEDIUM

Figure 2: Schematic of CVS Type 657 Actuator

Operation and Adjustment cont'd

The CVS Controls nameplate indicates a “bench set” pressure range in addition to a standard diaphragm pressure range. The “bench set” pressure range indicates the range required to completely stroke the valve with out any pressure in the valve body, for example as if the valve were being tested on the work bench. While In service, however, with the specified pressure drop applied across the valve, it should stroke over the standard diaphragm pressure range as indicated on the nameplate.

Once the control valve has been installed and connected to the controller, it should be tested for correct travel, lack of friction and correct action (air-to-open or air-to-close) to match the controlling instrument. To ensure the most effective operation, the actuator stem and the valve plug stem must move freely when responding to the loading pressure change on the diaphragm.

Disassembly Instructions

Although the following instructions describe how the CVS Type 657 Diaphragm Actuator can be completely disassembled, when inspection or repairs are required, only disassemble those parts required to accomplish the job.

Consult Figure 4, and proceed as follows for disassembly:

1. Bypass the control valve and exhaust any actuator loading pressure to atmospheric. Disconnect the actuator supply line and any leakoff piping.
2. Relieve all pressure from the spring by threading the spring adjuster (key 2) out of the yoke.
3. To remove the valve body from the actuator, separate the stem connector (key 21) and remove the yoke locknut.
4. Loosen the stem locknuts (keys 13 and 14), remove the two cap screws and separate the stem connector.
5. Loosen the diaphragm case cap screws and nuts (keys 19 and 20) and remove the upper diaphragm case.
6. Remove the molded diaphragm (key 6).
7. Extract the diaphragm plate and actuator stem (keys 5 and 3) as an assembly. These parts can be further separated if required.
8. Remove the actuator spring (key 1) and

spring seat (key 4).

9. If necessary, remove the lower half of the diaphragm case (key 8) by loosening the cap screws.
10. Removing the spring adjuster will complete the disassembly.

Assembly Instructions

1. The CVS Type 657 Actuator can be assembled in the reverse order of the disassembly instructions. These additional steps below will assist with proper assembly and continued operation.
2. Apply lubricant to the threads and spring seat bearing surface of the spring adjuster (See location marked “LP” on Figure 4).
3. Ensure that the spring seats and the lower seat align properly and rest against the diaphragm plate.
4. Use a criss-cross pattern to evenly tighten the nuts on the casing bolts.
5. If the stem locknuts were removed during disassembly, install them onto the valve plug stem and place the travel indicator (key 12) with the cupped side downward.
6. Secure the actuator onto the valve body using the yoke locknut.
7. Assemble the stem connection as follows according to the required action:

a. Mounted on Body with “Push Down to Close” Valve Plug

- i. When the body is assembled and the actuator is mounted, ensure the valve plug is in the closed position.
- ii. Once the locknuts are secured onto the stem, set the travel indicator disc onto the locknuts with the cupped portion facing downward.
- iii. Raise the valve plug off of the seat, with the travel specified on the nameplate, or, pressure the actuator until the stem moves down the specified valve travel.
- iv. Install the stem connector by clamping the actuator stem to the valve stem.
- v. Raise the indicator disc to the stem connector, using the locknuts to tighten in position.
- vi. Ensure that the desired total travel is available by cycling the actuator. This will also demonstrate that the valve plug seats properly. If necessary, minor travel adjustments can be made by slightly loosening the stem connector, tightening the locknuts and screwing the stem either into or out of the stem connector using a wrench on the locknuts.

- vii. Once the valve travel has been accomplished, secure the stem connector, lock the travel indicator disc against the connector using the locknuts, and adjust the travel indicator scale (key 16) to show valve plug position.
 - viii. Using a gauge, measure the pressure delivered to the actuator. Make any adjustments on the actuator, or the positioner, to set the starting point of valve travel and ensure full range of travel as desired.
- b. Mounted on Body with “Push Down to Open” Valve Plug**
- i. Attach the locknuts to the stem and set the travel indicator disc into position.
 - ii. Raise the valve plug to the closed position. On larger body sizes, a pry bar may be inserted through the body line flange opening. If the valve is located in a pipeline application, you may remove the bottom flange and raise the valve plug from below.
 - iii. Install the stem connector and ensure that the actuator stem threads are fully engaged.
 - iv. Install the two cap screws in the stem connector to clamp the actuator stem to the valve stem.
 - v. If a pry bar has been used, remove it now. If the bottom flange has been removed, replace it now.
 - vi. Apply loading pressure to the diaphragm case and move the valve plug down off of its seat.
 - vii. Rotate the valve plug stem into the stem connector approximately 1/8". Slightly tighten the stem locknuts to move the travel indicator to the proper position.
 - viii. Check the availability of desired travel by fully cycling the actuator. The valve plug should seat before the upper travel stop. If required, minor adjustments to total travel can be made by slightly loosening the stem connector, tightening the locknuts and screwing the stem either into or out of the stem connector using a wrench on the locknuts.

Note: When making adjustments to the valve stem, do not rotate the valve stem more than the 1/8" that it was screwed into the actuator stem in step "vii". Over rotating the valve stem will prevent the valve from shutting off.

- ix. Proceed with steps "vii" and "viii" as in section "A" above.

Serial Number

Each CVS Type 657 Actuator has a serial number, stamped on the nameplate. When corresponding with your CVS Controls representative, always refer to that serial number when requiring replacement parts or technical information.

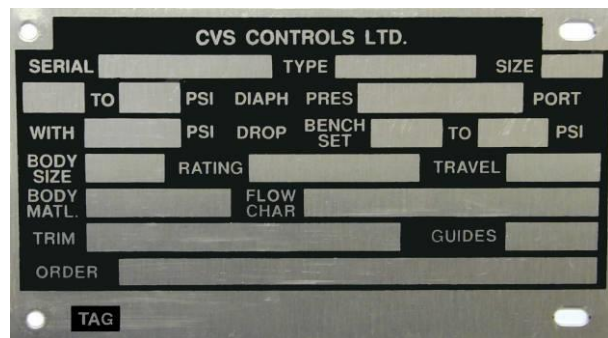

Figure 3: Nameplate on CVS Type 667 Actuator

CVS Type 657 Actuator Parts List

The following parts list includes complete part numbers for components of the CVS Type 657 Actuator that are generally replaceable in the field, and are most commonly used. Key numbers correspond to those in Figure 4. If materials and parts are required, but are not outlined in this literature, consult your CVS Controls representative. Include the serial number of your actuator in all correspondence regarding replacement parts.

CVS Type 657 Actuator

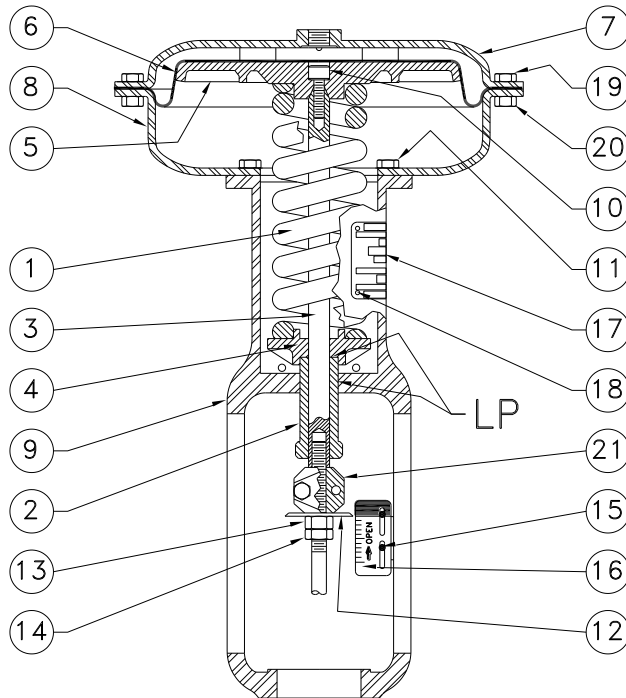

Table 2: Parts Reference

Key	Part Name
1	Actuator Spring
2	Spring Adjuster
3	Actuator Stem
4	Spring Seat
5	Diaphragm Plate
6*	Diaphragm
7	Upper Diaphragm Case
8	Lower Diaphragm Case
9	Yoke
10	Cap Screw
11	Cap Screw
12	Travel Indicator
13	Hex Nut
14	Hex Jam Nut
15	Self-Tapping Screw
16	Travel Indicator Scale
17	Nameplate
18	Drive Screw
19	Cap Screw
20	Hex Nut
21	Stem Connector
22	Twin Speed Nut (not shown)
23	Pipe Bushing (Size 70 only) (not shown)

* Recommended spare part

Figure 4: CVS Type 657 Actuator Assembly Drawing

Table 3: Parts List

Key	Description	Part Number	
1	Actuator Spring	Consult CVS Controls	
2	Spring Adjustor	Size 30	CVS1E792924102
		Sizes 34, 40	CVS1E807324102
		Sizes 45, 46, 50, 60	CVS1E832624102
		Size 70	CVS1N129724102
3	Actuator Stem Steel, CD PL	Size 30	CVS1E792824102
		Size 34	CVS1E872924102
		Size 40	CVS1E807124102
		Sizes 45, 46	CVS1J332924102
		Sizes 50, 60	CVS1E832424102
		Size 70	Up to 2" Travel Over 2" Travel
4	Lower Spring Seat	Size 30, Steel	CVS1U425623122
		Sizes 34,40, Steel	CVS1R179923122
		Sizes 45, 46, 50, 60, Steel	CVS1R180023122
		Size 70, Cast Iron	CVS1N129619052
5	Diaphragm Plate Cast Iron	Size 30	CVS2E880419042
		Sizes 34,40	CVS3E880519042
		Sizes 45, 50	CVS2E831519042
		Sizes 46, 60	CVS2E847519042
		Size 70	CVS2N127019042

CVS Type 657 Actuator

Parts List continued

Key	Description	Part Number		
6	Diaphragm Nitrile	Size 30	CVS2E791902202	
		Sizes 34, 40	CVS2E670002202	
		Sizes 45, 50	CVS2E859502202	
		Sizes 46, 50	CVS2E859702202	
		Size 70	CVS2N126902202	
7	Upper Diaphragm Casing Steel	Size 30	CVS2E791528992	
		Sizes 34, 40	CVS2E806028992	
		Sizes 45, 50	CVS3E830928992	
		Sizes 46, 60	CVS2E847228992	
		Size 70	CVS2N126628992	
8	Lower Diaphragm Casing Steel	Size 30	CVS2E792225062	
		Sizes 34, 40	CVS2E806325062	
		Sizes 45, 50	CVS3E831625062	
		Sizes 46, 60	CVS2E847425062	
		Size 70	CVS2N127125062	
9	Yoke Cast Iron	Size 30	CVS3E792619042	
		Size 34	CVS2E869619042	
		Size 40	CVS3E807019042	
		Sizes 45, 46	CVS2E903719042	
		Sizes 50, 60	CVS3E832319042	
		Size 70	CVS3N127319042	
10	Cap Screw Steel, CD PL	Size 30	CVS1E798032982	
		Sizes 34, 40	CVS1E760432992	
		Sizes 45, 46, 50, 60, 70	CVS1E775432982	
11	Cap Screw	Push Down to Close Valve	Size 30 (6 req'd)	CVS1D529824052
			Sizes 34, 40 (6 req'd)	CVS1A368424052
			Sizes 45, 46, 50, 60 (8 req'd)	CVS1A368424052
			Size 70	CVS1N129328992
		Push Down to Open Valve	Size 30 (3 req'd)	CVS1D368424052
			Sizes 34, 40 (3 req'd)	CVS1A368424052
			Sizes 45, 46, 50, 70 (4 req'd)	CVS1A368424052
			Size 70 (9 req'd)	CVS1N129328992
12	Travel Indicator, SST	Sizes 30, 34	CVS1E793138992	
		Sizes 40, 45, 46	CVS1E807238992	
		Sizes 50, 60, 70	CVS1B832838992	
13	Hex Nut, SST	Sizes 30, 34 (2 req'd)	CVS1P131224142	
		Size 40, 46	CVS1A413224122	
		Sizes 50, 60, 70	CVS1A375424122	
14	Hex Jam Nut, SST	Size 40	CVS1A353724122	
		Sizes 45, 46 (2 req'd)	CVS1A353724122	
		Sizes 50, 60, 70	CVS1A351124122	
15	Self-tapping Screw, SST	Sizes 30, 34, 45, 46 (2 req'd)	CVS11793238992	
		Sizes 50, 60, 70 (2 req'd)	CVS1E831338992	
16	Travel Indicator Scale, SST	See following Table 4		
17	Nameplate, SST	CVS12B6508X0A2		
18	Drive Screw, SST (4 req'd)	CVS1A368228982		
19	Cap Screw, Standard 3/8" Bolt	Size 30, 34, 40, 45, 50, 60	1" bolt	
		Size 70	1-1/4" bolt	
20	Hex Nut, Standard 3/8" Nut	1" Nut		
21	Stem Connector, STL	Sizes 30, 34	CVS1E7977000A2	
		Size 40	CVS1F659225142	
		Sizes 45, 46	CVS1J3330000A2	
		Sizes 50, 60	CVS1E8337000A2	
		Size 70	CVS1H8655000A2	
22	Twin Speed Nut, SST	Sizes 30, 34	CVS1E793938992	
		Sizes 40, 45, 46	CVS1E808438992	
		Sizes 50, 60, 70	CVS1E833538992	
23	Pipe Bushing, Steel, PL	Size 70	CVS1C379026232	

Table 4: Travel Indicator Scale

Actuator Size	Part Numbers				
	3/4" Travel	1-1/8" Travel	1-1/2" Travel	2" Travel	3" Travel
30, 34	CVS1E793638992				
40, 45, 46	CVS1E808138992	CVS1E808228992	CVS1E808338992	CVS1R444538982	
50, 60	CVS1E833138992	CVS1E833128992	CVS1E833338992	CVS1E833428992	
70	CVS1E833138992	CVS1E833238992	CVS1E833338992	CVS1E833438992	1N129838992

Table 5: Thrust Capabilities by Input Signal Range

Travel	Actuator Size	Pressure Range to Actuator Diaphragm	Thrust Capabilities
		Bar	N
19	30	0.2-1	2250
		0.4-2	3890
	34	0.2-1	3380
		0.4-2	5830
29	40	0.2-1	3380
		0.4-2	5530
	45	0.2-1	4670
		0.4-2	8410
	46	0.2-1	6940
		0.4-2	13,190
38	50	0.2-1	5140
		0.4-2	8410
	60	0.2-1	6940
		0.4-2	13,190
51	70	0.2-1	7930
		0.4-2	18,590
Inch		Psig	Lb
3/4	30	3-15	506
		6-30	874
	34	3-15	759
		6-30	1311
1-1/8	40	3-15	759
		6-30	1242
	45	3-15	1050
		6-30	1890
	46	3-15	1560
		6-30	2964
1-1/2	50	3-15	1155
		6-30	1890
	60	3-15	1560
		6-30	2964
2	70	3-15	1760
		6-30	4180