

ULTRA-WIDE PPW Variable Range Proportioners

Features

- UL Listed/FM Approved with CHEMGUARD C3B 3% AFFF and CHEMGUARD C334-LV 3x3 AR-AFFF concentrates
- 6 in. and 8 in. models with various flow ranges as low as 51 gpm and as high as 4,875 gpm (193 Lpm to 18,450 Lpm)
- Compact, corrosion-resistant design
- Maintenance-free construction
- Mounts between the same nominal size flanges without a spool piece for water inlet and foam solution outlet
- Ease of recharge and post-fire cleanup
- 2 in. raised face 150 lb ANSI flange foam inlet for all models

Application

CHEMGUARD ULTRA-WIDE PPW variable range proportioners are part of an in-line balanced proportioning system using an atmospheric foam concentrate tank connected to a positive displacement foam concentrate pump. The proportioner design provides accurate flow control of a foam liquid concentrate stream over a wide range of flow rates and pressures. CHEMGUARD C3B 3% AFFF and CHEMGUARD C334-LV 3x3 AR-AFFF concentrates are the only concentrates approved for use with the proportioners.

Common applications include:

- Flammable liquid storage where protection requires multiple devices with a wide range of flow rates, such as tank farm protection systems per NFPA 11 using foam chambers, or other means of foam delivery where varied flow rates are encountered in addition to low flow requirements for a supplementary foam handline(s).
- Closed head foam-water sprinkler systems for warehouse storage, chemical processing, loading racks, and any location where flammable liquids are used, stored, processed, or transported.

Note: The converted values in this document are provided for dimensional reference only and do not reflect an actual measurement.

CHEMGUARD, ULTRA-WIDE, and the product names listed in this material are marks and/or registered marks. Unauthorized use is strictly prohibited.



009100

Description

CHEMGUARD ULTRA-WIDE PPW variable range proportioning systems function by maintaining equal pressures in the foam concentrate and water inlets to the proportioner. This balancing ability and a variable orifice allows the proportioner to be used over a wider range of flows and pressures than standard balanced pressure pump proportioners. The system will also respond quickly and accurately to changes in the water inlet pressures and flow rates.

The system utilizes a positive displacement foam pump to pressurize foam concentrate within the supply manifold. A pressure control valve, located in the return line to the foam concentrate storage tank, is set to maintain a regulated pressure in the supply manifold at a minimum of 15 psi to 30 psi (1 bar to 2 bar) higher than the maximum pressure in the water supply line. Foam concentrate, not required by the proportioner, returns to the atmospheric storage tank through the pressure control valve.

The balancing valve in the proportioner senses the foam concentrate pressure and automatically adjusts to balance it with water pressure. As foam concentrate enters the proportioner, a variable orifice regulates the flow of pressurized foam concentrate entering the water stream.

The units are available in two standard sizes, 6 in. and 8 in., with flow rates from 51 gpm to 4,875 gpm (193 Lpm to 18,450 Lpm) (see System Information Table). Each unit consists of a foam proportioner, pressure balancing valve, and pressure sensing tubing.

The proportioner construction includes a bronze body, stainless steel deflector, stainless steel spring, stainless steel foam metering cone and orifice, and a bronze balancing valve with stainless steel fasteners.

The proportioner is installed between either 6 in. or 8 in. pipe flanges (flat or raised face) corresponding with the proportioner size. To assist with proper installation, the body is marked with arrows to indicate direction of flow for water and foam concentrate. A minimum of 5 nominal diameters of straight pipe is required in the water line upstream of the proportioner, and a minimum 2.5 nominal diameters of straight pipe downstream of the proportioner.

Description (Continued)

SYSTEM INFORMATION TABLE

Model	ULTRA-WIDE PPW-6	ULTRA-WIDE PPW-6	ULTRA-WIDE PPW-8	ULTRA-WIDE PPW-8
Agent	CHEMGUARD C334-LV 3x3 AR-AFFF	CHEMGUARD C3B 3% AFFF	CHEMGUARD C334-LV 3x3 AR-AFFF	CHEMGUARD C3B 3% AFFF
Size	6 in.	6 in.	8 in.	8 in.
UL Listed				
Flow	gpm 51 to 3,015	55 to 3,009	62 to 4,968	56 to 4,630
Range	(Lpm) (193 to 11,413)	(208 to 11,390)	(235 to 18,806)	(212 to 7,530)
FM Approved				
Flow	gpm 55 to 3,230	56 to 3,023	N/A	N/A
Range	(Lpm) (208 to 12,227)	(193 to 11,413)		
Maximum				
Working	psi 250	250	250	250
Pressure	(bar) (17.2)	(17.2)	(17.2)	(17.2)

Approvals

CHEMGUARD PPW-6 variable range proportioners are UL Listed and FM Approved with both the CHEMGUARD C3B 3% AFFF and CHEMGUARD C334-LV 3x3 AR-AFFF foam concentrates. The CHEMGUARD PPW-8 variable range proportioners are UL Listed with these two foam concentrates.

Note: ULTRA-WIDE PPW-6 proportioners are only FM Approved when used in conjunction with the specific foam concentrates and equipment shown in the Approval Guide (www.ApprovalGuide.com).

Specifications

The CHEMGUARD ULTRA-WIDE PPW variable range proportioner assembly shall have all necessary components factory assembled and tested including: foam proportioner, pressure balancing valve, and pressure sensing copper tubing.

Materials of construction shall be a bronze body, stainless steel deflector, stainless steel spring, stainless steel foam metering cone and orifice, and a bronze balancing valve with stainless steel fasteners. Interconnecting foam concentrate piping shall be of bronze construction.

The body shall be clearly marked with foam concentrate and water supply flow direction arrows. The nameplate shall identify the type and percent of foam concentrate that may be proportioned.

Balancing shall be accomplished through the use of a diaphragm type pressure balancing valve that automatically adjusts the foam concentrate pressure according to the water pressure.

The foam concentrate inlet shall be a 2 in. 150 lb raised face ANSI flange. The water supply inlet/outlet wafer shall fit between either flat face or raised face pipe flanges matching the proportioner nominal diameter.

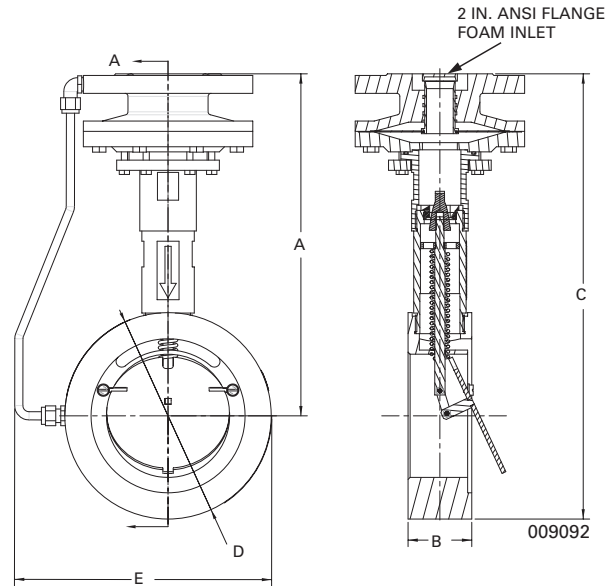

Dimensions

Model: Size:	PPW-6 6 in.		PPW-8 8 in.	
	in.	(mm)	in.	(mm)
Dimension				
A	13.13	(333)	15.47	(393)
B	2.44	(62)	3.25	(83)
C	17.13	(435)	20.87	(530)
D	7.91	(201)	10.63	(270)
E	10.83	(275)	13.59	(345)
* Minimum Upstream pipe length	30.00	(762)	40.00	(102)
** Minimum Downstream pipe length	15.00	(381)	20.00	(508)

* See Note 5 on next page

**See Note 6 on next page

Ordering Information

Part No.	Description	Approximate Shipping Weight		Approvals
		lb	(kg)	
702003	ULTRA-WIDE PPW-6, 6 in. proportioner for CHEMGUARD C3B 3% AFFF	50	(23)	UL Listed, FM Approved
702004	ULTRA-WIDE PPW-6, 6 in. proportioner for CHEMGUARD C334-LV 3x3 AR-AFFF	50	(23)	UL Listed, FM Approved
702005	ULTRA-WIDE PPW-8, 8 in. proportioner for CHEMGUARD C3B 3% AFFF	90	(41)	UL Listed
702006	ULTRA-WIDE PPW-8, 8 in. proportioner for CHEMGUARD C334-LV 3x3 AR-AFFF	90	(41)	UL Listed

Typical CHEMGUARD ULTRA-WIDE PPW Variable Range Proportioning System

Notes:

1. In stationary installations utilizing AR-AFFF foam concentrates approximately 1/4 in. (7 mm) of mineral oil should be applied to the surface of the foam concentrate to minimize the effects of evaporation. Mineral oil should never be applied to other types of foam concentrates or to tanks on mobile or vibration-prone equipment.
2. Foam system may be wet pipe, dry pipe, pre-action, deluge, or manual type. See product installation sheet for requirements if proportioner will be installed in normally dry piping.
3. Arrows indicate direction of flow.
4. The hydraulic concentrate valve may be eliminated only on manual systems where the operator will manually open the concentrate valve.
5. Straight pipe length minimum is 5 times proportioner diameter.
6. Straight pipe length minimum is 2.5 times proportioner diameter.

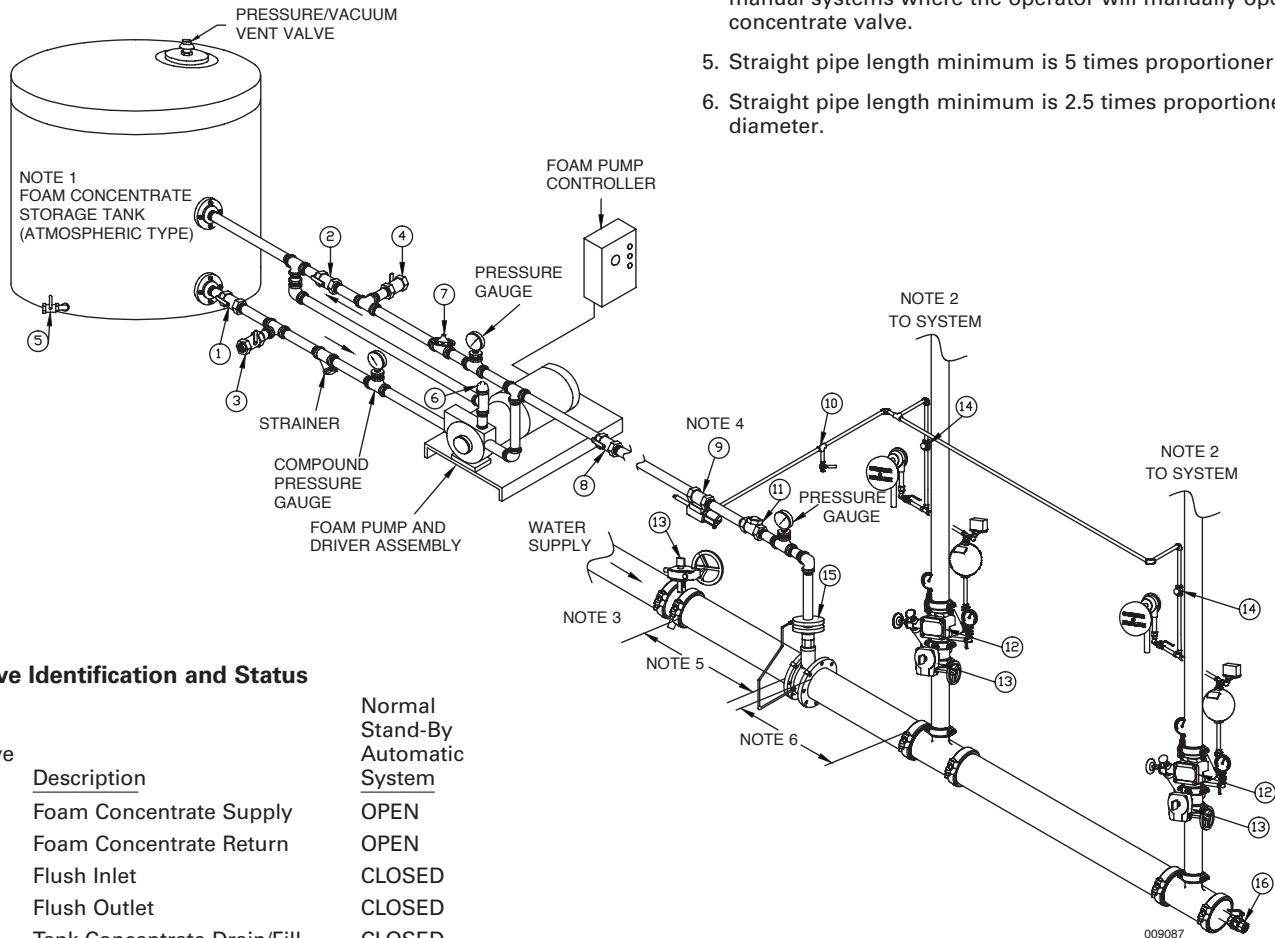

Valve Identification and Status

Valve No.	Description	Normal Stand-By Automatic System
1	Foam Concentrate Supply	OPEN
2	Foam Concentrate Return	OPEN
3	Flush Inlet	CLOSED
4	Flush Outlet	CLOSED
5	Tank Concentrate Drain/Fill	CLOSED
6	Pressure Relief	---
7	Pressure Sustaining (Control)	---
8	Concentrate Supply	OPEN
9	Hydraulic Concentrate	CLOSED
10	Drain Valve or Drain Plug	CLOSED
11	Swing Check	---
12	Sprinkler Valve Deluge (TYP)	CLOSED
13	Butterfly / OS&Y	OPEN
14	Check Valve	---
15	ULTRA-WIDE PPW Proportioner	---
16	Drain or Test Connection	CLOSED

Friction Loss Curve (Through Proportioner)

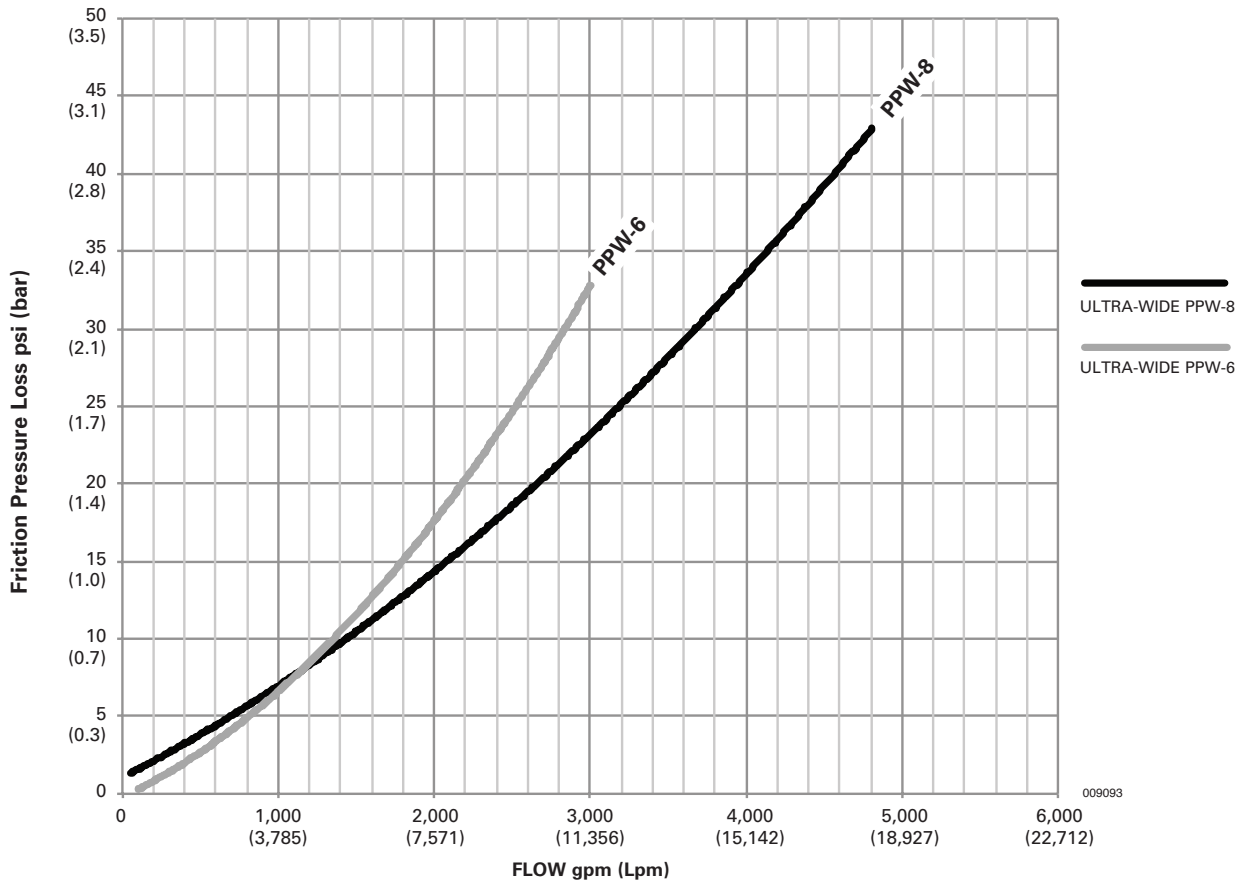

Minimum Inlet Pressure Versus Water Flow

