

Flanged Proportioners (3, 4, 6, and 8 in.)

Application

CHEMGUARD proportioners are specifically designed to accurately proportion and control the mixing of pressurized CHEMGUARD foam concentrates into a water stream with minimum pressure loss. CHEMGUARD proportioners are UL Listed and FM Approved with various CHEMGUARD foam concentrates and they are used in conjunction with bladder tanks. Typical applications include flammable liquid storage tanks, loading racks, aircraft hangars, heliports, and anywhere flammable liquids are used, stored, processed, or transported.

Description

Each CHEMGUARD proportioner consists of a body, inlet nozzle, and metering orifice, all of which are corrosion-resistant brass.

The proportioner body is designed with flat-faced flanges to match ANSI 150 lb flanges of the same nominal size. Clearly marked on the proportioner body is the flow direction arrow, as well as the type and percentage of the designated concentrate.

The inlet nozzle is secured by a stainless steel retaining ring that is internally concealed to prevent removal after installation.

The metering orifice is sized according to the type and percentage of concentrate used and is also secured with a stainless steel retaining ring.

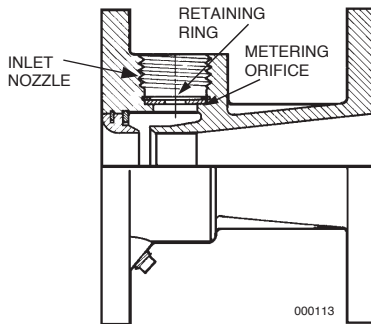

Specifications

The proportioner body and inlet nozzle shall be of low zinc (less than 15%) brass. The nozzle and foam orifice retaining rings shall be of stainless steel.

The proportioner body shall be designed to connect to ANSI 150 lb flat-faced flanges; removal shall be possible without disassembly of additional pipe sections. The two proportioner flange mating faces shall be machined with 64 grooves per inch (25 mm) to capture and seal against the flange gaskets.

The body shall be clearly marked with a flow direction arrow, and the type and percent of foam concentrate that it was designed to proportion.

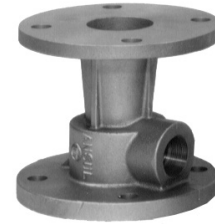

001152

The convergent inlet nozzle shall have a rounded inlet and a smooth machined finish to ensure minimum stream constriction and maximum velocity. It shall be retained by an internally concealed retaining ring that prevents removal after installation.

The foam concentrate metering orifice shall be machined to the proper diameter for the agent. It shall rest on a machined surface to prevent leakage and shall be secured by a removable stainless steel retaining ring.

Ordering Information

Concentrate Used	Proportioner Part No.			
	3 in.	4 in.	6 in.	8 in.
1% AFFF (C1B)	702200*	702209*	702218*	702227*
3% AFFF (C3B)	702201**	702210**	702219**	702228**
3% AFFF (C306-MS)	702240*	702241*	702242*	702243*
3% AFFF (Low Temperature)	702202	702211	702220	702229
3% AR-AFFF (C334-LV)	702792**	702793**	702794**	702795**
3% AR-AFFF (C364)	702203*	702212*	702221*	702230*
6% AFFF	702204*	702213*	702222*	702231*
6% AR-AFFF (C364)	702205*	702214*	702223*	702232*
3% Fluoroprotein Foam	702206	702215	702224	702233
2% High-Expansion C2	702207*	702216*	702225*	702234
Shipping Weight	22 lb (54 kg)	50 lb (10 kg)	75 lb (23 kg)	120 lb (34 kg)

* UL Listed with Bladder Tanks

** UL Listed and FM Approved with Bladder Tanks.

Proportioners are only FM Approved when used in conjunction with the specific foam concentrates and equipment shown in the Approval Guide (www.approvalguide.com).

Proportioner Dimension Table

Proportioner Size	A in. (mm)	B in. (mm)	C in.	D in. (mm)	E in. (mm)	F in. (mm)
3 in.	7.5 (191)	6.50 (165)	1 1/4 NPT	2.66 (68)	15 (381)	1.75 (443)
4 in.	9.0 (229)	10.00 (254)	1 1/2 NPT	4.00 (102)	20 (508)	3.00 (762)
6 in.	11.0 (279)	12.75 (324)	2 NPT	4.63 (118)	30 (762)	3.06 (777)
8 in.	13.5 (343)	13.50 (343)	2 1/2 NPT	6.38 (162)	40 (1016)	3.50 (889)

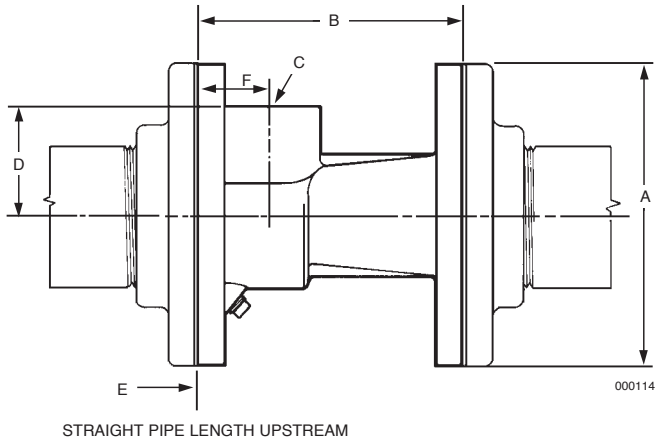

Note: The converted values in this document are provided for dimensional reference only and do not reflect an actual measurement.

CHEMGUARD and the product names listed in this material are marks and/or registered marks. Unauthorized use is strictly prohibited.

Nominal Flow Ranges

The following table lists the nominal flow range for each proportioner size. For flow ranges using specific concentrates, consult Tyco Fire Protection Products Technical Services.

Proportioner Size	Nominal Flow Range gpm	(Lpm)
3 in.	70 – 800	(265 – 3028)
4 in.	200 – 1600	(757 – 6057)
6 in.	300 – 3400	(1136 – 12870)
8 in.	500 – 5500	(1892 – 20819)

Note: Refer to UL Online Certification Directory or FM Approval Guide for concentrate-specific flow ranges.

Minimum Inlet Pressure Versus Water Flow

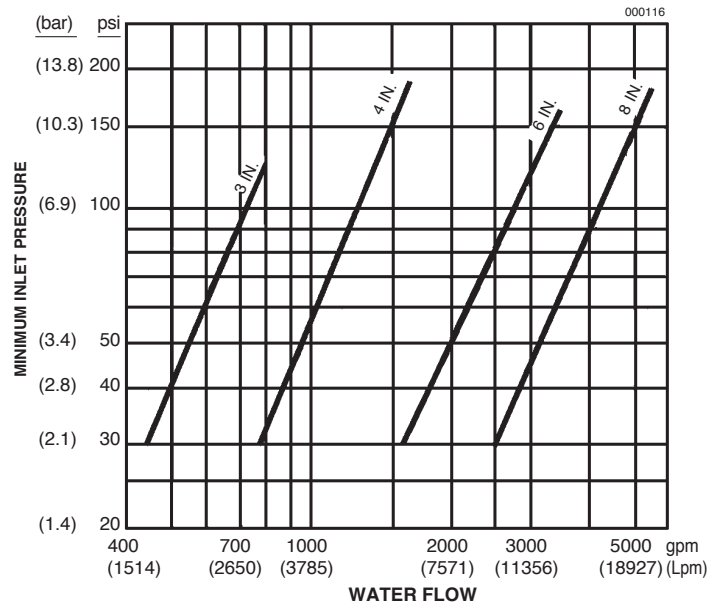

Friction Loss Curves

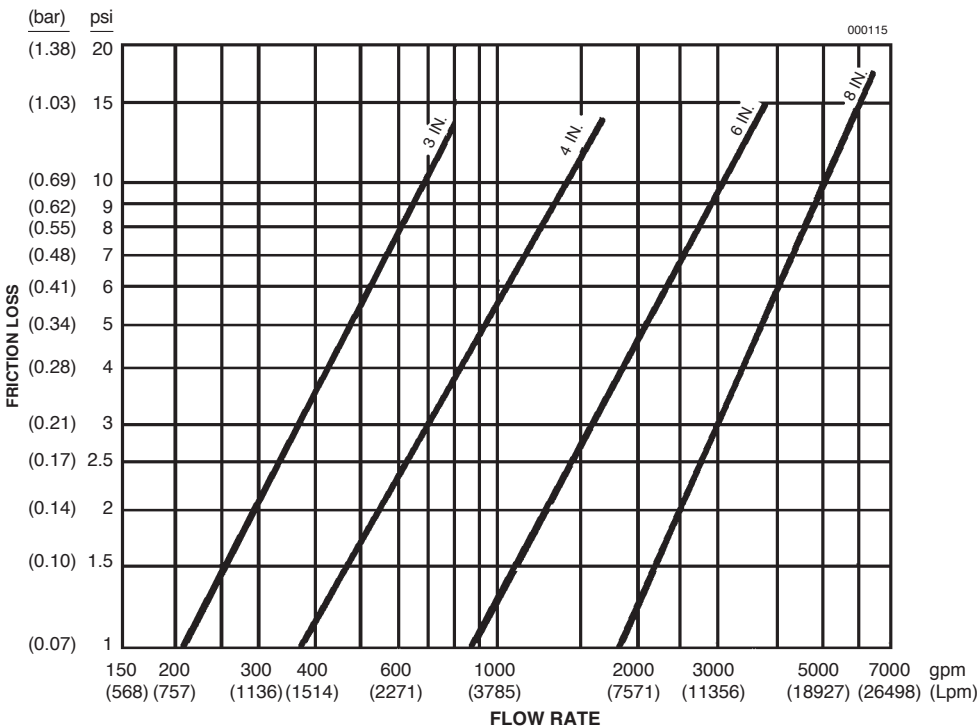

Note: Consult Technical Services to determine proportioner size and maximum pipe run between foam tank and proportioner when using AR-AFFF Concentrate.