

In-Line Balanced Pressure Proportioners Models CIBP, CIBP-M

Features

- Six standard sizes to handle a wide range of flows with minimal friction loss
- Spool valve design ensures accurate pressure regulation and rapid response to changes in flow demand
- Brass foam concentrate piping with stainless steel trim accessories standard for use in marine applications and other corrosive environments
- Compatible with all CHEMGUARD foam concentrates
- Choice of unpainted brass or standard red paint finish

Application

CHEMGUARD In-Line Balanced Pressure Proportioners are used with an atmospheric foam concentrate tank and a positive displacement foam concentrate pump. In-line balanced pressure proportioners are designed to accurately control the flow of a foam liquid concentrate into a water stream over a wide range of flow rates and pressures. Advantages of the in-line balanced pressure proportioner include the following:

- Multiple proportioning devices can be used with a single pressurized foam concentrate supply.
- Foam concentrate can be proportioned near the discharge devices while the foam concentrate storage tank and pump are placed in a remote location.
- Water supply pressure can vary at proportioners under simultaneous operation without affecting foam solution concentration.
- Various sizes of in-line balanced pressure proportioners can be combined in a single system to best suit the flow requirements of each hazard area.

Description

The in-line balanced pressure proportioning system functions by maintaining an equal pressure in the foam concentrate and water inlets to the proportioner. This balancing ability allows the proportioner to be used over a wide range of flows and pressures. The system will also respond quickly and accurately to changes in the water inlet pressures and flow rates.

The system utilizes a positive displacement foam pump to pressurize foam concentrate within the supply manifold. A pressure control valve, located in the return line that leads to the foam concentrate storage tank, is set to maintain a regulated pressure in the supply manifold that is higher than the pressure in the water supply line. The foam concentrate that is not required by the proportioner is returned to the atmospheric storage tank through the pressure control valve. The spool valve senses the foam concentrate pressure and automatically adjusts to balance it with the water pressure.

A duplex pressure gauge provides a reading of the foam concentrate and water pressures.



009829

The foam concentrate then enters the proportioner, where a built-in orifice regulates the flow of pressurized foam concentrate entering the water stream.

The units are available in six standard sizes to supply proportioners ranging from 2 in. to 8 in. with flow rates from 30 gpm to 5,500 gpm (114 Lpm to 20,820 Lpm) as listed under the System Information Table. Each unit consists of a foam proportioner, pressure balancing spool valve, duplex gauge, various control valves, drain valves, check valves, interconnecting brass pipe and fittings, stainless steel braid flexible pressure sensing hoses, and valve identification nameplates. The CIBP-M models are also provided with a manual foam balancing valve. The in-line balanced pressure proportioner is factory pressure tested after being assembled.

Approvals

The CHEMGUARD CIBP in-line proportioner is UL Listed with various CHEMGUARD foam concentrates. For specific concentrates and corresponding flow ranges, consult Tyco Fire Protection Products Technical Services.

Specifications

The in-line balanced pressure proportioner assembly shall contain all necessary components including: foam proportioner, pressure balancing spool valve, duplex gauge, control valves, drain valves, check valves, interconnecting brass pipe, and valve identification nameplates.

Balancing shall be accomplished through the use of a spool-type pressure balancing valve. This valve shall sense foam concentrate and water inlet pressures at the outer ends of a dumbbell-shaped piston, and shall react to pressure changes by covering or uncovering the foam supply port to the proportioner. The balancing valve shall be low zinc (less than 15%) brass construction with a bronze piston and Buna-N rubber O-rings and seals. The in-line balanced pressure proportioner shall be completely pressure tested by the manufacturer.

Interconnecting foam concentrate piping shall be of brass construction. Pressure sensing hoses shall be TEFLON¹ material with a stainless braid cover and permanently attached brass couplings. Valve nameplates shall be provided, and shall specify valve function and normal operating position. The "foam concentrate" ball valve shall have a ring pin and chain for securing the ball valve in the operating position.

System Information Table

The following table lists the nominal flow range for each proportioner size. For flow ranges using specific concentrates, consult Tyco Fire Protection Products Technical Services.

Proportioner Size	Model CIBP-2/CIBP-2M	Model CIBP-2 1/2/CIBP-2 1/2M	Model CIBP-3/CIBP-3M	Model CIBP-4/CIBP-4M	Model CIBP-6/CIBP-6M	Model CIBP-8/CIBP-8M
Nominal Flow Range gpm	30-300	35-400	70-800	200-1600	300-3400	500-5500
Nominal Flow Range (Lpm)	(114-1136)	(132-1514)	(265-3028)	(757-6057)	(1136-12870)	(1892-20819)

In-line balanced pressure proportioner systems will proportion slightly higher concentrations at the low end of the nominal flow range.

Note: Listed Nominal Flow Ranges do not apply for Alcohol Resistant Concentrate.

In-Line Balanced Pressure Proportioners (Models CIBP-2 to CIBP-8)

	Model CIBP-2		Model CIBP-2 1/2		Model CIBP-3		Model CIBP-4		Model CIBP-6		Model CIBP-8	
	in.	(mm)	in.	(mm)	in.	(mm)	in.	(mm)	in.	(mm)	in.	(mm)
Dimension A	-		-		17	(430)	18 1/2	(470)	18 1/4	(460)	22 1/2	(570)
Dimension B	16	(410)	16	(410)	-		-		-		-	
Dimension C	16 3/4	(430)	16 3/4	(430)	16 3/4	(430)	16 3/4	(430)	16 3/4	(430)	20	(510)
Dimension D	9	(230)	9	(230)	9 3/4	(250)	10 1/2	(270)	12	(310)	14	(360)
Dimension E	1 3/4	(45)	1 3/4	(45)	1 3/4	(45)	1 3/4	(45)	1 3/4	(45)	2 3/16	(55)
Dimension F	1 NPT		1 NPT		1 NPT		1 1/2 NPT		1 1/2 NPT		2 NPT	
Dimension G	2 NPT		2 1/2 NPT		3*		4*		6*		8*	

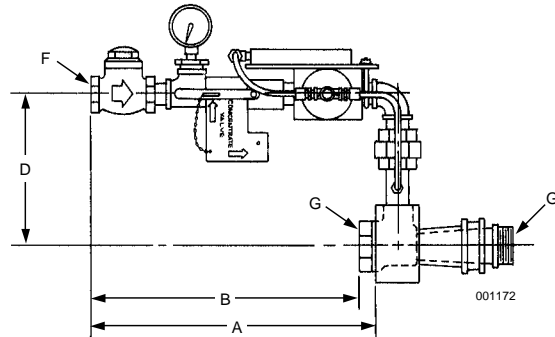
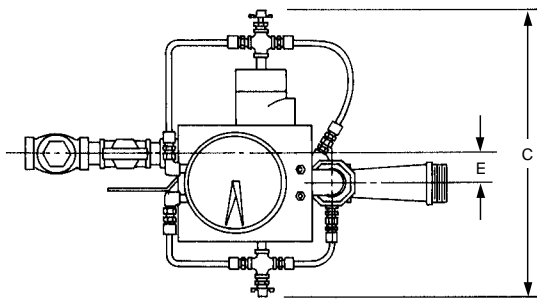

In-Line Balanced Pressure Proportioners With Manual Foam Balancing Valve (Models CIBP-2M To CIBP-8M)

	Model CIBP-2M		Model CIBP-2 1/2M		Model CIBP-3M		Model CIBP-4M		Model CIBP-6M		Model CIBP-8M	
	in.	(mm)	in.	(mm)	in.	(mm)	in.	(mm)	in.	(mm)	in.	(mm)
Dimension A	-		-		25 1/2	(650)	28 1/2	(720)	28	(710)	32 3/8	(820)
Dimension B	24 1/2	(620)	24 1/2	(620)	-		-		-		-	
Dimension C	16 3/4	(430)	16 3/4	(430)	16 3/4	(430)	16 3/4	(430)	16 3/4	(430)	20	(510)
Dimension D	15 5/8	(400)	15 5/8	(400)	16 3/8	(420)	18	(460)	19 1/2	(500)	22 1/2	(570)
Dimension E	9	(230)	9	(230)	9 3/4	(250)	10 1/2	(270)	12	(310)	14	(360)
Dimension F	1 3/4	(45)	1 3/4	(45)	1 3/4	(45)	1 3/4	(45)	1 3/4	(45)	2 3/16	(55)
Dimension G	1 NPT		1 NPT		1 NPT		1 1/2 NPT		1 1/2 NPT		2 NPT	
Dimension H	2 NPT		2 1/2 NPT		3*		4*		6*		8*	

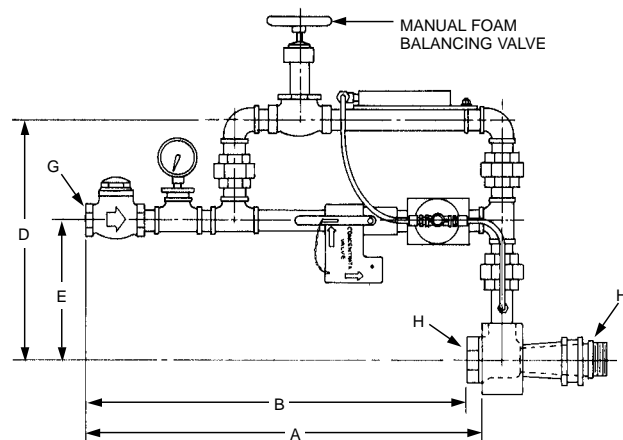
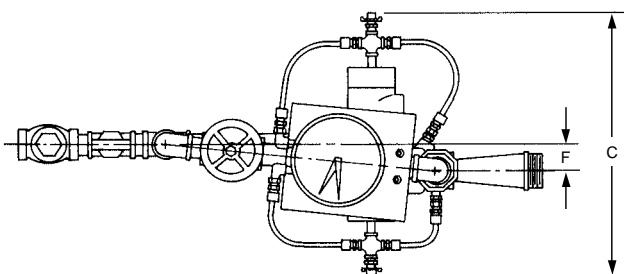

*Between flange proportioner is standard. Upon request, proportioners can also be supplied in flanged style.

Note: In-line balanced pressure proportioners require a minimum of 5 pipe diameters of straight, unobstructed water inlet supply pipe.

001173

Ordering Information

Part No.	Part No. Standard	Description	Approximate Shipping Weight	
Unpainted	Red Paint		lb	(kg)
702500	702506	Model CIBP-2 In-line Proportioner Assembly	45	(20.4)
702501	702507	Model CIBP-2 1/2 In-line Proportioner Assembly	45	(20.4)
702502	702508	Model CIBP-3 In-line Proportioner Assembly	50	(22.7)
702503	702509	Model CIBP-4 In-line Proportioner Assembly	65	(29.5)
702504	702510	Model CIBP-6 In-line Proportioner Assembly	80	(36.3)
702505	702511	Model CIBP-8 In-line Proportioner Assembly	135	(61.2)
702512	702518	Model CIBP-2M In-line Proportioner Assembly	60	(27.2)
702513	702519	Model CIBP-2 1/2M In-line Proportioner Assembly	60	(27.2)
702514	702520	Model CIBP-3M In-line Proportioner Assembly	65	(29.5)
702515	702521	Model CIBP-4M In-line Proportioner Assembly	90	(40.8)
702516	702522	Model CIBP-6M In-line Proportioner Assembly	105	(47.6)
702517	702523	Model CIBP-8M In-line Proportioner Assembly	170	(77.1)

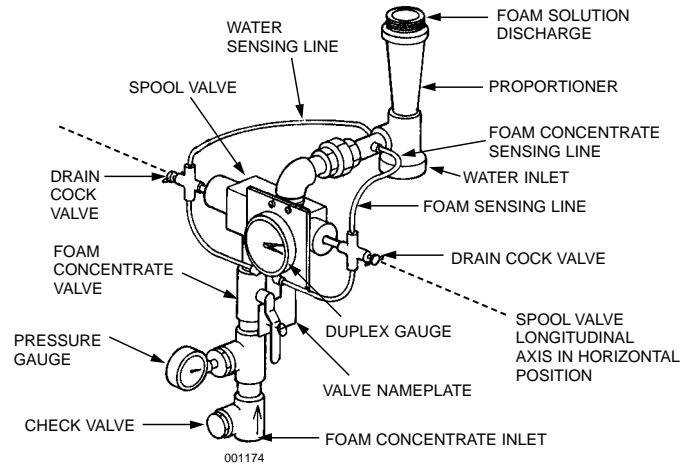

Note: Spool valve must be installed with the longitudinal axis in the horizontal (level) position.

Safety Data Sheet (SDS) available at www.chemguard.com

Note: The converted metric values in this document are provided for dimensional reference only and do not reflect an actual measurement.

¹TEFLON is a trademark of its respective owner.

CHEMGUARD and the product names listed in this material are marks and/or registered marks. Unauthorized use is strictly prohibited.

Typical In-Line Balanced Pressure Proportioning System

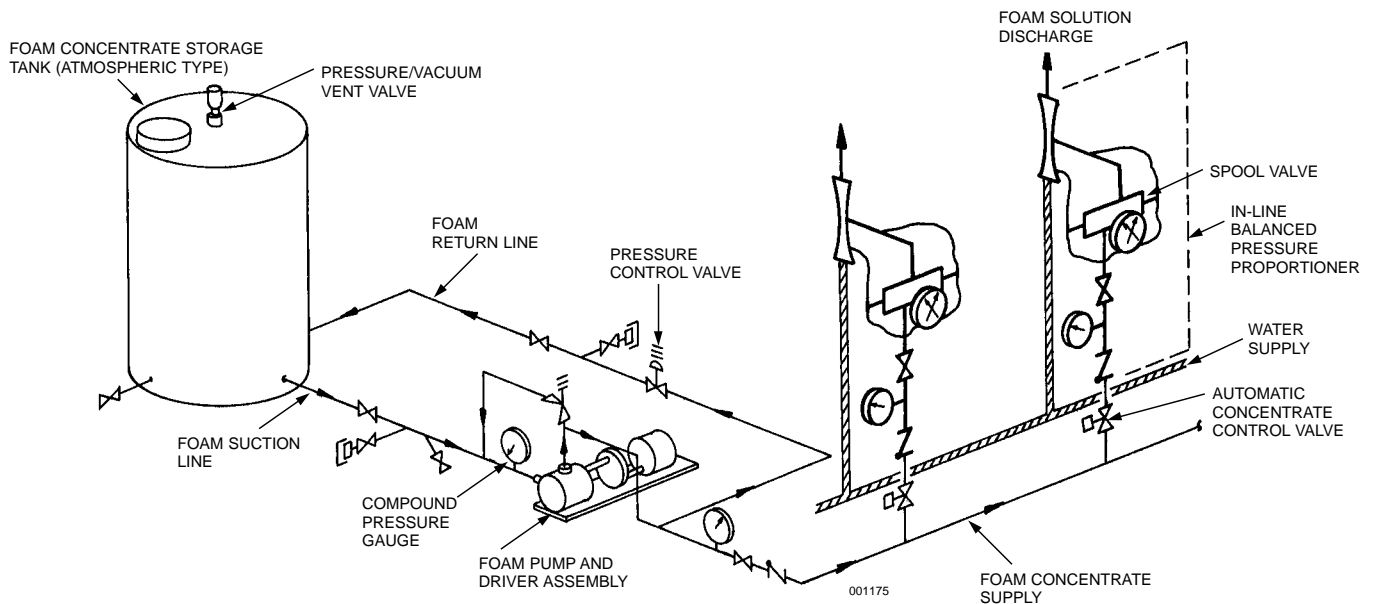

NOTE: Flush connections are only required with protein based foam concentrates.

LEGEND:

	SHUT-OFF VALVE		PRESSURE GAUGE		PROPORTIONER		SPOOL VALVE
	CHECK VALVE		DUPLEX PRESSURE GAUGE		FLUSH CONNECTION		DIRECTION OF FLOW
	PRESSURE RELIEF VALVE		COMPOUND PRESSURE GAUGE		STRAINER		

