

## Hydraulic Concentrate Control and Accessory Valves

### Applications

The hydraulic concentrate control valve is designed for use in either a CHEMGUARD bladder tank system or an In-Line Balanced Pressure (ILBP) proportioning system. The valve is used to automatically open the line supplying concentrate to the foam proportioner. FM Approved versions are available and include a factory-installed supervision module for monitoring valve position. The supervision module is also available as a retrofit kit to add supervisory capability to CHEMGUARD Hydraulic Concentrate Control Valves in existing installations. The valve actuator operates by the pressure of the inlet water supply and requires no electrical power. If electrical actuation is preferred, solenoid valves in 24 VDC and 120 VAC versions are available for installation in the water inlet piping.

### Description

Standard valve sizes are available from 1 in. to 2 1/2 in. to match the concentrate inlet thread size on the full range of CHEMGUARD proportioners and In-line Balanced Pressure Proportioner assemblies. Each hydraulic concentrate control valve assembly consists of a factory assembled and tested ball valve, hydraulic actuator, and mounting kit attaching the actuator to the ball valve. The actuator has a position indicator and manual override capability. The internal components of the actuator are designed to be compatible for use with pressurized water which is used as the means of actuation. The actuator is a double-acting type: the pressurized water supplied to the actuator can be used to either close or open the valve. However, for foam concentrate lines, the valve is normally closed and is hydraulically opened for system use. Care should be taken to ensure that the proper pressure sensing port is utilized on the actuator to drive the valve to the desired position (closed or open).

The hydraulic concentrate control valve can be used in conjunction with any type of closed-head sprinkler system (wet pipe, dry pipe, and pre-action). It can also be used in open-type deluge systems. To pressurize the valve, the water line is commonly run from the alarm trim of the sprinkler valve (see "Typical Piping Arrangement"). The pressure sensing line to the actuator should be a minimum of 1/4 in. pipe or alternate 3/8 in. tubing (the actual connection to the actuator is 1/8 in. NPT). The actuators are sized to operate with a minimum pressure of 30 psi (2.1 bar). Technical Services should be consulted for applications where the water pressure potentially could be lower. The maximum recommended water pressure to the actuator is 160 psi (11 bar). For higher pressures, a 1/4 in. FM Approved WATTS<sup>1</sup> Pressure Reducing Valve (Part No. 415020) should be installed in the line to the actuator.



WATTS PRESSURE REDUCING VALVE  
006741



HYDRAULIC CONCENTRATE CONTROL VALVE  
009862

### Specifications

The hydraulic concentrate control valve consists of items that have been factory assembled and tested, including:

- A threaded bronze body ball valve, with mounting pad, designed for a minimum 400 psi (27.6 bar) WOG. This valve is fitted with a stainless steel ball, a stem, and a packing nut. The valve seats are made of glass reinforced TEFLON<sup>1</sup> material.
- The hydraulic actuator is approved by the manufacturer for the use of water as the operating medium and is designed with a minimum operating pressure of 30 psi (2.1 bar) and a maximum operating pressure of 160 psi (11 bar).
- FM Approved versions include a factory-installed supervision module for monitoring valve position.
- The actuator is equipped with a position indicator and can be manually overridden if necessary. No manual operating handle is included to minimize the potential for tampering or fouling in adjacent piping.
- A mounting kit for securely attaching the hydraulic actuator to the ball valve.

Refer to the following chart to determine the size of the hydraulic control valve when the size of the proportioner has been determined.

### Valve Size Required

Proportioner Size	Bladder Tank System	Pump System (In-Line Balance Pressure)
2 in.	1 in.	1 in.
2 1/2 in.	1 in.	1 in.
3 in.	1 1/4 in.	1 in.
4 in.	1 1/2 in.	1 1/2 in.
6 in.	2 in.	1 1/2 in.
8 in.	2 1/2 in.	2 in.

## Ball Valves and Swing Check Valves

CHEMGUARD ball valves and swing check valves are available for use with most bladder tank foam systems. All valves are of bronze construction and have NPT connections. The water inlet and concentrate isolation ball valves feature nameplates with their respective name, ring pin, and tamper seal for visually monitoring that the position of the valves are correct.



**APOLLO<sup>1</sup> WATER INLET BALL VALVE**  
006739



**APOLLO CONCENTRATE ISOLATION BALL VALVE**  
006738



**SWING CHECK VALVE**  
006742

## Typical Piping Arrangement

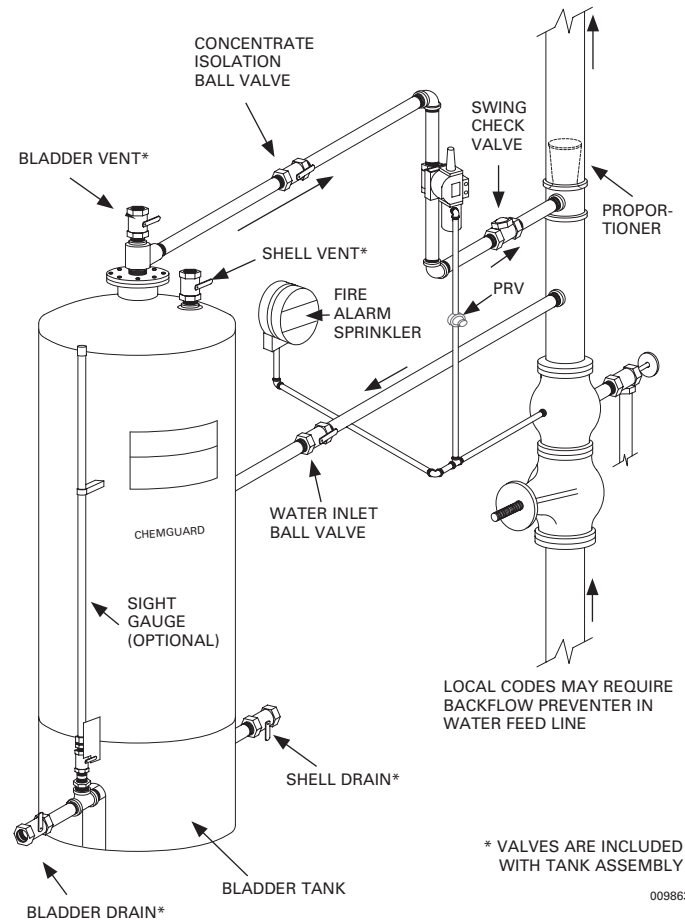

009863

## Typical In-line Balanced Pressure Proportioning System

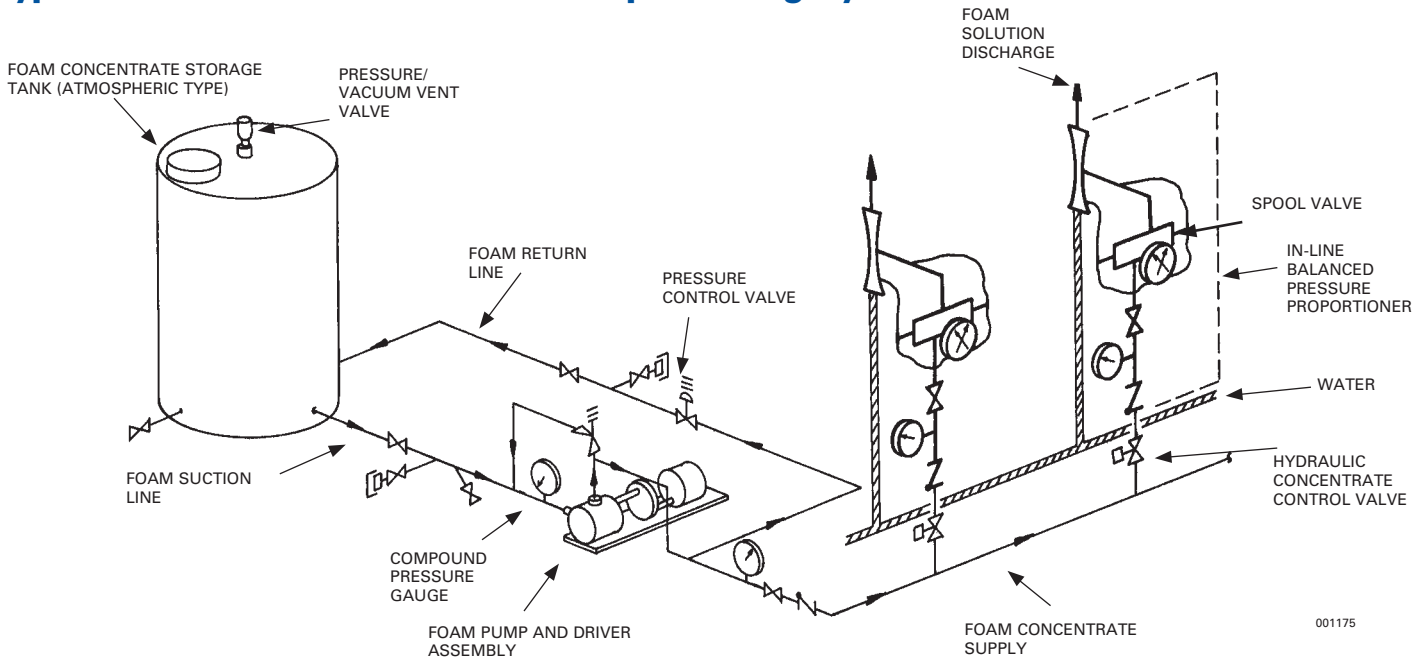

001175

## Ordering Information

Unless stated otherwise, all valve bodies are bronze construction with female NPT connections.

Part No.	Description	Valve Length**		Approximate Shipping Weight		Approvals^
		in.	(mm)	lb.	(kg)	
68787	Water Inlet Ball Valve/Nameplate, 1 in.	3.50	(90)	1	(0.5)	
68822	Water Inlet Ball Valve/Nameplate, 1 1/4 in.	4.00	(100)	1	(0.5)	
68788	Water Inlet Ball Valve/Nameplate, 1 1/2 in.	4.50	(110)	1	(0.5)	
68789	Water Inlet Ball Valve/Nameplate, 2 in.	4.75	(120)	2	(1.0)	
74202	Water Inlet Ball Valve/Nameplate, 2 1/2 in.	6.50	(170)	2	(1.0)	
404669	Water Inlet Ball Valve/Nameplate, 3 in.	6.75	(170)	2	(1.0)	
74188	Concentrate Isolation Ball Valve/Nameplate, 1 in.	3.50	(90)	1	(0.5)	
74192	Concentrate Isolation Ball Valve/Nameplate, 1 1/4 in.	4.00	(100)	1	(0.5)	
74196	Concentrate Isolation Ball Valve/Nameplate, 1 1/2 in.	4.50	(110)	1	(0.5)	
74200	Concentrate Isolation Ball Valve/Nameplate, 2 in.	4.75	(120)	2	(1.0)	
74203	Concentrate Isolation Ball Valve/Nameplate, 2 1/2 in.	6.50	(170)	2	(1.0)	
404670	Concentrate Isolation Ball Valve/Nameplate, 3 in.	6.75	(170)	2	(1.0)	
403155	Swing Check Valve, 1 in.	3.25	(80)	2	(1.0)	
403780	Swing Check Valve, 1 1/4 in.	4.00	(100)	2	(1.0)	
403781	Swing Check Valve, 1 1/2 in.	4.50	(110)	2	(1.0)	
403782	Swing Check Valve, 2 in.	5.25	(130)	3	(1.4)	
403080	Swing Check Valve, 2 1/2 in.	6.25	(160)	3	(1.4)	
65987	Hydraulic Concentrate Control Valve, 1 in.	3.25	(80)	10	(4.5)	
65988	Hydraulic Concentrate Control Valve, 1 1/4 in.	3.75	(90)	15	(6.8)	
403490	Hydraulic Concentrate Control Valve, 1 1/2 in.	4.25	(100)	20	(9.0)	
403491	Hydraulic Concentrate Control Valve, 2 in.	4.75	(120)	20	(9.0)	
403827	Hydraulic Concentrate Control Valve, 2 1/2 in.	6.50	(170)	30	(13.6)	
443678	Hydraulic Concentrate Control Valve, 1 in., Supervised	3.25	(80)	15	(6.8)	FM Approved
443679	Hydraulic Concentrate Control Valve, 1 1/4 in., Supervised	3.75	(90)	20	(9.0)	FM Approved
443680	Hydraulic Concentrate Control Valve, 1 1/2 in., Supervised	4.25	(100)	25	(11.3)	FM Approved
443681	Hydraulic Concentrate Control Valve, 2 in., Supervised	4.75	(120)	25	(11.3)	FM Approved
443682	Hydraulic Concentrate Control Valve, 2 1/2 in., Supervised	6.50	(170)	35	(15.9)	FM Approved
415020	Pressure Reducing Valve (Brass), 1/4 in.	1.50	(40)	2	(1.0)	FM Approved
443686	Supervision Retrofit Kit (1 in. Valves)	NA	NA	5	(2.3)	
445499	Supervision Retrofit Kit (1 1/4, 1 1/2, 2, 2 1/2 in. Valves)	NA	NA	5	(2.3)	
445494	24 VDC Solenoid Kit	1.69	(40)	2	(0.9)	
445495	120 VAC Solenoid Kit	1.69	(40)	2	(0.9)	

### Stainless Steel Valves

431763	Hydraulic Concentrate Control Valve, Flanged, Stainless Steel, 1 in.*	5.00	(130)	14	(6.6)	
431764	Hydraulic Concentrate Control Valve, Flanged, Stainless Steel, 1 1/2 in.*	6.50	(170)	26	(12.0)	
431765	Hydraulic Concentrate Control Valve, Flanged, Stainless Steel, 2 in.*	7.00	(180)	37	(16.8)	

## Ordering Information (Continued)

Part No.	Description	Valve Length**		Approximate Shipping Weight		Approvals^
		in.	(mm)	lb.	(kg)	
443683	Hydraulic Concentrate Control Valve, Flanged, Stainless Steel, 1 in., Supervised	5.00	(130)	19	(8.6)	FM Approved
443684	Hydraulic Concentrate Control Valve, Flanged, Stainless Steel, 1 1/2 in., Supervised	6.50	(170)	31	(14.1)	FM Approved
443685	Hydraulic Concentrate Control Valve, Flanged, Stainless Steel, 2 in., Supervised	7.00	(180)	42	(19.0)	FM Approved
431766	Ball Valve, Flanged, Stainless Steel, 1 in.	5.00	(130)	8	(3.6)	
431767	Ball Valve, Flanged, Stainless Steel, 1 1/2 in.	6.50	(170)	14	(6.4)	
431768	Ball Valve, Flanged, Stainless Steel, 2 in.	7.00	(180)	21	(9.5)	
470757	Ball Valve, Flanged, Stainless Steel, 2 1/2 in.	7.50	(190)	34	(15.5)	
431769	Swing Check Valve, Flanged, Stainless Steel, 1 in.	5.00	(130)	8	(3.6)	
431770	Swing Check Valve, Flanged, Stainless Steel, 1 1/2 in.	6.50	(170)	15	(6.8)	
431771	Swing Check Valve, Flanged, Stainless Steel, 2 in.	8.00	(203)	24	(10.9)	
470946	Swing Check Valve, Flanged, Stainless Steel, 2 1/2 in.	8.50	(216)	46	(21.6)	

\* Contact Johnson Controls Technical Services for details.

\*\*Nominal length dimension is from thread outlet. Dimensions are approximate and subject to change without notice.

^ Components are only FM Approved when used in conjunction with specific foam concentrates and/or equipment shown in the Approval Guide ([www.ApprovalGuide.com](http://www.ApprovalGuide.com)).

**Note:** The converted values in this document are provided for dimensional reference only and do not reflect an actual measurement.

<sup>1</sup>TEFLON, APOLLO, and WATTS are trademarks of their respective owners.

CHEMGUARD and the product names listed in this material are marks and/or registered marks. Unauthorized use is strictly prohibited.