

**FIXED GAS
DETECTION
SYSTEM**



Fixed Gas Detection System BDS-2000

B-I BDS-2000 model is designed to provide a solution for all your safety monitoring and marine application requirements. The BDS-2000 detects flammable gases, oxygen and most of toxic gases.

The BDS-2000 can be accessed and customized for various applications such as offshore plants, public buildings, car parks, boiler rooms, petrochemical plants, semiconductor plants, and etc.

The BDS-2000 control panel monitors sequentially each identified zone on 40 digits LCD and one control panel of BDS-2000 is capable of analyzing 64 detectors. The device adopted RS485 communication system to save the installation cost. All information data including audible & visual alarms easily can be transmitted through personal computer from local control room to main central headquarters.

The BDS-2000 Fixed Gas Detection System can be also interfaced to BDS-4000 Fire & Gas Detection System.

The free arrangement of each different kind of gas detector up to 64 detectors is one of the most important features and the unlimited quantities of detectors can be achieved by adding of our small control panels.

The control panel can be used for Fire Detection System and the unlimited quantities of conventional Smoke/Heat Detectors can be connected to the control panel.

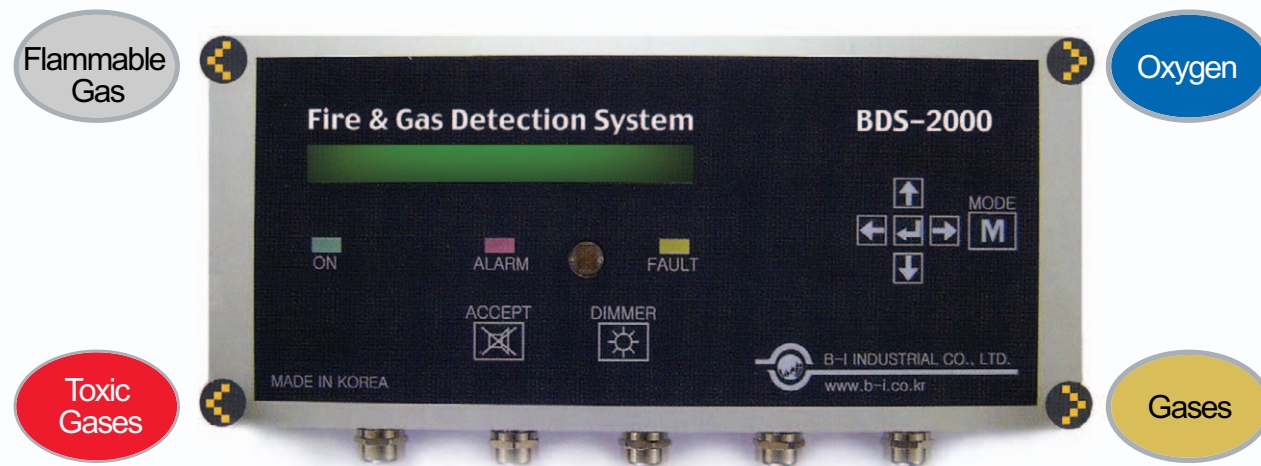

Features

- Integrated Fire & Gas Detection System
- Able to measure Smoke, Heat, Flame, and various Gases by Detection Head Type at one time
- Sequential Display on LCD for each zone
- Optional DC24 Volt Emergency Battery Back Up System
- User Friendly Repeater Panel
- Data Interface between VDR and Navigation Equipments
- Various Applications to meet any industries and space
- Simple & Easy Operation (in Normal Condition)
- Real-time Monitoring System

Intrinsically Safe Gas & Smoke Monitoring System

The BDS-2000 Gas & Fire Detection System is a real time monitoring system to analyze Flammable Gases, Toxic gases and Smoke in hazardous area.

The system is a intrinsically safe of smoke detection system(Ex ia IIC T4) and internal pressure explosion proof type(Ex id IIC T4) of gas detection system able to be installed in hazardous area, pump room, cargo hold, air conditioning system in accommodation area and etc.

The BDS-2000 system can be accessed and customized for various applications such as offshore projects, gas plants, petrochemical plants, car parks in commercial building and subway train station.

The system adopted RS485 serial communications system with RS232 system. Various external devices with much more control panels and repeater panels easily can be connected to Interface Unit.

Applications

- Void Space Gas Detection
- Accommodation Air Conditioning Inlet Gas Detection
- Pump Room Gas Detection
- Container Cargo Hold Monitoring System

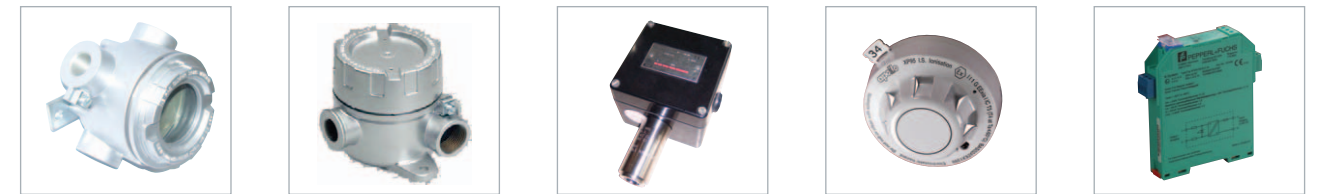

Fixed Gas Detection System Configuration(BDS-2000)

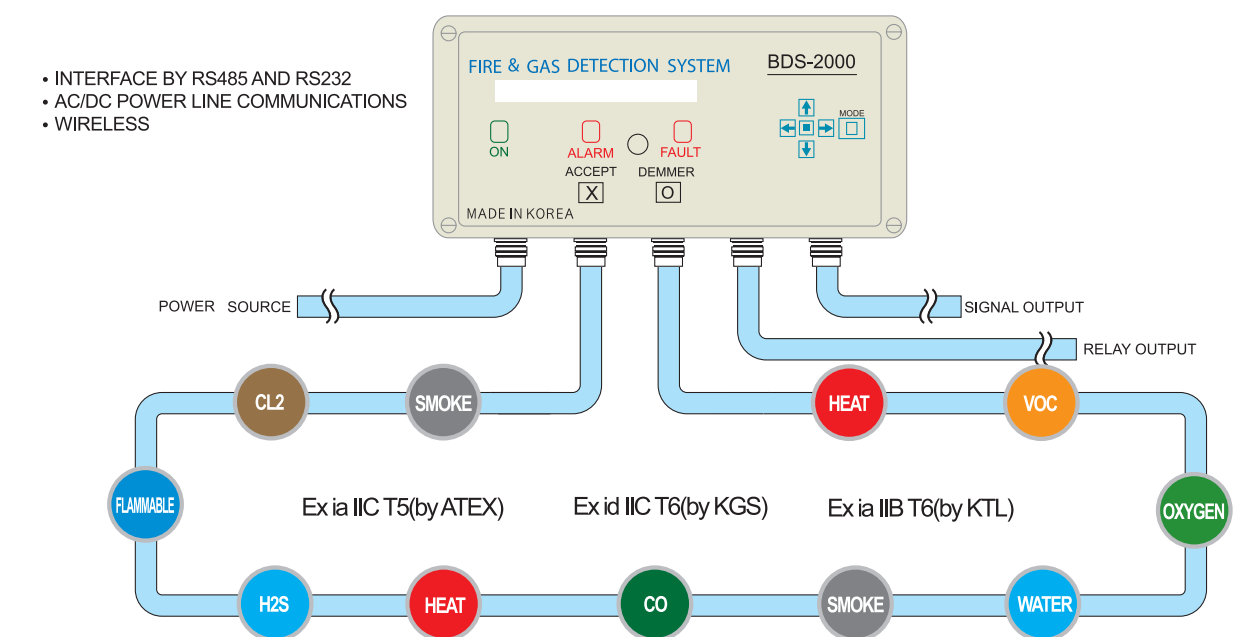

FIXED GAS
DETECTION
SYSTEM



Gas Sampling System for Ballast Tanks & Void Spaces

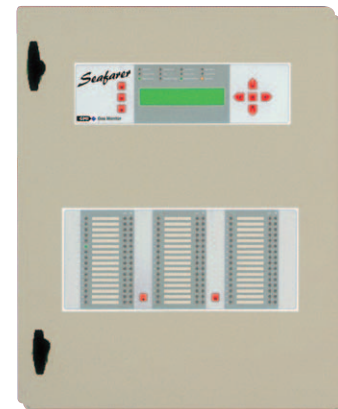

Seafarer Sequential Gas Sampling System

Designed to monitor gas levels in marine applications from a number of sample points, targeted where the positioning of conventional gas sensors may not be practical. This may be due to equipment security, cable routing, access for detector head installation/ maintenance or harsh environments.

Measurements

- Combustible Gas : LEL; % Vol.
- Toxic Gas : PPM; % Vol.
- Oxygen : % Vol.
- Refrigerant : ppm

Features

- 1-48 Sample points
- Full indication of all operations
- Line blockage and pump fail monitoring
- Selectable sample line sequence
- High integrity, comprehensive self check fault monitoring
- Centralised one man calibration offers minimum running costs
- Display of each sample line location
- Option as follows - Split system operation ; Remote repeater panel ;
Line blockage, Blow back ; LED : text indicator panel ; Hazardous area
operation ; Autoflood cut off ; Enclosure internal gas monitoring with automatic system shutdown
- Monitor up to 4 gas types
- 4 Line alpha / numeric display
- Variable sample time for optimum cycle time
- No sample line purge delay
- Easily installed and maintained
- Event logging / Modbus / RS232 / RS485

OPERATION : Gas samples are sequentially extracted for a timed period by a central control unit via fixed sample lines. A high rate sample is taken by the main pump during which a reduced rate sample is passed across the sensor device. The central unit provides gas level readouts with two alarm trip points per line, providing a range of signal outputs for annunciator and control functions.

Certificate



Fixed Gas Detection System BDS-2000

