



Ultra Low Flow AQUAMIST Type ULF AM33 Horizontal Sidewall Nozzles Automatic (Closed)

General Description

TYCO Ultra Low Flow AQUAMIST Type ULF AM33 Horizontal Sidewall Nozzles are closed (automatic) nozzles intended for use with engineered, water mist systems. They are low-pressure nozzles that utilize a single fluid jet impinging on a diffuser to produce a spray having a range of water droplet sizes suitable for the control of Class A fires.

It is recommended that the end-user be consulted with respect to the suitability of the materials of construction for any given corrosive environment. The effects of ambient temperature, concentration of chemicals, and gas/chemical velocity should be considered, at a minimum, along with the corrosive nature to which the nozzles may be exposed.

NOTICE

The AQUAMIST Type ULF AM33 Nozzles described herein must be installed and maintained in compliance with this document and with the applicable standards of the CEA 4001 "Sprinkler Systems Planning and Installation", or EN12845 "Automatic Sprinkler Systems - Design, Installation and Maintenance", in addition to the standards of any authorities having jurisdiction. Failure to do so may impair the performance of these devices.

IMPORTANT

Refer to Technical Data Sheet TFP2300 for warnings pertaining to regulatory and health information.

Always refer to Technical Data Sheet TFP700 for the "INSTALLER WARNING" that provides cautions with respect to handling and installation of sprinkler systems and components. Improper handling and installation can permanently damage a sprinkler system or its components and cause the sprinkler to fail to operate in a fire situation or cause it to operate prematurely.

The design of individual water mist systems can vary considerably, depending on the characteristics and nature of the hazard and the basic purpose of the water mist system. Because of these variations, the design of water mist systems for fire protection must only be performed by experienced designers who thoroughly understand the limitations as well as capabilities of such systems.

The owner is responsible for maintaining their fire protection system and devices in proper operating condition. Contact the installing contractor or product manufacturer with any questions.

Approvals

TYCO Ultra Low Flow AQUAMIST Type ULF AM33 Horizontal Sidewall Nozzles are intended to be used as part of an engineered, wet-pipe water mist system. Testing was performed in accordance with the accommodations portion of VdS test protocol "Protection of Office Spaces and Accommodation Areas with Water Mist Sidewall Sprinklers", dated April, 2016.

Technical Data

Discharge Coefficient

$K=30,85 \text{ LPM}/\text{bar}^{1/2}$ ($K=2.14 \text{ GPM}/\text{psi}^{1/2}$)

Thread Connection

1/2 in. NPT

Response Time Index (RTI)

Quick Response

Finish

Natural Brass
Pure White
Signal White
Chrome Plated

Temperature Ratings

57 °C (135 °F)

Physical Characteristics

Frame Brass
Strainer Copper
Orifice Insert Bronze
Button Bronze
Sealing Assembly .. Beryllium Nickel w/TEFLON
Ejection Spring Stainless Steel
Bulb Glass
Diffuser Stainless Steel

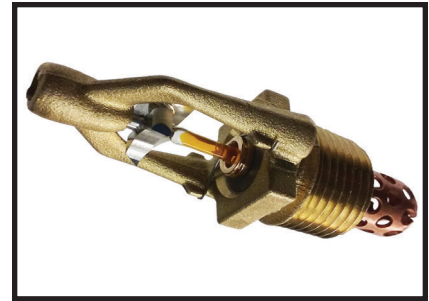

The smallest waterway (orifice) diameter of the Orifice Insert is nominally 7,54 mm (0.297 in.). The diameter of the Inlet Strainer perforations is nominally 3,2 mm (0.125 in.).

Design Criteria

Obtain guidance for the design of a water mist system that utilizes the TYCO Ultra Low Flow AQUAMIST Type ULF AM33 Horizontal Sidewall Nozzles from the Technical Services department.

Installation

TYCO Ultra Low Flow AQUAMIST Type ULF AM33 Horizontal Sidewall Nozzles must be installed in accordance with this section.

Do not install any bulb type nozzle if the bulb is cracked or there is a loss of liquid from the bulb. With the nozzle held horizontally, a small air bubble should be present. The diameter of the air bubble is approximately 1,6 mm (1/16 in.) for the 57°C (135°F) temperature rating.

A leak-tight 1/2 in. NPT nozzle joint should be obtained by applying a minimum-to-maximum torque of 9,5 to 19,0 N·m (7 to 14 ft·lb). Higher levels of torque can distort the nozzle inlet and cause leakage or impairment of the nozzle.

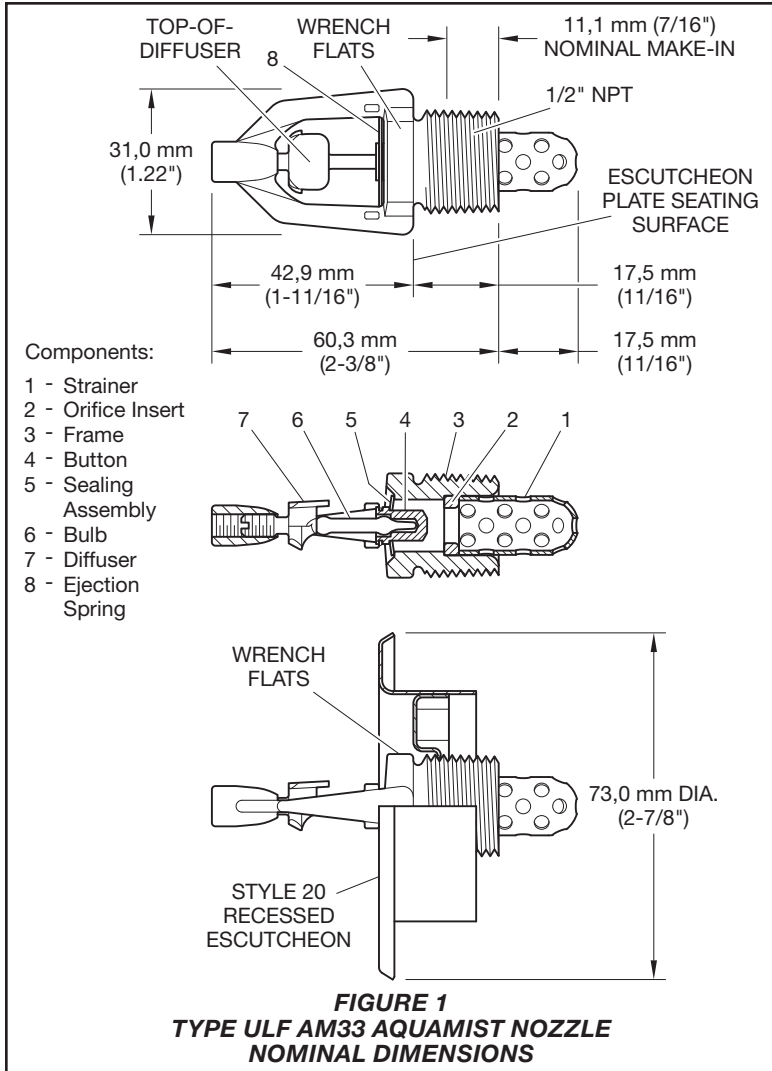

Type ULF AM33

The AQUAMIST Type ULF AM33 Nozzles must be installed in accordance with the following instructions.

Step 1. Install the Type ULF AM33 Nozzles in the horizontal position as shown in Figure 1.

Step 2. With pipe thread sealant applied to the pipe threads, hand-tighten the nozzle into the nozzle fitting.

Step 3. Tighten the nozzle into the nozzle fitting using only the W-Type 6 Wrench. Refer to Figure 3 for more information. With reference to Figure 1, apply the W-Type 6 Wrench to the wrench flats. Align the hood of the diffuser so it is parallel to the ceiling.

Step 4. After installation is complete, remove the bulb protector from the nozzle.

Type ULF AM33 Recessed

The Type ULF AM33 AQUAMIST Recessed Nozzles must be installed in accordance with the following instructions.

Step A. Install the Recessed Type ULF AM33 in the horizontal position as shown in Figure 2.

Step B. After installing the Style 20 Mounting Plate, as applicable, over the nozzle threads and with pipe-thread sealant applied to the pipe threads, hand-tighten the nozzle into the nozzle fitting.

Step C. Tighten the nozzle into the nozzle fitting using only the W-Type 7 Recessed Sprinkler Wrench. Refer to Figure 4 for more information. With reference to Figure 1, apply the W-Type 7 Recessed Sprinkler Wrench to the nozzle wrench flats.

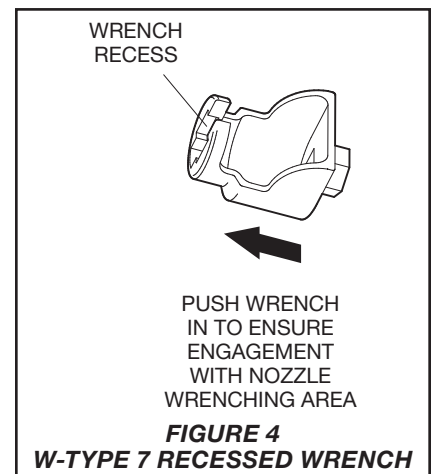
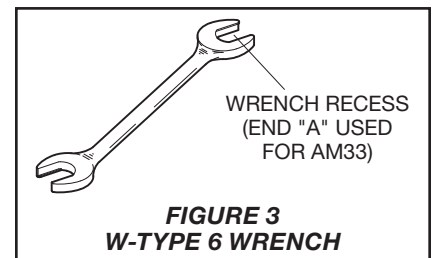
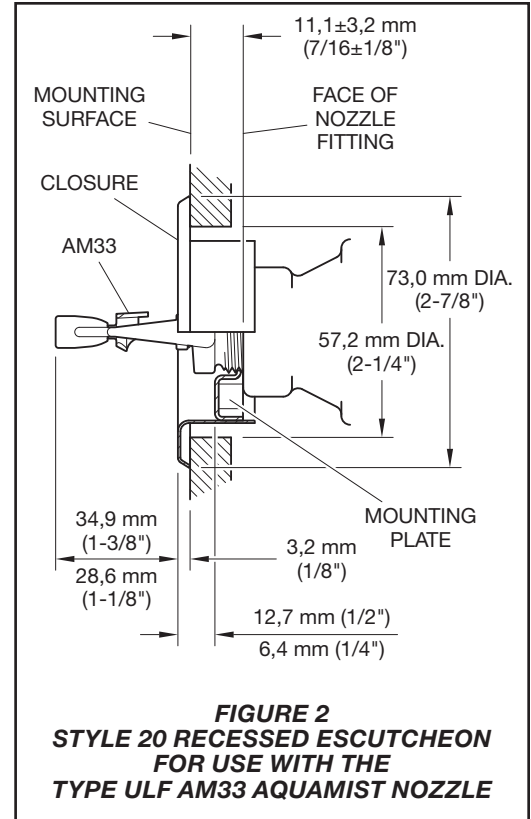

Step D. After the wall has been installed or the finish coat has been applied, slide on the Style 20 Closure over the Type ULF AM33 Nozzle and push the Closure over the Mounting Plate until its flange comes in contact with the wall.

Step E. After installation is complete, remove bulb protector from nozzle.

Note: *Absence of a Style 20 Recessed Escutcheon, which is used to cover a clearance hole, can delay the time to nozzle operation in a fire situation.*

Care and Maintenance

The TYCO Ultra Low Flow AQUAMIST Type ULF AM33 Horizontal Sidewall Nozzles must be maintained and serviced in accordance with this section.

Before closing a fire protection system main control valve for maintenance work on the fire protection system that it controls, obtain permission to shut down the affected fire protection system from the proper authorities and notify all personnel who may be affected by this action.

Nozzles which are found to be leaking or exhibiting visible signs of corrosion must be replaced.

Automatic nozzles must never be painted, plated, coated, or otherwise altered after leaving the factory. Modified nozzles must be replaced. Nozzles that have been exposed to corrosive products of combustion, but have not operated, should be replaced if they cannot be completely cleaned by wiping the nozzle with a cloth or by brushing it with a soft bristle brush.

Care must be exercised to avoid damage to the nozzles before, during, and after installation. Nozzles damaged by dropping, striking, wrench twist/slippage, or the like, must be replaced. Also, replace any nozzle that has a cracked bulb or that has lost liquid from its bulb. Refer to the Installation section for more information.

Frequent visual inspections are recommended to be initially performed for nozzles installed in potentially corrosive atmospheres to verify the integrity of the materials of construction and finish as they may be affected by the corrosive conditions present for a given installation. Thereafter, annual inspections per applicable standards are required, in addition to inspections required by the authority having jurisdiction.

The owner is responsible for the inspection, testing, and maintenance of their fire protection system and devices in compliance with this document, as well as with the applicable standards of any other authorities having jurisdiction. Contact the installing contractor or product manufacturer with any questions.

Water mist systems should be inspected, tested, and maintained by a qualified Inspection Service in accordance with local requirements and/or national codes.

Limited Warranty

For warranty terms and conditions.

Ordering Procedure

Contact your local distributor for availability. When placing an order, indicate the full product name and part number (P/N).

Type ULF AM33 AQUAMIST Nozzles
Specify: Type ULF AM33 AQUAMIST Nozzle with 57°C (135°F) temperature rating, finish (specify), and P/N (specify):

Natural Brass	49-033-1-135
Pure White (RAL9010) ^a	49-033-3-135
Signal White (RAL9003) ^b	49-033-4-135
Chrome Plated	49-033-9-135

a. Eastern Hemisphere sales only
b. Formerly known as Bright White

Escutcheon

Specify: Style 20 Recessed Escutcheon with (specify*) finish, P/N (specify*)

* Refer to Technical Data Sheet TFP770

Wrench

Specify: W-Type 6 Sprinkler Wrench, P/N 56-000-6-387

Specify: W-Type 7 Sprinkler Wrench, P/N 56-850-4-001