

## Stored Pressure Extinguisher Brackets

### Description

Brackets are available for each SENTRY and CLEANGUARD hand portable extinguisher. Certain applications require extinguishers to be mounted in brackets for safety and restraint.

### Installation and Mounting

Make certain mounting location and position meet NFPA-10 requirements.

Brackets may be mounted in a vertical, horizontal or sloping position on sufficiently strong, stationary supporting surfaces or within suitable vehicle compartments.

The brackets are provided with mounting holes in the back plate (frame) and/or mounting holes in the base. The mounting surface will usually dictate that either the back or the base

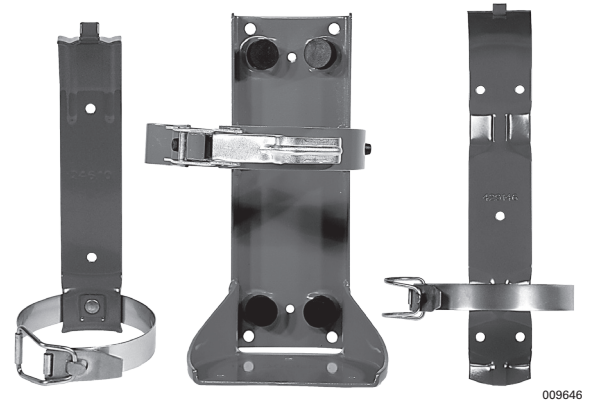

of the bracket be used but in some cases, both may be used to improve the weight distribution. Use good quality fasteners, one in each mounting hole. Fasteners should be tightened as recommended for the specific type and grade of fastener used.

Even though welding is an effective method of securing the bracket in place, it is NOT recommended because Johnson Controls has no control over the placement and quality of the welds.

### Models

#### Part No. 24610

- SY-0216
- SY-0236
- SY-0241
- SY-0243
- A02
- A02VB
- A02S
- A02SVB
- C02VB
- FE02VB

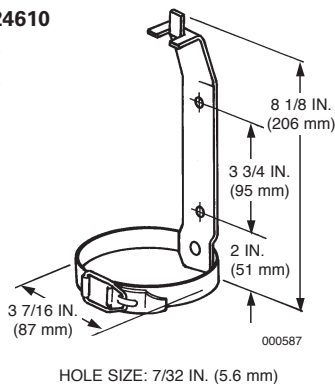

#### Part No. 429146

- A05
- A05S
- A05VB
- A05SVB
- AA05
- AA05VB
- AA05S-1
- AA05S-1VB
- PK05
- PK05S
- C05
- FE05
- FE05S

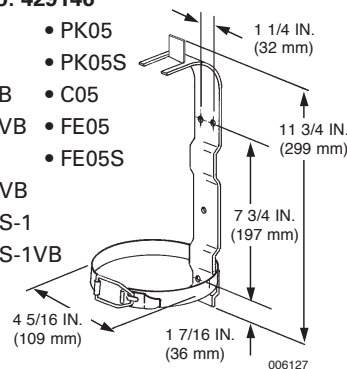

#### Part No. 30865

- SY-1013
- SY-1014
- SY-1023
- SY-1024
- SY-1033
- SY-1034
- SY-1441
- A10H
- A10I
- PK10
- PK10I
- C10
- C10I

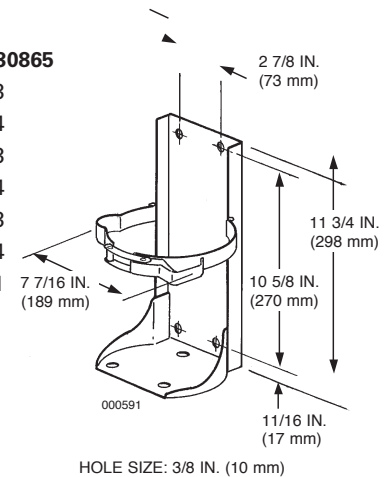

#### Part No. 415824

- SY-0516
- SY-0517
- SY-0521
- SY-0531

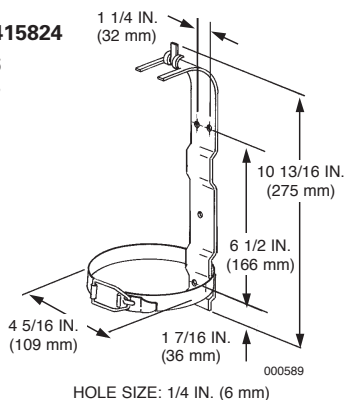

#### Part No. 435793

- AA10S
- PK10S
- C10S
- HF-AA10S
- HF-PK10S
- AA10SI
- PK10SI
- HF-AA10SI
- HF-PK10SI

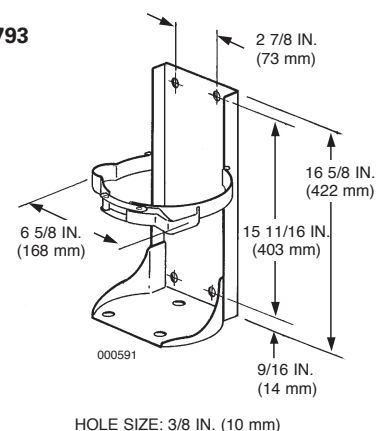

## Models (Continued)

### Part No. 79456

- SY-1071
- SY-1072
- SY-1571
- SY-1572
- CD10
- CD15
- CD10A
- CD15A
- CD10-1
- CD15-1
- CD10-2
- CD15-2

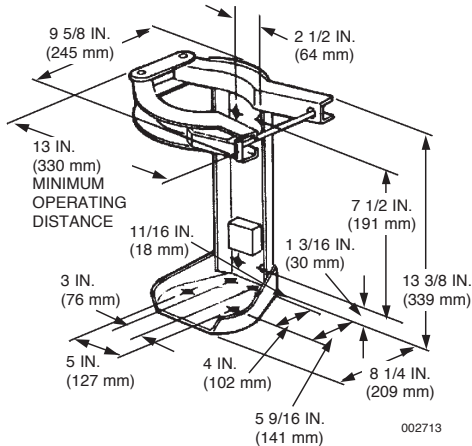

### Part No. 30937

- SY-2013
- SY-2014
- SY-2023
- SY-2024
- CA-1481
- AA20
- A20I
- AA20-1
- AA20I-1
- HF-AA20-1
- HF-PK20
- HF-AA20I-1
- HF-PK20I
- PK20
- PK20I
- C20
- C20I
- FE13
- SY-2033
- SY-2034
- SY-1741

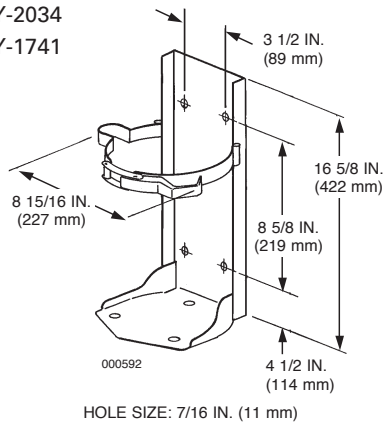

### Part No. 25419

- SY-0571
- SY-0572
- CD05
- CD05A

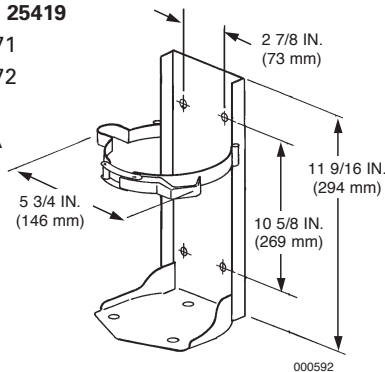

### Part No. 422737

- CA-1081
- FE09

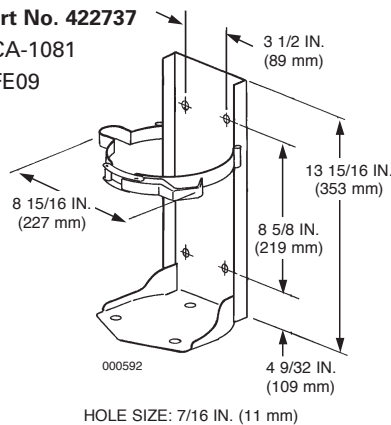

### Part No. 417898

- A10T
- SY-1015

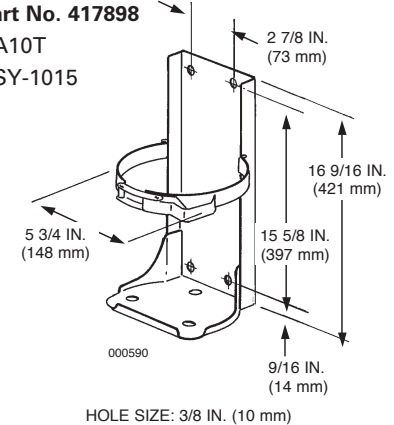

## Mounting Location

Two considerations will affect the choice of bracket mounting location.

The first is fire protection needs.

1. The extinguisher must be visible, not hidden in an out-of-the-way spot.
2. The extinguisher must be easy to reach.
3. The extinguisher should not be placed where a fire is likely to make it inaccessible.

The second set of considerations deal with keeping the extinguisher safe and secure.

1. Avoid locations where grease or oil could build up on the extinguisher and bracket.
2. Select a relatively flat mounting surface which is strong enough to support the weight of the extinguisher and bracket.
3. Avoid surfaces which may flex enough to cause metal fatigue in the bracket support.
4. Be sure there is enough space to allow proper mounting of the bracket and easy access to the extinguisher.
5. Avoid locations that may expose the extinguisher to temperatures detrimental to its operation (such as too near a motor or exhaust manifold).

### Part No. 25420

- SY-2071
- SY-2072
- CD20
- CD20A
- CD20-1
- CD20-2

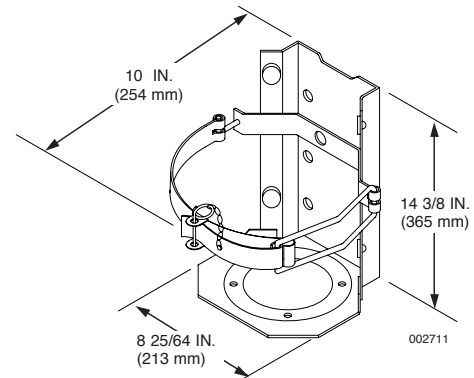

**Note:** The converted metric values in this document are provided for dimensional reference only and do not reflect an actual measurement.

SENTRY, CLEANGUARD and the product names listed in this material are marks and/or registered marks. Unauthorized use is strictly prohibited.