

Model S-150-C and Model S-350-C Stationary Fire Extinguishers

Application

ANSUL® Stationary Fire Extinguishers are manufactured to provide protection for hazardous areas where the potential for large fire exists. The extinguishers can be strategically located to provide maximum protection for a wide variety of hazards, including hazards in confined spaces, and require one trained person for operation.

All units are available with either FORAY or Purple K dry chemical. Each extinguisher can be floor-mounted to protect specific hazards, or truck-mounted for added mobility.

This stationary extinguisher is completely self-contained. An attached nitrogen cylinder is the only pressure source required to completely expel the fire suppressing agent. The pressure remaining in the tank after operation is sufficient for cleaning dry chemical from the discharge hose.

Typical Applications

150 lb units:

- Paint spray booths
- Dip and quench tanks
- Warehouse storage racks
- Electrical switch gears

350 lb units:

- Offshore platforms
- Loading racks
- Fuel storage areas
- Heavy manufacturing operations

Description

ANSUL S-150 and S-350-C Stationary Fire Extinguishers offer these features:

- Features a corrosion-resistant package.
- Listed by Underwriters Laboratories.
- Pressurized by turning the nitrogen cylinder hand valve. An optional Quick-Opening valve is also available.
- Includes discharge nozzle with two-position ball valve for simple operation, and aluminum barrel which produces a solid, round agent stream. Available with optional long range nozzle for increased range and flow-rate; especially effective for gas and liquid pressure fires, and gravity fires as well as fires with obstacles.
- Includes a fill cap pressure indicator to determine at a glance if the extinguisher has been pressurized.
- Simple hose clean-out procedure saves time and chemical.

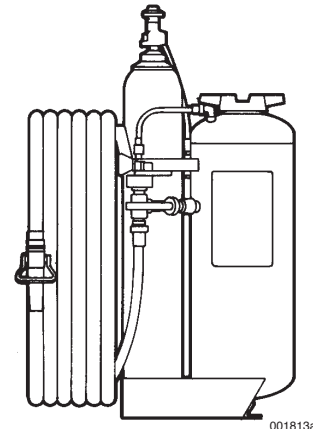

Specifications

Agent Tank – The extinguisher tank is of welded steel construction with two elliptical dished heads and welded circumferential seams. The tank shall be designed and constructed for a working pressure of 250 psi (17.2 bar). The top of the tank is fitted with a 4 in (102 mm) ID (Inside Diameter) fill opening. The tank head shall have a brass bodied safety relief with bursting disc which will vent at approximately 425 psi (29.3 bar).

Nitrogen Cylinder and Valve – The nitrogen cylinder is mounted in a vertical position. Such mounting permits easy access to the cylinder. This cylinder shall be a 110 ft³ (3.1 m³) for the 150 lb units, and 220 ft³ (6.2 m³) for the 350 lb units, Medical "E" nitrogen cylinder.

Each cylinder is equipped with a conventional hand wheel nitrogen cylinder valve and visual pressure gauge. A quick-opening valve is available as an option. Both valves are UL listed.

Hoses and Nozzles – The discharge hose is UL Listed, equipped with chrome plated brass couplings and 3/4 in (19 mm) to 1 in (25 mm) ID. It utilizes a pin prick outside cover to permit diffusion of gases.

The nozzle consists of a two-position ball valve and barrel. The nozzle barrel is a three-hole cone tip. The nozzle ball valve assembly is chrome-plated brass.

Two ball valve assemblies are provided for discharge hose clean-out procedures. Each ball valve handle requires 1/4 turn for valve operation.

Nameplates – The nameplate is glare-resistant etched aluminum, which contains hazard identification plus operating and maintenance instructions.

Finish – In addition to the standard surface preparation procedures, the steel parts are primed using a zinc rich primer with a minimum zinc content of 90%. The top coat is an epoxy paint applied as a liquid and oven or air cured. The dry film is continuous and a minimum thickness of 5-7 mills. The fill cap and nozzle body is chrome plated for added corrosion-resistance.

*Optional 100 ft (30.5 m) hose available.

S-150-C Lb Unit Specifications

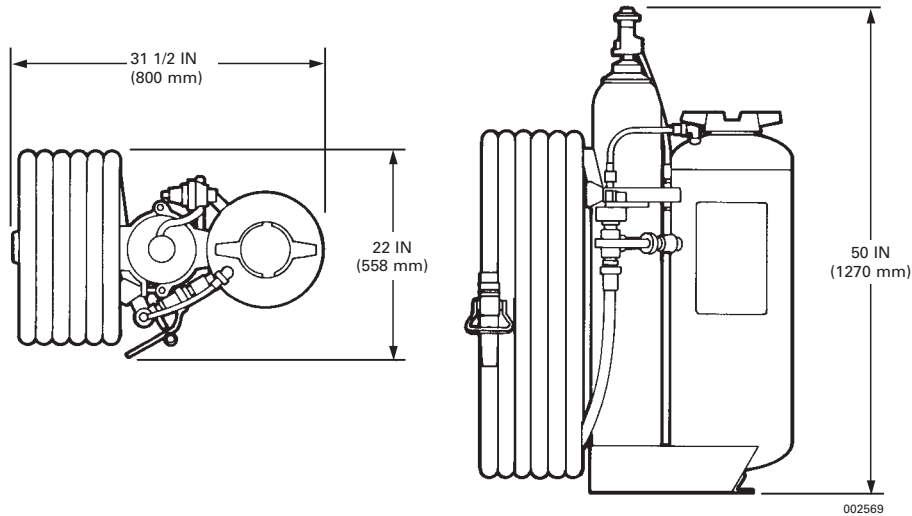

Part No.	Model No.	Agent	Finish	Hose		Nozzle	Shipping Weight		Nozzle Flow Rate*		Approximate Range		Effective Discharge Time** (sec)
				ft	(m)		Uncharged lbs	(kg)	lbs/sec	(kg/sec)	ft	(m)	
30199	S-CR-A-150-C	FORAY	Epoxy	3/4 in. x	50 (15.24)	16	451	(204)	3.4	(1.54)	25 (7.62)	35	
30195	S-CR-K-150-C	Purple-K	Epoxy	3/4 in. x	50 (15.24)	16	451	(204)	3.4	(1.54)	25 (7.62)	37	
30196	S-CR-LR-K-150-C	Purple-K	Epoxy	3/4 in. x	50 (15.24)	LR-36	451	(204)	4.4	(1.99)	35 (7.62)	32	

S-350-C Lb Unit Specifications

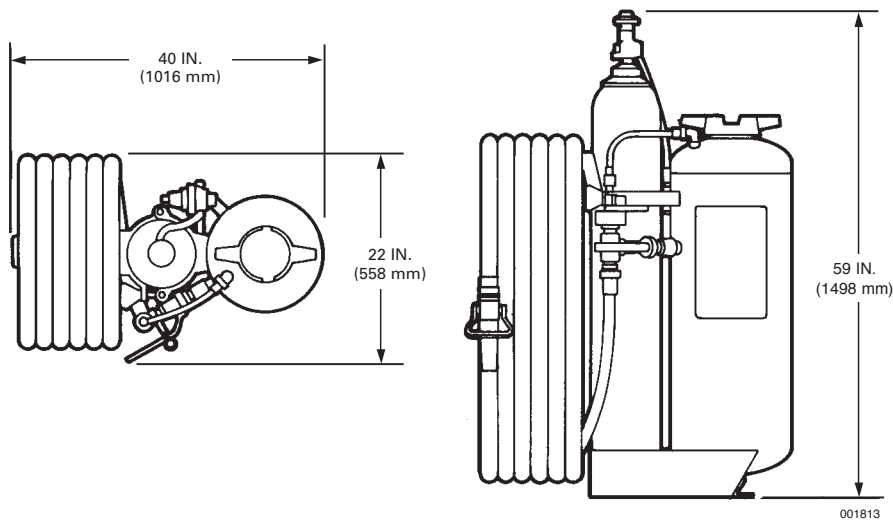

Part No.	Model No.	Agent	Finish	Hose		Nozzle	Shipping Weight		Nozzle Flow Rate*		Approximate Range		Effective Discharge Time** (sec)
				ft	(m)		Uncharged lbs	(kg)	lbs/sec	(kg/sec)	ft	(m)	
30209	S-CR-A-350-C	FORAY	Epoxy	1 in. x	50 (15.24)	25	894	(405)	7.2	(3.26)	30 (9.14)	45	
31124	S-CR-LR-K-350-C	Purple-K	Epoxy	1 in. x	100 (30.48)	LR-44	928	(420)	6.8	(3.08)	40 (12.19)	49	
30205	S-CR-K-350-C	Purple-K	Epoxy	1 in. x	50 (15.24)	24	894	(405)	7.0	(3.17)	30 (9.14)	52	

*All flow rates are average with a 10% tolerance used by UL

**Effective times are a visual determination of gas point and are approximate