

## Remote Hose Reel Assemblies with Manual Rewind

### Application

In many cases an ANSUL® fire suppression system has to be located at a distance from the fire hazard area. Because every second counts when responding to a fire, Johnson Controls offers remote hose reels for placement near hazard areas that are located away from the main fire suppression system.

### Description

ANSUL remote hose reels are designed to send dry chemical from the main system directly to the hazard area. This is accomplished by means of a remote pneumatic actuator (not included) mounted on the hose reel assembly. By pulling the ring pin and pushing the lever on the actuator, the operator can send dry chemical directly to the nozzle that must be used to suppress the fire.

Several hose reels can be used from a single ANSUL dry chemical system.

### Options

#### Weather Cover

This weather cover will shield remote hose reel assemblies from rain, sun, snow, etc. The 8 oz (226.8 g) PVC material is reinforced with a rip-resistant polyester cord and will stand up in temperatures ranging from -40 °F to 170 °F (-40 °C to 77 °C). The cover is mildew-proof and oil-resistant. One weather cover fits all remote hose reel assemblies and can be ordered under Part No. 51061.

#### Electric Rewind

Electric rewind is available for new hose reel assemblies only. Electric rewind kits are installed at the factory. The explosion-proof motor is run off a 12/24 VDC power source and is activated by a push-button switch. For ordering information, contact Johnson Controls.

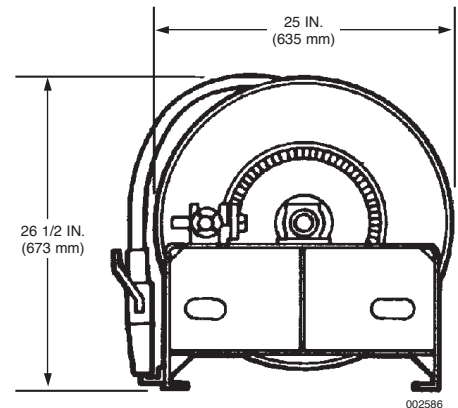
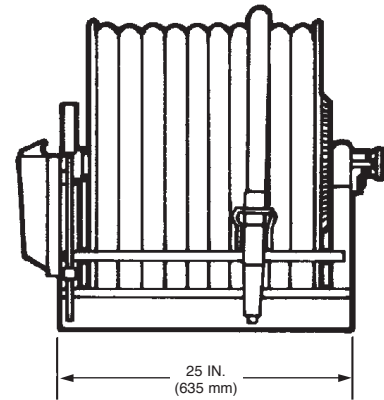

### Ordering Information

Part No.	Finish	Standard Hose	Nozzle	Approximate Shipping Weight
74772	Epoxy	1 in. x 150 ft (25 mm x 45.7 m)	HF-70	334 lb (151.5 kg)
74776	Epoxy	1 in. x 150 ft (25 mm x 45.7 m)	LR-44	334 lb (151.5 kg)
74764	Epoxy	1 in. x 100 ft (25 mm x 30.5 m)	HF-70	256 lb (116.1 kg)
74768	Epoxy	1 in. x 100 ft (25 mm x 30.5 m)	LR-44	256 lb (116.1 kg)
74740	Epoxy	3/4 in. x 150 ft (19 mm x 45.7 m)	HF-35	250 lb (113.4 kg)
74744	Epoxy	3/4 in. x 150 ft (19 mm x 45.7 m)	LR-36	250 lb (113.4 kg)
74732	Epoxy	3/4 in. x 100 ft (19 mm x 30.5 m)	HF-35	220 lb (99.8 kg)
74736	Epoxy	3/4 in. x 100 ft (19 mm x 30.5 m)	LR-36	220 lb (99.8 kg)

## Ordering Information (Continued)

Part No.	Finish	Low Temperature Hose	Nozzle	Approximate Shipping Weight
74788	Epoxy	LT-1 in. x 150 ft (25 mm x 45 m)	HF-70	334 lb (151.5 kg)
74792	Epoxy	LT-1 in. x 150 ft (25 mm x 45 m)	LR-44	334 lb (151.5 kg)
74780	Epoxy	LT-1 in. x 100 ft (25 mm x 30 m)	HF-70	256 lb (116.1 kg)
74784	Epoxy	LT-1 in. x 100 ft (25 mm x 30 m)	LR-44	256 lb (116.1 kg)
74756	Epoxy	LT-3/4 in. x 150 ft (19 mm x 45 m)	HF-35	250 lb (113.4 kg)
74760	Epoxy	LT-3/4 in. x 150 ft (19 mm x 45 m)	LR-36	250 lb (113.4 kg)
74748	Epoxy	LT-3/4 in. x 100 ft (19 mm x 30 m)	HF-35	220 lb (99.8 kg)
74752	Epoxy	LT-3/4 in. x 100 ft (19 mm x 30 m)	LR-36	220 lb (99.8 kg)

**Note:** The converted metric values in this document are provided for dimensional reference only and do not reflect an actual measurement.

ANSUL, and the product names listed in this material are marks and/or registered marks. Unauthorized use is strictly prohibited.