



AD1305

CORNER MOUNT HOUSING



FEATURES

- Corner-mounted
- Heavy-gauge steel construction
- Tamper resistant
- Distortion-free Lexan® viewing window
- 203 mm (8 in) maximum camera length
- Perfect for use in elevators
- Easy to install

The AD1305 is an attractive, tamper resistant corner-mounted housing. Primarily designed for use in elevators, this compact unit is also perfect for stairwells, entrances, hallways, small offices, jail holding rooms, etc.

Construction is of heavy gauge steel throughout with a 6.35 mm (0.25 in) thick replaceable Lexan window. All mounting bolts and cable entries are protected. The housing is secured from unauthorized entries by the use of two tamper resistant security screws.

The housing permits maximum viewing coverage in confined areas for most low-profile cameras using wide angle lenses. The exposed surface of the unit has a beige baked enamel finish.

SPECIFICATIONS

Model Number

AD1305 Camera housing, indoor, corner-mount

Mechanical

Dimensions (H x W x D) 238.1 x 242.9 x 241.3 mm
(9.37 x 9.6 x 9.5 in)

Construction

Housing 14 gauge (1.9 mm) steel
 Viewing Window 6.35 mm (0.25 in) thick Lexan
 Finish Baked enamel texture
 Color Beige
 Weight 4.13 kg (9.1 lbs)
 Shipping Weight 4.83 kg (10.66 lbs)
 Cable Entry Through back opening
 Locking Two tamper resistant button head security screws
 Maximum Camera/
 Lens Size 203 mm (8.0 in)
 Camera Mounting Brackets with adjustable slots allow for front to back and vertical camera movement

INDOOR INSTALLATION ONLY

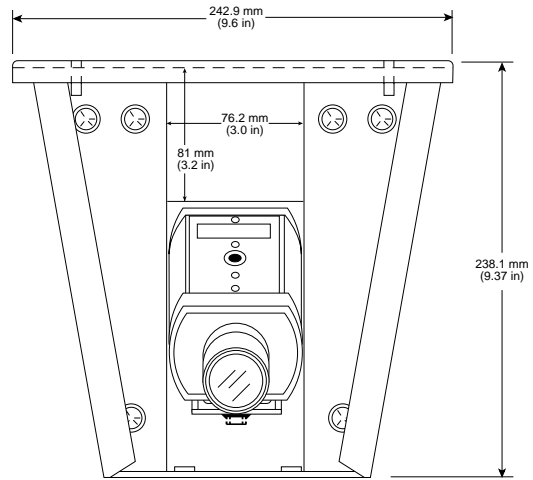

Front View (No Cover)

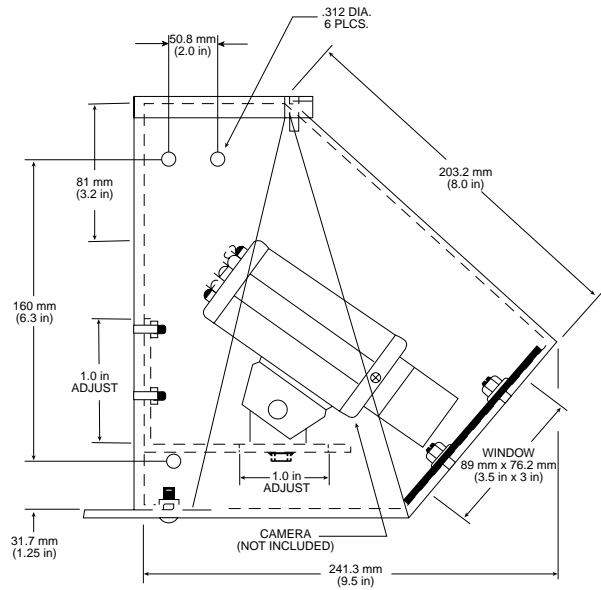

Side View (With Cover)