



AD1314

ENVIRONMENTAL CAMERA HOUSING



FEATURES

- Indoor/outdoor housing
- Housing length accommodates most cameras and zoom lenses
- Cover opens 180° for easy camera access
- Tough, high-impact polymer construction
- IP4/NEMA-3R protection
- Automatic regulating heater available
- 24 VAC blower, optional
- 24 VAC heater, optional
- Tamper resistant
- Electrically isolated camera platform
- Multiple cable pass mounts available

The AD1314 is a high quality environmental housing designed for most CCD cameras and zoom lenses. This polycarbonate housing provides excellent protection for the installed camera. The unique 180° opening of the cover provides full and easy access to the camera and lens for trouble-free installation and servicing.

The camera platform can be securely attached in any position along the full length of the housing. This platform is constructed of a rigid non-conductive material which helps to eliminate common grounding problems.

In cold weather climates, or where condensation problems exist, the optional blower and low current heater automatically regulates its output to provide heat in the housing and maintain a clear viewing window.

AMERICAN DYNAMICS ENVIRONMENTAL CAMERA HOUSING

SPECIFICATIONS

Model Numbers

AD1314	Environmental Camera Housing
AD1314-HB24*	Environmental Camera Housing 24 VAC heater and blower installed
RTHOUTDR*	Environmental Camera Housing with wall mount and 24 VAC heater and blower installed

* This housing must be powered by a Class II source. This housing is to be used with a camera that meets Class II requirements.

Mechanical

Construction

Housing	Magnum® 941 Polymer
Viewing Window	4.8 mm (0.19 in) Lexan®
Color	Light gray
Finish	Epoxy
Dimensions (H x W x D)	141 x 158 x 449 mm (5.56 x 6.2 x 17.68 in)

Unit Weight

Without Sunshield	1.8 kg (4.0 lbs)
Shipping Weight	2.4 kg (3.3 lbs)
With Sunshield	3.2 kg (7.0 lbs)
Shipping Weight	3.8 kg (8.4 lbs)

Cable EntryVia cable pass mount

Maximum Camera/
Lens Length304.8 mm (12 in)

Heater

Type	Thermostatically controlled pad heater
Supply Voltage	24 VAC
Power	0.63 A
Weight68 g (0.15 lbs)

Environmental

Weatherproof Standard	IP4 (NEMA-3R)
Operating Temperature	-23° to 43° C (-10° to 110° F) with heater and blower 85% (non-condensing)

Accessories

AD1314-SS	Sunshield
AD1314-H24	24 VAC heater
AD1314-B24	24 VAC blower

Recommended Housing Mounts

ADCHMTCEIL	Ceiling mount 9.6 kg (20 lbs) capacity
ADCHMTWALL	Wall mount 9.6 kg (20 lbs) capacity
ADCHMTPOLE	Pole mount 9.6 kg (20 lbs) capacity
ADCHMTCRNR	Corner mount 9.6 kg (20 lbs) capacity
ADCHMTPED	Pedestal mount 9.6 kg (20 lbs) capacity

Regulatory

SafetyUL2044



Housing with Sunshield



Housing in open position

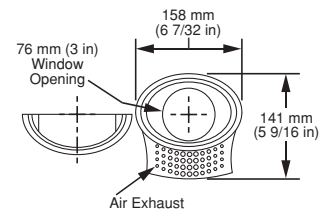
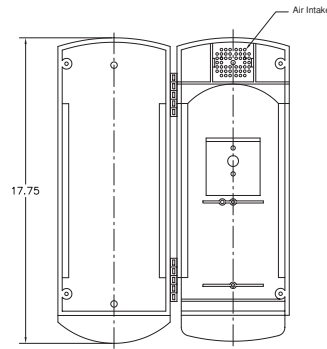

Housing

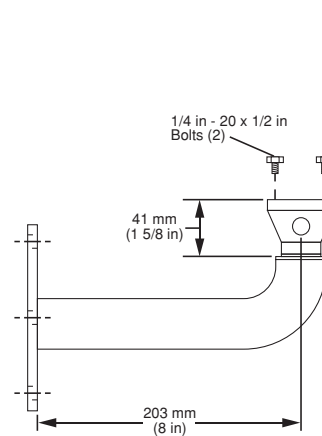

Wall Mount Side View
ADCHMTWALL

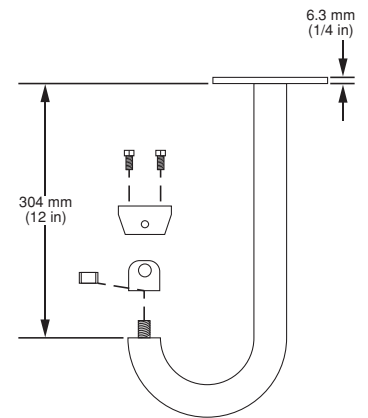

Ceiling Mount Side View
ADCHMTCEIL

Mounts

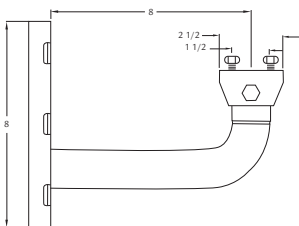

Pole Mount Side View
ADCHMTPOLE

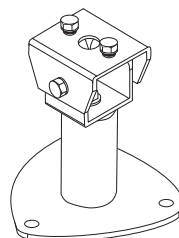

Pedestal Mount Side View
ADCHMTPED

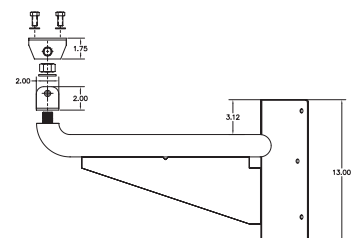

Corner Mount Side View
ADCHMTCRNR